



# NCERT EXEMPLAR

Problems-Solutions

# Chemistry

Class XII

Detailed Explanation to all  
Objective & Subjective Problems



A Highly Useful **Question-Solution Bank**  
for **School/Board** and **Engineering & Medical Entrances**

NCERT  
**EXEMPLAR**

Problems-Solutions

**Chemistry**

**Class XII**

**Detailed Explanations to all  
Objective & Subjective Problems**



# NCERT **EXEMPLAR**

Problems-Solutions

# Chemistry

## Class XII

**Detailed Explanations to all  
Objective & Subjective Problems**

*Ramashish Paul*



**ARIHANT PRAKASHAN**



*(School Division Series)*



# ARIHANT PRAKASHAN

(School Division Series)

All Rights Reserved

---

## 卐 © PUBLISHERS

No part of this publication may be re-produced, stored in a retrieval system or distributed in any form or by any means, electronic, mechanical, photocopying, recording, scanning, web or otherwise without the written permission of the publisher. Arihant has obtained all the information in this book from the sources believed to be reliable and true. However, Arihant or its editors or authors or illustrators don't take any responsibility for the absolute accuracy of any information published and the damages or loss suffered there upon.

All disputes subject to Meerut (UP) jurisdiction only.

## 卐 ADMINISTRATIVE & PRODUCTION OFFICES

### **Regd. Office**

'Ramchhaya' 4577/15, Agarwal Road, Darya Ganj, New Delhi -110002  
Tele: 011- 47630600, 43518550; Fax: 011- 23280316

### **Head Office**

Kalindi, TP Nagar, Meerut (UP) - 250002  
Tele: 0121-2401479, 2512970, 4004199; Fax: 0121-2401648

## 卐 SALES & SUPPORT OFFICES

Agra, Ahmedabad, Bengaluru, Bareilly, Chennai, Delhi, Guwahati,  
Hyderabad, Jaipur, Jhansi, Kolkata, Lucknow, Meerut, Nagpur & Pune

卐 ISBN : 978-93-5176-464-9

卐

Published by Arihant Publications (India) Ltd.

For further information about the books published by Arihant  
log on to [www.arihantbooks.com](http://www.arihantbooks.com) or email to [info@arihantbooks.com](mailto:info@arihantbooks.com)

 /arihantpub

 /@arihantpub

 Arihant Publications

 /arihantpub

# PREFACE

The Department of Education in Science & Mathematics (DESM) & National Council of Educational Research & Training (NCERT) developed **Exemplar Problems** in Science and Mathematics for Secondary and Senior Secondary Classes with the objective to provide the students a large number of quality problems in various forms and format *viz.* Multiple Choice Questions, Short Answer Questions, Long Answer Questions etc., with varying levels of difficulty.

NCERT Exemplar Problems are very important for both; School & Board Examinations as well as competitive examinations like Engineering & Medical Entrances. The questions given in exemplar book are mainly of higher difficulty order by practicing these problems, you will be able to manage with the margin between a good score and a very good or an excellent score.

Approx 20% problems asked in any Board Examination or Entrance Examinations are of higher difficulty order, exemplar problems will make you ready to solve these difficult problems.

This book **NCERT Exemplar Problems-Solutions Chemistry XII** contains Explanatory & Accurate Solutions to all the questions given in NCERT Exemplar Chemistry book.

For the overall benefit of the students' we have made unique this book in such a way that it presents not only hints and solutions but also detailed and authentic explanations. Through these detailed explanations, students can learn the concepts which will enhance their thinking and learning abilities.

We have introduced some additional features with the solutions which are as follows

- **Thinking Process** Along with the solutions to questions we have given a thinking process that tells how to approach to solve a problem. Here, we have tried to cover all the loopholes which may lead to confusion. All formulae and hints are discussed in detail.
- **Note** We have provided notes also to solutions in which special points are mentioned which are of great value for the students.

For the completion of this book, I would like to thank Priyanshi Garg who helped me at project management level.

*With the hope that this book will be of great help to the students,  
I wish great success to my readers.*

Author

# CONTENTS

1. Solid State	1-25
2. Solution	26-45
3. Electrochemistry	46-67
4. Chemical Kinetics	68-92
5. Surface Chemistry	93-112
6. General Principles and Processes of Isolation of Elements	113-128
7. The <i>p</i> -Block Elements	129-152
8. The <i>d</i> - and <i>f</i> -Block Elements	153-172
9. Coordination Compounds	173-196
10. Haloalkanes and Haloarenes	197-234
11. Alcohols, Phenols and Ethers	235-264
12. Aldehydes, Ketones and Carboxylic Acids	265-287
13. Amines	288-318
14. Biomolecules	319-346
15. Polymers	347-366
16. Chemistry in Everyday Life	367-398

# 1

## Solid State

### Multiple Choice Questions (MCQs)

**Q. 1** Which of the following conditions favours the existence of a substance in the solid state?

- (a) High temperature (b) Low temperature  
(c) High thermal energy (d) Weak cohesive forces

**Ans. (b)** At low temperature existence of a substance in solid state is due to

- (a) slow molecular motion and  
(b) strong cohesive forces

These two forces hold the constituent particles together thus causes existence of substance in solid state.

**Q. 2** Which of the following is not a characteristic of a crystalline solid?

- (a) Definite and characteristic heat of fusion  
(b) Isotropic nature  
(c) A regular periodically repeated pattern of arrangement of constituent particles in the entire crystal  
(d) A true solid

**Ans. (b)** Crystalline solid is anisotropic in nature as this solid shows different physical properties such as electrical resistance, refractive index in different directions.

**Note** Isotropic and anisotropic properties are related to amorphous solid and crystalline solid which can be clearly understood as

Property	Types of solid	Physical properties
Isotropy	Amorphous solid	Same value
Anisotropy	Crystalline solid	Different values

**Q. 3** Which of the following is an amorphous solid?





- (a) Graphite (C) (b) Quartz glass ( $\text{SiO}_2$ )  
(c) Chrome alum (d) Silicon carbide ( $\text{SiC}$ )

**Ans. (b)** Quartz glass ( $\text{SiO}_2$ ) is an amorphous solid due to its short range order of constituent particles.

**Note** Quartz is a crystalline solid while quartz glass is an amorphous solid.



**Q. 4** Which of the following arrangements shows schematic alignment of magnetic moments of antiferromagnetic substances?

- (a)  (b) 
- (c)  (d) 

**Ans. (d)** The substances which have domain structure are oppositely oriented and cancel each other's magnetic field are known as antiferromagnetic substances.



**Schematic arrangement of antiferromagnetic substance**

**Q. 5** Which of the following is true about the value of refractive index of quartz glass?

- (a) Same in all directions (b) Different in different directions  
(c) Cannot be measured (d) Always zero

**Ans. (a)** Since, quartz glass is an amorphous solid having short range order of constituents. Hence, value of refractive index is same in all directions, can be measured and not be equal to zero always.

**Q. 6** Which of the following statement is not true about amorphous solids?

- (a) On heating they may become crystalline at certain temperature  
(b) They may become crystalline on keeping for long time  
(c) Amorphous solids can be moulded by heating  
(d) They are anisotropic in nature

**Ans. (d)** Amorphous solids are isotropic in nature because it has no long range order and any physical property will be same on all direction. On the other hand, anisotropic nature is a characteristic feature of crystalline solid.

**Q. 7** The sharp melting point of crystalline solids is due to .....

- (a) a regular arrangement of constituent particles observed over a short distance in the crystal lattice  
(b) a regular arrangement of constituent particles observed over a long distance in the crystal lattice  
(c) same arrangement of constituent particles in different directions  
(d) different arrangement of constituent particles in different directions

**Ans. (b)** Crystalline solid has regular arrangement of constituent particles observed over a long distance in the crystal lattice. Due to this regular arrangement crystalline solid have sharp melting point.

**Q. 8** Iodine molecules are held in the crystals lattice by .....

- (a) London forces (b) dipole-dipole interactions  
(c) covalent bonds (d) coulombic forces

**Ans. (a)** Iodine molecules are a class of non-polar molecular solid in which constituents molecules are held together by London or dispersion forces. These solids are soft and non-conductor of electricity.

**Q. 9** Which of the following is a network solid?

- (a)  $\text{SO}_2$  (solid) (b)  $\text{I}_2$   
(c) Diamond (d)  $\text{H}_2\text{O}$  (ice)

**Ans. (c)** Diamond is a giant molecule in which constituent atoms are held together by covalent bond. Hence, this is a network solid.

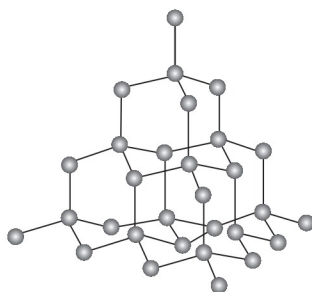

**Network structure of atom**

**Q. 10** Which of the following solids is not an electrical conductor?

1.  $\text{Mg}(s)$  2.  $\text{TiO}(s)$  3.  $\text{I}_2(s)$  4.  $\text{H}_2\text{O}(s)$   
(a) Only 1 (b) Only 2 (c) 3 and 4 (d) 2, 3 and 4

**Ans. (c)** Iodine is a non-polar molecular solid in which iodine molecules are held together by London force or dispersion force. This is soft and non-conductor of electricity. Water is a hydrogen bonded molecular solid in which H and O are held together by polar covalent bond and each water molecule held together by hydrogen bonding. Due to non-ionic nature, they are not electrical conductor.

**Q. 11** Which of the following is not the characteristic of ionic solids?

- (a) Very low value of electrical conductivity in the molten state  
(b) Brittle nature  
(c) Very strong forces of interactions  
(d) Anisotropic nature

**Ans. (a)** Ionic solids easily dissociated into its ions in molten state and show high electrical conductivity. So, statement (a) is incorrect while ionic solids are anisotropic and brittle linked with very strong force of interactions.

**Q. 12** Graphite is a good conductor of electricity due to the presence of .....

- (a) lone pair of electrons (b) free valence electrons  
(c) cations (d) anions

**Ans. (b)** Graphite is a good conductor of electricity due to presence of free valence electrons. In graphite, each carbon is  $sp^2$  hybridised having one free electron which makes graphite a good conductor of electricity.

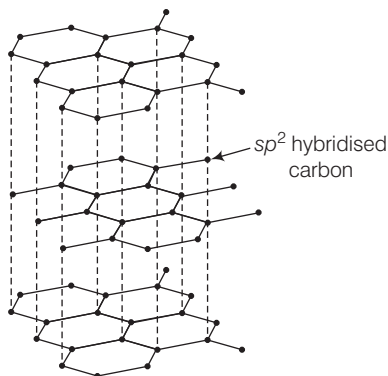

**Q. 13** Which of the following oxides behaves as conductor or insulator depending upon temperature?

- (a) TiO                      (b)  $SiO_2$                       (c)  $TiO_3$                       (d) MgO

**Ans. (c)** Certain metal oxides like  $VO_2$ , VO,  $VO_3$  and  $TiO_3$  show metallic or insulating property depending upon temperature. As temperature varies metallic or insulating property varies. This is due to variation in energy gap between conduction band and valence band.

**Q. 14** Which of the following oxides shows electrical properties like metals?

- (a)  $SiO_2$                       (b) MgO                      (c)  $SO_2(s)$                       (d)  $CrO_2$

**Ans. (d)**  $CrO_2$ , TiO and  $ReO_3$  are some typical metal oxides which show electrical conductivity similar to metal. While  $SiO_2$ , MgO and  $SO_2$  are oxides of metal, semimetal and non-metal which do not show electrical properties.

**Q. 15** The lattice site in a pure crystal cannot be occupied by .....

- (a) molecule                      (b) ion                      (c) electron                      (d) atom

**Ans. (c)** Each point in a lattice is known as lattice point which are either atom or molecule or ion which are joined together by a straight line to bring out geometry of lattice in pure crystal constituents are arranged in fixed stoichiometric ratio.

Hence, existence of free electrons are not possible, it is possible on in case of imperfection in solid.

**Q. 16** Graphite cannot be classified as .....

- (a) conducting solid                      (b) network solid  
(c) covalent solid                      (d) ionic solid

**Ans. (d)** Graphite can't be classified as ionic solid as graphite is not made up of ions. It is made up of carbon atoms covalently bonded to three carbon atoms so, it is a covalent solid.

Since, the formation of covalent bond occurs throughout the crystal therefore, it is a type of network solid. Due to presence of free electron graphite is also classified as conductor solid.

**Q. 17** Cations are present in the interstitial sites in .....

- (a) Frenkel defect
- (b) Schottky defect
- (c) vacancy defect
- (d) metal deficiency defect

**Ans. (a)** When smaller ion (usually cation) is dislocated from its normal site in crystal and move to interstitial site is known as Frenkel defect as shown below

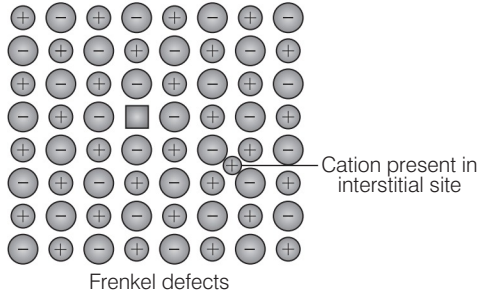

**Q. 18** Schottky defect is observed in crystals when .....

- (a) some cations move from their lattice site to interstitial sites
- (b) equal number of cations and anions are missing from the lattice
- (c) some lattice sites are occupied by electrons
- (d) some impurity is present in the lattice

**Ans. (b)** Schottky defect is observed in crystal when equal number of cations and anions are missing from the lattice. Thus, density of solid decreases.

When some cations move from their lattice site to interstitial site is known as Frenkel defect. When some impurity is present on crystal is known as impurity defect.

When lattice site is occupied by electron, this type of defect is known as metal excess defect. Hence, except (b) all statements are incorrect regarding Schottky defect.

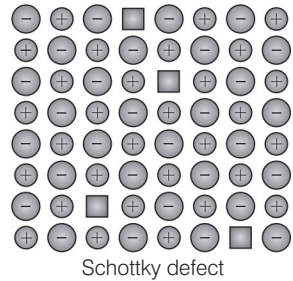

**Q. 19** Which of the following is true about the charge acquired by p - type semiconductors?

- (a) Positive
- (b) Neutral
- (c) Negative
- (d) Depends on concentration of *p* impurity

**Ans. (b)** When group 13 elements are doped in group 14 element, it creates a hole in a molecule but the molecule as a whole remain neutral. Thus, *p*-type semiconductor is neutral in nature.

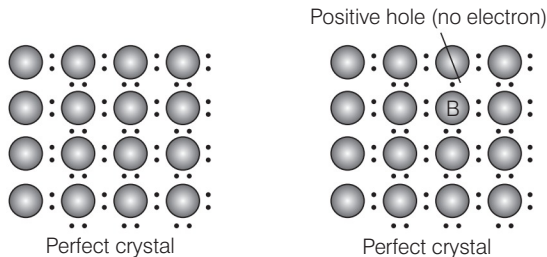

**Q. 20** To get a *n*-type semiconductor from silicon, it should be doped with a substance with valency .....

- (a) 2                      (b) 1                      (c) 3                      (d) 5

**Ans. (d)** To get a *n*-type semiconductor from silicon, it should be doped with a substance with valence 5.

e.g., Si doped with P lead to formation of *n*-type semiconductor as shown below

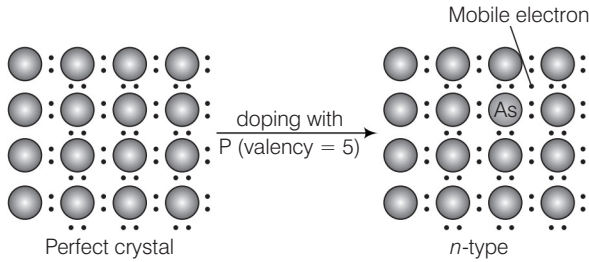

**Q. 21** The total number of tetrahedral voids in the face centred unit cell is

.....

- (a) 6                      (b) 8                      (c) 10                      (d) 12

**💡 Thinking Process**

If number of atoms in fcc unit cell =  $N$

Number of tetrahedral voids =  $2N$

Number of octahedral voids =  $N$

**Ans. (b)** Fcc unit cell contains 8 tetrahedral voids at centre of each 8 smaller cube of an unit cell as shown below

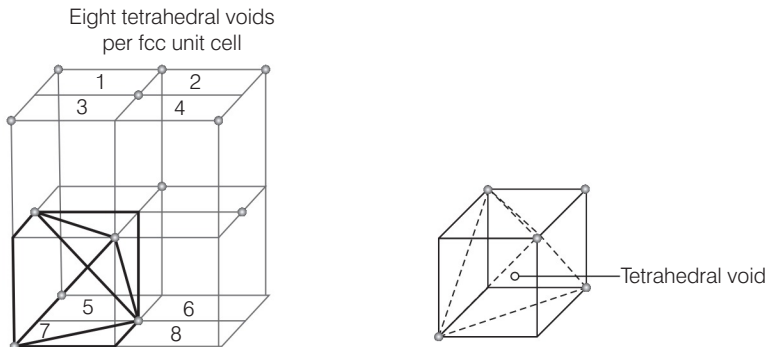

Each cube represented by numeric 1, 2, 3, 4, 5, 6, 7, 8 contain one tetrahedral voids.

Each cube contain one tetrahedral void at its body centre as shown above

Number of atoms in fcc unit cell = 4

Number of octahedral voids = 4

Number of tetrahedral voids = 8

**Q. 22** Which of the following point defects are shown by AgBr(s) crystals?

1. Schottky defect
2. Frenkel defect
3. Metal excess defect
4. Metal deficiency defect

(a) 1 and 2                      (b) 3 and 4                      (c) 1 and 3                      (d) 2 and 4

**Ans. (a)** AgBr shows both Schottky as well as Frenkel defect. In AgBr, both  $\text{Ag}^+$  and  $\text{Br}^-$  ions are absent from the lattice causing Schottky defect. However,  $\text{Ag}^+$  ions are mobile so they have a tendency to move aside the lattice and trapped in interstitial site hence, cause Frenkel defect.

**Q. 23** In which pair most efficient packing is present?

- (a) hcp and bcc                      (b) hcp and ccp  
(c) bcc and ccp                      (d) bcc and simple cubic cell

**Ans. (b)** Packing efficiency is the percentage of total filled space by particles and it can be calculated as packing efficiency

$$= \frac{\text{Volume occupied by four spheres in the unit cell}}{\text{Total volume of unit cell}} \times 100$$

Since, packing efficiency for hcp or ccp is calculated to be 74% which is maximum among all type of crystals.

**Q. 24** The percentage of empty space in a body centred cubic arrangement is

.....

- (a) 74                      (b) 68                      (c) 32                      (d) 26

**Ans. (c)** Packing efficiency for bcc arrangement is 68% which represents total filled space in the unit cell. Hence, empty space in a body centred arrangement is  $100 - 68 = 32\%$ .

**Note** Here, empty space in bcc arrangement is asked therefore empty space in any crystal packing can be calculated as empty space in unit cell =  $100 - \text{packing efficiency}$

**Q. 25** Which of the following statement is not true about the hexagonal close packing?

- (a) The coordination number is 12
- (b) It has 74% packing efficiency
- (c) Tetrahedral voids of the second layer are covered by the spheres of the third layer
- (d) In this arrangement spheres of the fourth layer are exactly aligned with those of the first layer

**Ans. (d)** Hexagonal close packing can be arranging by two layers

A and B one over another which can be diagrammatically represented as

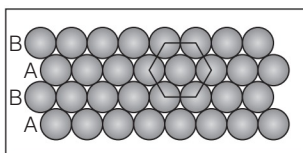

Here, we can see easily that 1st layer and 4th layer are not exactly aligned.

Thus, statement (d) is not correct while other statements (a), (b) and (c) are true.

**Q. 26** In which of the following structures coordination number for cations and anions in the packed structure will be same?

- (a)  $\text{Cl}^-$  ions form fcc lattice and  $\text{Na}^+$  ions occupy all octahedral voids of the unit cell
- (b)  $\text{Ca}^{2+}$  ions form fcc lattice and  $\text{F}^-$  ions occupy all the eight tetrahedral voids of the unit cell
- (c)  $\text{O}^{2-}$  ions form fcc lattice and  $\text{Na}^+$  ions occupy all the eight tetrahedral voids of the unit cell
- (d)  $\text{S}^{2-}$  ions form fcc lattice and  $\text{Zn}^{2+}$  ions go into alternate tetrahedral voids of the unit cell

**Ans. (a)** NaCl crystal have rock salt structure having fcc lattice in which  $\text{Cl}^-$  ions are present at fcc lattice points and face centre and  $\text{Na}^+$  occupies all the octahedral void of given unit cell.

Where, coordination number of  $\text{Na}^+ = 6$   
 coordination number of  $\text{Cl}^- = 6$

**Q. 27** What is the coordination number in a square close packed structure in two dimensions?

- (a) 2
- (b) 3
- (c) 4
- (d) 6

**Ans. (c)** Coordination number in a square closed packed structure in two dimensions is equal to 4 as shown below

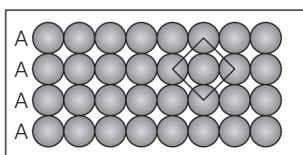

**Cubic closed structure**

**Q. 28** Which kind of defects are introduced by doping?

- (a) Dislocation defect
- (b) Schottky defect
- (c) Frenkel defect
- (d) Electronic defect

**Ans. (d)** When electron rich or electron deficient impurity is added to a perfect crystal it introduces electronic defect in them.

**Q. 29** Silicon doped with electron rich impurity forms .....

- (a) *p*-type semiconductor
- (b) *n*-type semiconductor
- (c) intrinsic semiconductor
- (d) insulator

**Ans. (b)** Silicon doped with electron rich impurity such as phosphorus forms a *n*-type semiconductor. This is due to presence of mobile electron.

**Q. 30** Which of the following statements is not true?

- (a) Paramagnetic substances are weakly attracted by magnetic field
- (b) Ferromagnetic substances cannot be magnetised permanently
- (c) The domains in antiferromagnetic substances are oppositely oriented with respect to each other
- (d) Pairing of electrons cancels their magnetic moment in the diamagnetic substances

**Ans. (b)** Ferromagnetic substances can be magnetised by applying magnetic field to it and magnetic property persist within it even after removal of magnetic field.  
Hence, choice (b) is the correct answer while other three choices are correct.

**Q. 31** Which of the following is not true about the ionic solids?

- (a) Bigger ions form the close packed structure
- (b) Smaller ions occupy either the tetrahedral or the octahedral voids depending upon their size
- (c) Occupation of all the voids is not necessary
- (d) The fraction of octahedral or tetrahedral voids occupied depends upon the radii of the ions occupying the voids

**Ans. (d)** The fraction of octahedral or tetrahedral voids occupied depends upon the radii of the ions present at the lattice points. As we know the radii of octahedral or tetrahedral void is related to radii of atoms ( $r$ ) as

$$\text{Radius of octahedral void } (R_o) = 0.414 r$$

$$\text{Radius of tetrahedral void } (R_t) = 0.225 r$$

Where,  $r$  = radius of bigger atom involved.

**Q. 32** A ferromagnetic substance becomes a permanent magnet when it is placed in a magnetic field because .....

- (a) all the domains get oriented in the direction of magnetic field
- (b) all the domains get oriented in the direction opposite to the direction of magnetic field
- (c) domains get oriented randomly
- (d) domains are not affected by magnetic field

**Ans. (a)** When a ferromagnetic substance is placed in a magnetic field it becomes a permanent magnet because all the domains get oriented in the direction of magnetic field even after removal of applied magnetic field.

**Q. 33** The correct order of the packing efficiency in different types of unit cells is .....

- (a) fcc < bcc < simple cubic
- (b) fcc > bcc > simple cubic
- (c) fcc < bcc > simple cubic
- (d) bcc < fcc > simple cubic

**Ans. (b)** Packing efficiency in different types of unit cells can be tabulated as

Unit cell	Packing efficiency
fcc	74%
bcc	68%
Simple cubic	52%

Hence, correct order is fcc (74%) > bcc (68%) > simple cubic (52%).

**Q. 34** Which of the following defects is also known as dislocation defect?

- (a) Frenkel defect
- (b) Schottky defect
- (c) Non-stoichiometric defect
- (d) Simple interstitial defect

**Ans. (a)** Frenkel defect is also known as dislocation defect because in Frenkel defect atoms present in crystal lattice is dislocated to interstitial site.



**Q. 35** In the cubic close packing, the unit cell has .....

- (a) 4 tetrahedral voids each of which is shared by four adjacent unit cells  
 (b) 4 tetrahedral voids within the unit cell  
 (c) 8 tetrahedral voids each of which is shared by four adjacent unit cells  
 (d) 8 tetrahedral voids within the unit cells

**Ans. (d)** In the cubic close packing the unit cell has 8 tetrahedral voids within it and are located at each eight smaller cube of an unit cell.

**Q. 36** The edge lengths of the unit cells in terms of the radius of spheres constituting fcc, bcc and simple cubic unit cells are respectively .....

- (a)  $2\sqrt{2}r, \frac{4r}{\sqrt{3}}, 2r$  (b)  $\frac{4r}{\sqrt{3}}, 2\sqrt{2}r, 2r$   
 (c)  $2r, 2\sqrt{2}r, \frac{4r}{\sqrt{3}}$  (d)  $2r, \frac{4r}{\sqrt{3}}, 2\sqrt{2}r$

**Ans. (a)** Edge length for different types of unit cells can be tabulated as

Types of unit cell	Edge length
fcc	$2\sqrt{2}r$
bcc	$\frac{4}{\sqrt{3}}r$
scc	$2r$

**Q. 37** Which of the following represents correct order of conductivity in solids?

- (a)  $\kappa_{\text{metals}} \gg \kappa_{\text{insulators}} < \kappa_{\text{semiconductors}}$   
 (b)  $\kappa_{\text{metals}} \ll \kappa_{\text{insulators}} < \kappa_{\text{semiconductors}}$   
 (c)  $\kappa_{\text{metals}} \approx \kappa_{\text{semiconductors}} > \kappa_{\text{insulators}} = \text{ZERO}$   
 (d)  $\kappa_{\text{metals}} < \kappa_{\text{semiconductors}} > \kappa_{\text{insulators}} \neq \text{ZERO}$

### Thinking Process

Look at the option and choose the correct answer using the concept that metal have maximum value of  $\kappa$  and insulator has minimum value.

**Ans. (a)** Conductivity of metal, insulator and semiconductors can be represented in the term of  $\kappa$  (Kappa) which depends upon energy gap between valence band and conduction band.

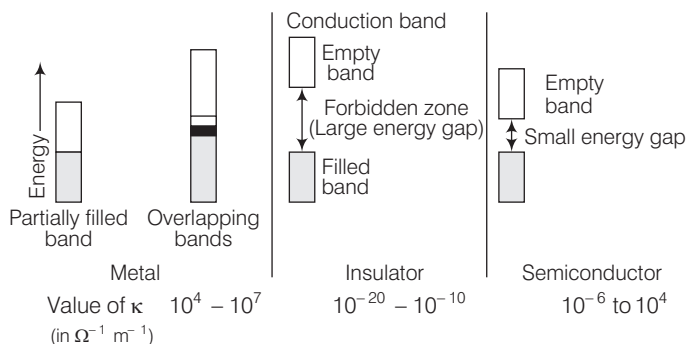

Hence, correct order is

$$\kappa_{\text{metals}} \gg \kappa_{\text{insulators}} < \kappa_{\text{semiconductors}}$$

## Multiple Choice Questions (More Than One Options)

**Q. 38** Which of the following is not true about the voids formed in 3 dimensional hexagonal close packed structure?

- (a) A tetrahedral void is formed when a sphere of the second layer is present above triangular void in the first layer
- (b) All the triangular voids are not covered by the spheres of the second layer
- (c) Tetrahedral voids are formed when the triangular voids in the second layer lie above the triangular voids in the first layer and the triangular shapes of these voids do not overlap
- (d) Octahedral voids are formed when the triangular voids in the second layer exactly overlap with similar voids in the first layer

**Ans. (c, d)**

Tetrahedral voids are formed when the triangular void in the second layer lie exactly above the triangular voids in the first layer and the triangular shape of these voids oppositely overlap.

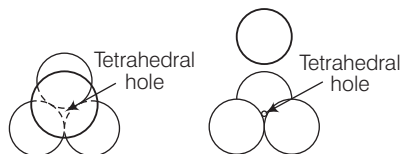

Octahedral voids are formed when triangular void of second layer is not exactly overlap with similar void in first layer.

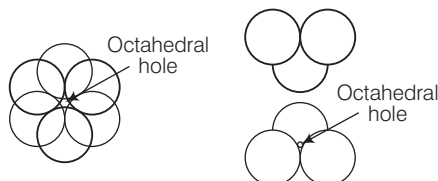

**Q. 39** The value of magnetic moment is zero in the case of antiferromagnetic substances because the domains .....

- (a) get oriented in the direction of the applied magnetic field
- (b) get oriented opposite to the direction of the applied magnetic field
- (c) are oppositely oriented with respect to each other without the application of magnetic field
- (d) cancel out each other's magnetic moment

**Ans. (c, d)**

In the case of antiferromagnetic substances, the magnetic moment becomes zero because the domains are oppositely oriented with respect to each other without the application of magnetic field which cancel out each other.

**Q. 40** Which of the following statements are not true?

- (a) Vacancy defect results in a decrease in the density of the substance
- (b) Interstitial defects results in an increase in the density of the substance
- (c) Impurity defect has no effect on the density of the substance
- (d) Frenkel defect results in an increase in the density of the substance

**Ans. (c, d)**

Statements (c) and (d) can be correctly written as (c) Impurity defect changes the density of substance as impurity has different density than the ion present on perfect crystal. e.g., When  $\text{SrCl}_2$  is added to the NaCl crystal it causes impurity defect.

(d) Frenkel defect results neither decrease nor increase in density of substance.

**Q. 41** Which of the following statements are true about metals?

- (a) Valence band overlaps with conduction band
- (b) The gap between valence band and conduction band is negligible
- (c) The gap between valence band and conduction band cannot be determined
- (d) Valence band may remain partially filled

**Ans. (a, b, d)**

Option (a), (b) and (d) are true, option (c) can be correctly stated as the gap between valence band and conduction band can be determined. The gap between valence band and conduction band decide the conductivity of material.

**Q. 42** Under the influence of electric field, which of the following statement is true about the movement of electrons and holes in a p-type semiconductor?

- (a) Electron will move towards the positively charged plate through electron holes
- (b) Holes will appear to be moving towards the negatively charged plate
- (c) Both electrons and holes appear to move towards the positively charged plate
- (d) Movement of electrons is not related to the movement of holes

**Ans. (a, b)**

In p-type semiconductor, the conductivity is due to existence of hole. When electric field is applied to p-type semiconductor hole starts moving towards negatively charged plate and electron towards positively charged plate.

**Q. 43** Which of the following statements are true about semiconductors?

- (a) Silicon doped with electron rich impurity is a p-type semiconductor
- (b) Silicon doped with an electron rich impurity is an n-type semiconductor
- (c) Delocalised electrons increase the conductivity of doped silicon
- (d) An electron vacancy increases the conductivity of n-type semiconductor

**Ans. (b, c)**

Silicon doped with an electron rich impurity is an n-type semiconductor. Conductivity of n-type semiconductor is due to presence of free electron delocalisation of electrons increases the conductivity of doped silicon due to increase in mobility of electron.

**Q. 44** An excess of potassium ions makes KCl crystals appear violet or lilac in colour since .....

- (a) some of the anionic sites are occupied by an unpaired electron
- (b) some of the anionic sites are occupied by a pair of electrons
- (c) there are vacancies at some anionic sites
- (d) F-centres are created which impart colour to the crystals

**Ans. (a, d)**

When KCl crystals are heated it leads the disposition of potassium ion on surface of KCl. The  $\text{Cl}^-$  ions diffuse to the surface of crystal and loss electron by potassium atom to form  $\text{K}^+$  ion released electron occupies anionic site which is known as F-centre and impart colour to the crystal.

**Q. 45** The number of tetrahedral voids per unit cell in NaCl crystal is .....

- (a) 4
- (b) 8
- (c) twice the number of octahedral voids
- (d) four times the number of octahedral voids

**Ans. (b, c)**

NaCl has a rock salt type structure having fcc arrangement.

Total number of atoms per unit cell = 4

∴ Number of tetrahedral voids =  $2 \times 4 = 8$

Number of octahedral voids = 4

Hence, (b) and (c) are correct choices.

**Q. 46** Amorphous solids can also be called .....

- (a) pseudo solids
- (b) true solids
- (c) super cooled liquids
- (d) super cooled solids

**Ans. (a, c)**

Amorphous solid has short range order which has a tendency to flow very slowly. Hence, it is also known as pseudo solids or super cooled liquids. Glass panes fixed to windows or doors of old buildings are invariably observed to be thicker at bottom than at the top. These are examples of amorphous solids.

**Q. 47** A perfect crystal of silicon (fig) is doped with some elements as given in the options. Which of these options shows n-type semiconductors?

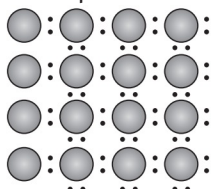

Pure crystal

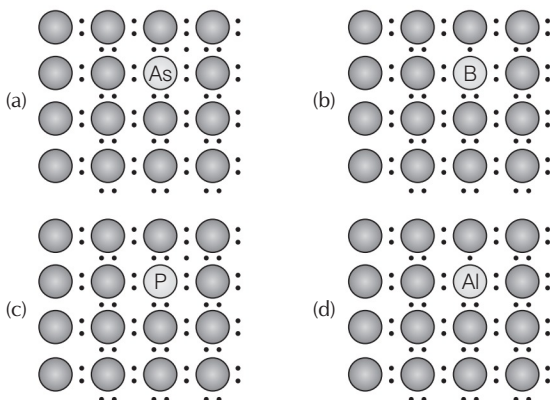

**Ans. (a, c)**

**n-type semiconductor** When group 15 elements are doped into a perfect crystal it leads to formation of n-type semiconductor.

Here, in (a) as (group 15, period 3) is doped to perfect Si-crystal and in (c) as (group 15, period 2) is doped to perfect Si-crystal.

**Q. 48** Which of the following statements are correct?

- (a) Ferrimagnetic substances lose ferrimagnetism on heating and become paramagnetic
- (b) Ferrimagnetic substances do not lose ferrimagnetism on heating and remain ferrimagnetic
- (c) Antiferromagnetic substances have domain structures similar to ferromagnetic substances and their magnetic moments are not cancelled by each other
- (d) In ferromagnetic substances, all the domains get oriented in the direction of magnetic field and remain as such even after removing magnetic field

**Ans. (a, d)**

Ferrimagnetic substances lose ferrimagnetism on heating and become paramagnetic. In ferrimagnetic substance domains are aligned in parallel and antiparallel direction in unequal numbers.

In ferromagnetic substances, all the domains get oriented in the direction of magnetic field and remain as such even after removing magnetic field.

Hence, (a) and (d) are correct choices.

**Q. 49** Which of the following features are not shown by quartz glass?

- (a) This is a crystalline solid
- (b) Refractive index is same in all the directions
- (c) This has definite heat of fusion
- (d) This is also called super cooled liquid

**Ans. (a, c)**

Quartz glass is an amorphous solid so it has not definite heat of fusion. This is due to short range order of molecule while quartz glass is also known as super cooled liquid and isotropic in nature.

**Q. 50** Which of the following cannot be regarded as molecular solid?

- (a) SiC (silicon carbide)
- (b) AlN
- (c) Diamond
- (d) I<sub>2</sub>

**Ans. (a, b, c)**

SiC, AlN and diamond are examples of network solid as they have three dimensional structure while, I<sub>2</sub> is a molecular solid, because such solid particles are held together by dipole-dipole interactions.

**Q. 51** In which of the following arrangements octahedral voids are formed?

- (a) hcp
- (b) bcc
- (c) simple cubic
- (d) fcc

**Ans. (a, d)**

In hcp and fcc arrangement octahedral voids are formed. In fcc the octahedral voids are observed at edge and centre of cube while in bcc and simple cubic, no any octahedral voids are observed.

**Q. 52** Frenkel defect is also known as .....

- (a) stoichiometric defect
- (b) dislocation defect
- (c) impurity defect
- (d) non-stoichiometric defect

**Ans. (a, b)**

Frenkel defect arises when the smaller ion (usually cation) is dislocated from its original site to interstitial site, this is also known as dislocation defect. Since, stoichiometry of substance persist so, it is categorised as stoichiometric defect.

**Q. 53** Which of the following defects decrease the density?

- (a) Interstitial defect                      (b) Vacancy defect  
(c) Frenkel defect                            (d) Schottky defect

**Ans. (b, d)**

Vacancy and Schottky defects which lead to decrease the density both are the types of a stoichiometric defect. In case of Frenkel defect and interstitial defect, there is no change in density of substance.

## Short Answer Type Questions

**Q. 54** Why are liquids and gases categorised as fluids?

**Ans.** Liquids and gases have the tendency to flow, *i.e.*, their molecules can move freely from one place to another. Therefore, they are known as fluids. *e.g.*, glass panes fixed to windows or doors of old buildings are sometimes found to be thicker at bottom. This is due to ability of glass to flow.

**Q. 55** Why are solids incompressible?

**Ans.** The distance between the constituent particles is very less in solids. On bringing them still closer repulsion will start between electron clouds of these particles. Hence, they cannot be brought further close together and are incompressible.

**Q. 56** In spite of long range order in the arrangement of particles why are the crystals usually not perfect?

**Ans.** Crystals have long range repeated pattern of arrangement of constituent particles but in the process of crystallisation some deviations from the ideal arrangement (*i.e.*, defects) may be introduced, therefore, crystals are usually not perfect.

**Q. 57** Why does table salt, NaCl sometimes appear yellow in colour?

**Ans.** Yellow colour in NaCl is due to metal excess defect due to which unpaired electrons occupy anionic sites, known as F-centres. These electrons absorb energy from the visible region for the excitation which makes crystal appear yellow.

**Q. 58** Why is FeO(s) not formed in stoichiometric composition?

**Ans.** In the crystals of FeO, some of the Fe<sup>2+</sup> cations are replaced by Fe<sup>3+</sup> ions. Three Fe<sup>2+</sup> ions are replaced by two Fe<sup>3+</sup> ions to make up the loss of positive charge. Eventually there would be less amount of metal as compared to stoichiometric composition.

**Q. 59** Why does white ZnO (s) becomes yellow upon heating?

**Ans.** On heating ZnO loses oxygen as follows

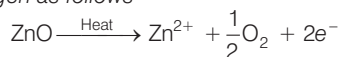

Zn<sup>2+</sup> ions and electrons move to interstitial sites and F-centres are formed which impart yellow colour to ZnO(s).

**Q. 60** Why does the electrical conductivity of semiconductors increase with rise in temperature?

**Ans.** The gap between conduction band and valence band is small in semiconductors. Therefore, electrons from the valence band can jump to the conduction band on increasing temperature. Thus, they become more conducting as the temperature increases.

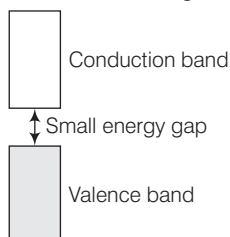

**Q. 61** Explain why does conductivity of germanium crystals increase on doping with gallium?

**Ans.** On doping germanium with gallium some of the positions of lattice of germanium are occupied by gallium. Gallium atom has only three valence electrons. Therefore, fourth valency of nearby germanium atom is not satisfied and the place remains vacant.

This place is deficient of electrons and is therefore called electron hole or electron vacancy. Electron from neighbouring atom comes and fills the hole, thereby creating a hole in its original position.

Under the influence of electric field electrons move towards positively charged plates through these and conduct electricity. The holes appear to move towards negatively charged plates.

**Q. 62** In a compound, nitrogen atoms (N) make cubic close packed lattice and metal atoms (M) occupy one-third of the tetrahedral voids present. Determine the formula of the compound formed by M and N?

**Ans.** Let the number of N atoms in ccp is  $x$

$$\therefore \text{Number of tetrahedral voids} = 2x$$

$$\therefore \text{Number of } M \text{ atoms} = \frac{1}{3} \times 2x$$

$$\frac{\text{Number of N atoms}}{\text{Number of } M \text{ atoms}} = \frac{3x}{2x} = \frac{3}{2}$$

So, the formula of the compound is  $M_2N_3$ .

**Q. 63** Under which situations can an amorphous substance change to crystalline form?

**Ans.** On heating, amorphous substances change to crystalline form at some temperature some objects from ancient civilisation are found to be milky in appearance. This is due to crystallisation.

## Matching The Columns

**Q. 64** Match the defects given in Column I with the statements in given Column II.

	Column I	Column II
A.	Simple vacancy defect	1. Shown by non-ionic solids and increases density of the solid
B.	Simple interstitial defect	2. Shown by ionic solids and decreases density of the solid
C.	Frenkel defect	3. Shown by non-ionic solids and density of the solid decreases
D.	Schottky defect	4. Shown by ionic solids and density of the solid remains the same

**Ans.** A. → (3)    B. → (1)    C. → (4)    D. → (2)

A. When some of lattice sites are vacant in any non-ionic solid, the crystal is said to have vacancy defect and due to decrease in number of particles present in crystal lattice the density of crystal decreases.

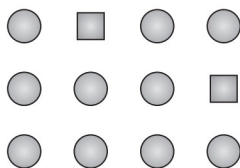

Vacancy defects

B. Simple interstitial defect are shown by non-ionic solids in which constituent particles is displaced from its normal site to an interstitial site. Hence, density of solid increases.

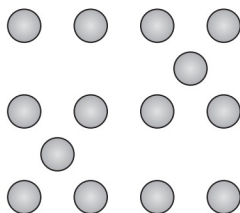

Interstitial defects

C. Frenkel defect is shown by ionic solids in which smaller ions get dislocated from its normal site to its interstitial site which lead to decrease its density.

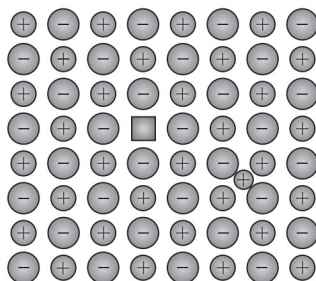

Frenkel defects



D. Schottky defect is shown by ionic solids in which equal number of cation and anion get missed from ionic solids and thus, density of solid decreases.

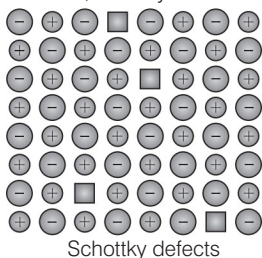

**Q. 65** Match the type of unit cell given in Column I with the features given in Column II.

Column I	Column II
A. Primitive cubic unit cell	1. Each of the three perpendicular edges compulsorily have the different edge length <i>i.e.</i> , $a \neq b \neq c$
B. Body centred cubic unit cell	2. Number of atoms per unit cell is one
C. Face centred cubic unit cell	3. Each of the three perpendicular edges compulsorily have the same edge length <i>i.e.</i> , $a = b = c$
D. End centred orthorhombic unit cell	4. In addition to the contribution from the corner atoms the number of atoms present in a unit cell is one
	5. In addition to the contribution from the corner atoms the number of atoms present in a unit cell is three

**Ans.** A.  $\rightarrow$  (2, 3)    B.  $\rightarrow$  (3, 4)    C.  $\rightarrow$  (3, 5)    D.  $\rightarrow$  (1, 4)

A. For primitive unit cell,  $a = b = c$

$$\text{Total number of atoms per unit cell} = 1/8 \times 8 = 1$$

Here,  $1/8$  is due to contribution of each atom present at corner.

B. For body centred cubic unit cell,  $a = b = c$

This lattice contain atoms at corner as well as body centre. Contribution due to atoms at corner =  $1/8 \times 8 = 1$  contribution due to atoms at body centre = 8

C. For face centred unit cell,  $a = b = c$

$$\text{Total constituent ions per unit cell present at corners} = \frac{1}{8} \times 8 = 1$$

$$\text{Total constituent ions per unit cell present at face centre} = \frac{1}{2} \times 6 = 3$$

D. For end centred orthorhombic unit cell,  $a \neq b \neq c$

$$\text{Total contribution of atoms present at corner} = \frac{1}{8} \times 8 = 1$$

$$\text{Total contribution of atoms present at end centre} = \frac{1}{2} \times 2 = 1$$

Hence, other than corner it contain total one atom per unit cell.

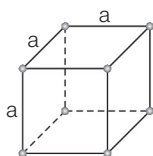

Primitive  
(or simple)

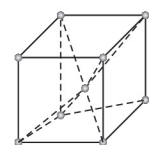

Body centred

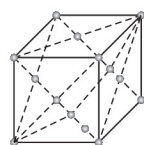

Face centred

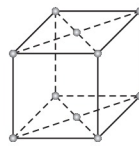

End centred

**Q. 66** Match the types of defect given in Column I with the statement given in Column II.

Column I	Column II
A. Impurity defect	1. NaCl with anionic sites called F-centres
B. Metal excess defect	2. FeO with $\text{Fe}^{3+}$
C. Metal deficiency defect	3. NaCl with $\text{Sr}^{2+}$ and some cationic sites vacant

**Ans.** A.  $\rightarrow$  (3)    B.  $\rightarrow$  (1)    C.  $\rightarrow$  (2)

- A. Impurity defect arises due to replacement of one common ion present in any crystal by another uncommon ion.
- B. Metal excess defect is due to missing of cation from ideal ionic solid which lead to create a F-centre generally occupied by unpaired electrons. e.g., NaCl with anionic site.
- C. Metal deficiency defect In FeO,  $\text{Fe}^{3+}$  exists along with  $\text{Fe}^{2+}$  which lead to decrease in metal ion(s) so this is a type of metal deficiency defect.

**Q. 67** Match the items given in Column I with the items given in Column II.

Column I	Column II
A. Mg in solid state	1. $p$ -type semiconductor
B. $\text{MgCl}_2$ in molten state	2. $n$ -type semiconductor
C. Silicon with phosphorus	3. Electrolytic conductors
D. Germanium with boron	4. Electronic conductors

**Ans.** A.  $\rightarrow$  (4)    B.  $\rightarrow$  (3)    C.  $\rightarrow$  (2)    D.  $\rightarrow$  (1)

- A. Mg in solid state show electronic conductivity due to presence of free electrons hence, they are known as electronic conductors.
- B.  $\text{MgCl}_2$  in molten state show electrolytic conductivity due to presence of electrolytes in molten state.
- C. Silicon doped with phosphorus contain one extra electron due to which it shows conductivity under the influence of electric field and known as  $p$ -type semiconductor.
- D. Germanium doped with boron contain one hole due to which it shows conductivity under the influence of electric field and known as  $n$ -type semiconductor.

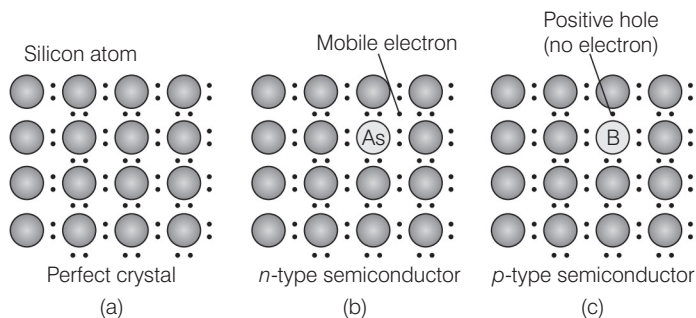

**Q. 68** Match the type of packing given in Column I with the items given in Column II.

Column I	Column II
A. Square close packing in two dimensions	1. Triangular voids
B. Hexagonal close packing in two dimensions	2. Pattern of spheres is repeated in every fourth layer
C. Hexagonal close packing in three dimensions	3. Coordination number = 4
D. Cubic close packing in three dimensions	4. Pattern of sphere is repeated in alternate layers

**Ans.** A. → (3)    B. → (1)    C. → (4)    D. → (2)

A. Square close packing in two dimensions each sphere have coordination number 4, as shown below

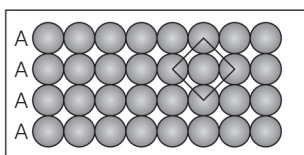

B. Hexagonal close packing in two dimensions each sphere have coordination number 6 as shown below and creates a triangular void

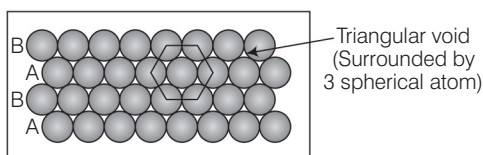

C. Hexagonal close packing in 3 dimensions is a repeated pattern of sphere in alternate layers also known as *ABAB* pattern

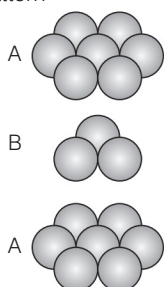

D. Cubic close packing in a 3 dimensions is a repeating pattern of sphere in every fourth layer

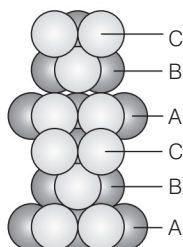

## Assertion and Reason

*In the following questions a statement of Assertion (A) followed by a statement of Reason (R) is given. Choose the correct answer out of the following choices.*

- (a) Assertion and Reason both are correct statements and Reason is correct explanation for Assertion.
- (b) Assertion and Reason both are correct statements but Reason is not correct explanation for Assertion.
- (c) Assertion is correct statement but Reason is wrong statement.
- (d) Assertion is wrong statement but Reason is correct statement.

**Q. 69 Assertion (A)** The total number of atoms present in a simple cubic unit cell is one.

**Reason (R)** Simple cubic unit cell has atoms at its corners, each of which is shared between eight adjacent unit cells.

**Ans. (a)** In simple cubic unit cell each atom is present at corners having contribution  $1/8$ .

Hence, total number of atoms present per unit cell in scc is  $\frac{1}{8} \times 8 = 1$ .

**Q. 70 Assertion (A)** Graphite is a good conductor of electricity however diamond belongs to the category of insulators.

**Reason (R)** Graphite is soft in nature on the other hand diamond is very hard and brittle.

**Ans. (b)** Assertion and Reason both are correct but Reason is not correct explanation of Assertion.

Correct explanation is that graphite have layered structure with free electrons due to which it is a good conductor of electricity. On the other hand, diamond have tetrahedral arrangement with no unpaired electron. Therefore, diamond is hard and brittle but insulator.

**Q. 71 Assertion (A)** Total number of octahedral voids present in unit cell of cubic close packing including the one that is present at the body centre, is four.

**Reason (R)** Besides the body centre there is one octahedral void present at the centre of each of the six faces of the unit cell and each of which is shared between two adjacent unit cells.

**Ans. (c)** Assertion is correct statement but Reason is incorrect statement.

**Assertion** is true as in ccp atom present at face centre and corner of each unit cell which creates octahedral void at each body centre and all twelve edges of a unit cell as shown below

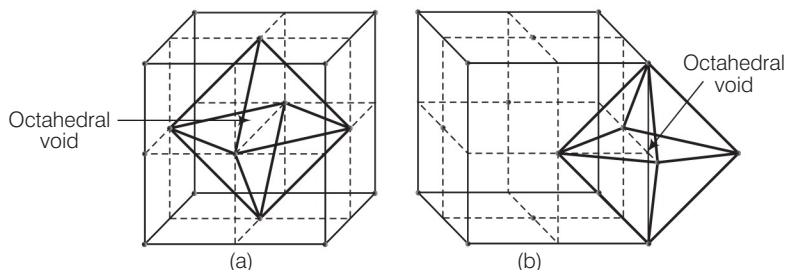

Correct reason is that beside the body centre there is one octahedral void at centre of each of 12 edges which is surrounded by six atoms.

Out of six atoms four belongs to same unit cell (2 at corner and 2 at face centre) and 2 atoms belongs to adjacent unit cell.

**Q. 72 Assertion (A)** The packing efficiency is maximum for the fcc structure.

**Reason (R)** The coordination number is 12 in fcc structures.

**Ans. (b)** Assertion and Reason both are correct statements but reason is not the correct explanation of Assertion.

Correct reason is that, packing efficiency is maximum for fcc structure because it consists of total four atoms per unit cell. Packing efficiency is maximum in fcc structure which is equal to 74%.

**Q. 73 Assertion (A)** Semiconductors are solids with conductivities in the intermediate range from  $10^{-6} - 10^4 \text{ ohm}^{-1} \text{ m}^{-1}$ .

**Reason (R)** Intermediate conductivity in semiconductor is due to partially filled valence band.

**Ans. (c)** Assertion is correct statement but reason is incorrect statement.

Semiconductors are solids with conductivities in the intermediate range vary from  $10^{-6} - 10^4 \text{ } \Omega^{-1} \text{ m}^{-1}$ . Intermediate conductivity is due to small energy gap between valence band and conduction band.

(Also, refer to Q. 60)

## Long Answer Type Questions

**Q. 74** With the help of a labelled diagram show that there are four octahedral voids per unit cell in a cubic close packed structure.

**Ans.** Cubic close packed structure contains one atom at each of eight corners of a unit cell and one atom at each of six faces which can be represented below

As we know any atom surrounded by six atoms (hard sphere) creates an octahedral void. In case of fcc body centre is surrounded by six identical atoms present at face centre hence, there is an octahedral void at body centre of each unit cell.

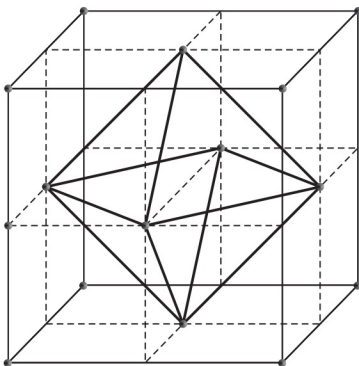

**Location of octahedral voids per unit cell of ccp or fcc lattice at the body centre of the cube**

Beside the body centre there is one octahedral void at centre of each of 12 edge as shown below

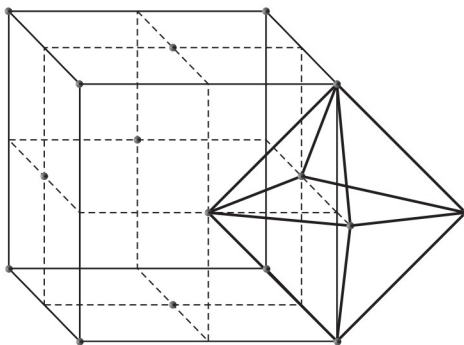

**Octahedral void at centre of each edge**

Since, each void is shared by 4 unit cell. Therefore, contribution of octahedral void to each edge of a unit cell is  $\frac{1}{4}$ .

Number of octahedral void at centre of 12 edge =  $\frac{1}{4} \times 12 = 3$

Number of octahedral void at body centre = 1

Therefore, total number of octahedral void at each ccp lattice =  $3 + 1 = 4$

**Q. 75** Show that in a cubic close packed structure, eight tetrahedral voids are present per unit cell.

**Ans.** Cubic close packed structure contains one atom at each corner of a unit cell and at face centre of each unit cell. Each unit cell consists of 8 small cubes.

Each small cube contains 4 atoms at its alternate corner when these atoms are joined to each other lead to creation of a tetrahedral void as shown below

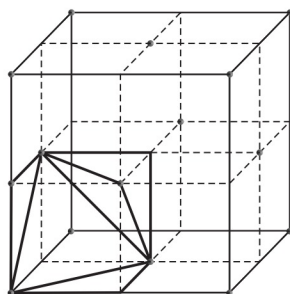

(a)  
**Eight tetrahedral voids per unit cell of ccp structure**

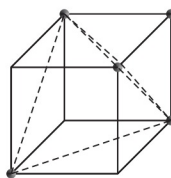

(b)  
**One tetrahedral void showing the geometry**

Since, there are total 8 smaller cubes present at one unit cell and each smaller cube has one tetrahedral void hence, total number of tetrahedral void present in each unit cell is equal to eight.

As we know ccp structure has 4 atoms per unit cell. Thus, total number of tetrahedral void in one ccp unit cell is equal to 8.

**Q. 76** How does the doping increase the conductivity of semiconductors?

**Ans.** Conductivity of a semiconductor is too low for practical use. The conductivity of a semiconductor can be increased by adding a suitable amount of impurity to perfect crystal. This process is known as doping. It can be done by adding either of two types of impurity to the crystal.

(A) By adding **electron rich impurities** *i.e.*, group 15 elements to the silicon and germanium of group 14 elements. Out of 4 valence electrons of group 14 elements and 5 valence electrons of group 15 elements, four electrons of each element led to formation of four covalent bonds while the one extra electron of group 15 elements become delocalised.

Thus, increases conductivity of semiconductor. This type of semiconductor is known as *n*-type semiconductor.

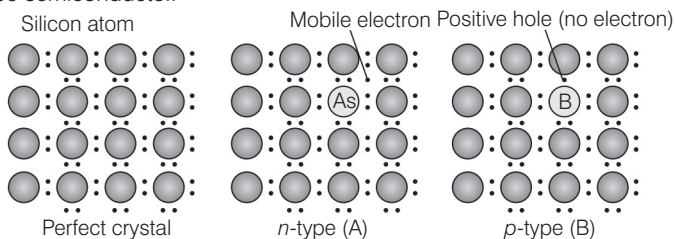

**Creation of *n*-type and *p*-type semiconductors by doping groups 13 and 15 elements**

(B) By adding **electron deficient impurity** i.e., group 14 to the perfect crystal of group 14 elements when group 13 element is doped to group 14 element it lead to create a hole in the ideal crystal which is known as electron hole or electron vacancy.

An electron from the neighbouring atom come and fill the electron hole in doing so an electron from the neighbour leaves an electron hole to its original position. Thus, it increases conductivity of semiconductor. This type of semiconductor is known as  $p$ -type semiconductor.

**Q. 77** A sample of ferrous oxide has actual formula  $\text{Fe}_{0.93}\text{O}_{1.00}$ . In this sample, what fraction of metal ions are  $\text{Fe}^{2+}$  ions? What type of non-stoichiometric defect is present in this sample?

**Thinking Process**

Consider the number of  $\text{Fe}^{2+}$  and  $\text{Fe}^{3+}$  ions as  $x$  and  $y$  then write their sum equal to 0.93. Write another equation in terms of  $x$  and  $y$  by taking the sum of their total charge equal to 2 [charge on oxygen]. Now using the substitution method. Calculate the value of  $x$  and  $y$  then calculate fraction of  $\text{Fe}^{2+}$  ion present in this sample.

**Ans.** Let the formula of the sample be  $(\text{Fe}^{2+})_x (\text{Fe}^{3+})_y \text{O}$

On looking at the given formula of the compound

$$x + y = 0.93 \quad \dots(i)$$

Total positive charge on ferrous and ferric ions should balance the two units of negative charge on oxygen

Therefore,  $2x + 3y = 2 \quad \dots(ii)$

$$\Rightarrow x + \frac{3}{2}y = 1 \quad \dots(iii)$$

On subtracting equation (i) from equation (iii) we have

$$\frac{3}{2}y - y = 1 - 0.93$$

$$\Rightarrow \frac{1}{2}y = 0.07$$

$$\Rightarrow y = 0.14$$

On putting the value of  $y$  in equation (i), we get

$$x + 0.14 = 0.93$$

$$\Rightarrow x = 0.93 - 0.14$$

$$\Rightarrow x = 0.79$$

$$\text{Fraction of } \text{Fe}^{2+} \text{ ions present in the sample} = \frac{0.79}{0.93} = 0.849$$

Metal deficiency defect is present in the sample because iron is less in amount than that required for stoichiometric composition.



# 2

## Solutions

### Multiple Choice Questions (MCQs)

**Q. 1** Which of the following units is useful in relating concentration of solution with its vapour pressure?

- (a) Mole fraction (b) Parts per million  
(c) Mass percentage (d) Molality

**Ans. (a)** According to Henry's law partial pressure of gas in the solution is proportional to the mole fraction of gas in the solution.

$$p = K_H x$$

where,  $K_H$  = Henry's constant

Hence, (a) mole fraction is the correct choice.

**Q. 2** On dissolving sugar in water at room temperature solution feels cool to touch. Under which of the following cases dissolution of sugar will be most rapid?

- (a) Sugar crystals in cold water (b) Sugar crystals in hot water  
(c) Powdered sugar in cold water (d) Powdered sugar in hot water

#### 💡 Thinking Process

*Use the concept of solubility and effect of temperature on solubility to answer this question.*

**Ans. (d)** Dissolution of sugar in water will be most rapid when powdered sugar is dissolved in hot water because powder form can easily insert in the vacancies of liquid particles.

Further dissolution of sugar in water is an endothermic process. Hence, high temperature will favour the dissolution of sugar in water.

**Q. 3** At equilibrium the rate of dissolution of a solid solute in a volatile liquid solvent is .....

- (a) less than the rate of crystallisation  
(b) greater than the rate of crystallisation  
(c) equal to the rate of crystallisation  
(d) zero

**Ans. (c)** At equilibrium the rate of dissolution of solid in a volatile liquid solvent is equal to the rate of crystallisation.

**Q. 4** A beaker contains a solution of substance 'A'. Precipitation of substance 'A' takes place when small amount of 'A' is added to the solution. The solution is .....

- (a) saturated (b) supersaturated  
(c) unsaturated (d) concentrated

**💡 Thinking Process**

*This problem includes concept of saturated, unsaturated, supersaturated and concentrated solution.*

**Ans. (b)** When solute is added to the solution three cases may arise

- (i) It dissolves into solution then solution is unsaturated.  
(ii) It does not dissolve in the solution then solution is known as saturated.  
(iii) When solute get precipitated solution is known as supersaturated solution.

**Q. 5** Maximum amount of a solid solute that can be dissolved in a specified amount of a given liquid solvent does not depend upon .....

- (a) temperature (b) nature of solute  
(c) pressure (d) nature of solvent

**Ans. (c)** Maximum amount of solid that can be dissolved in a specified amount of a given solvent does not depend upon pressure. This is because solid and liquid are highly incompressible and practically remain unaffected by change in pressure.

**Q. 6** Low concentration of oxygen in the blood and tissues of people living at high altitude is due to .....

- (a) low temperature  
(b) low atmospheric pressure  
(c) high atmospheric pressure  
(d) Both low temperature and high atmospheric pressure

**Ans. (b)** Low concentration of oxygen in the blood and tissues of people living at high altitude is due to low atmospheric pressure. Because at high altitude, the partial pressure of oxygen is less than at the ground level. This decreased atmospheric pressure causes release of oxygen from blood.

**Q. 7** Considering the formation, breaking and strength of hydrogen bond, predict which of the following mixtures will show a positive deviation from Raoult's law?

- (a) Methanol and acetone (b) Chloroform and acetone  
(c) Nitric acid and water (d) Phenol and aniline

**Ans. (a)** In pure methanol, molecules are hydrogen bonded. On adding acetone, its molecules get in between the host molecules and break some of the hydrogen bonds between them.

Therefore, the intermolecular attractive forces between the solute-solvent molecules are weaker than those between the solute-solute and solvent-solvent molecules.

On the other hand, other three remaining options will show negative deviation from Raoult's law where the intermolecular attractive forces between the solute-solvent molecules are stronger than those between the solute-solute and solvent-solvent molecules.

**Q. 8** Colligative properties depend on .....

- (a) the nature of the solute particles dissolved in solution  
 (b) the number of solute particles in solution  
 (c) the physical properties of the solute particles dissolved in solution  
 (d) the nature of solvent particles

**Ans. (b)** Colligative properties depend upon number of solute particles in solution irrespective of their nature. Colligative property is used to determine the molecular mass of particle.

**Q. 9** Which of the following aqueous solutions should have the highest boiling point?

- (a) 1.0 M NaOH  
 (b) 1.0 M Na<sub>2</sub>SO<sub>4</sub>  
 (c) 1.0 M NH<sub>4</sub>NO<sub>3</sub>  
 (d) 1.0 M KNO<sub>3</sub>

**Thinking Process**

*This process includes concept of van't Hoff factor and boiling point. Calculate van't Hoff factor then correlate it with boiling point of solution.*

**Ans. (b)** As we know greater the value of van't Hoff factor higher will be the elevation in boiling point and hence higher will be the boiling point of solution.

Solution	van't Hoff factor (i)
1.0 M NaOH	2
1.0 M Na <sub>2</sub> SO <sub>4</sub>	3
1.0 M NH <sub>4</sub> NO <sub>3</sub>	2
1.0 M KNO <sub>3</sub>	2

Hence, 1.0 M Na<sub>2</sub>SO<sub>4</sub> has highest value of boiling point.

**Q. 10** The unit of ebullioscopic constant is

- (a) K kg mol<sup>-1</sup> or K (molality)<sup>-1</sup>  
 (b) mol kg K<sup>-1</sup> or K<sup>-1</sup> (molality)  
 (c) kg mol<sup>-1</sup> K<sup>-1</sup> or K<sup>-1</sup> (molality)<sup>-1</sup>  
 (d) K mol kg<sup>-1</sup> or K (molality)

**Thinking Process**

*Write the formula of ebullioscopic constant then put the values of their unit and then calculate unit of ebullioscopic constant.*

**Ans. (a)** As we know from elevation in boiling point that

$$\Delta T_b = K_b m$$

$$K_b = \frac{\Delta T_b}{m}$$

$$\text{Unit of } K_b = \frac{\text{unit of } \Delta T_b}{\text{unit of } m} = \frac{\text{K}}{\text{molality}}$$

$$= \frac{\text{K}}{\text{mol kg}^{-1}} = \text{K mol}^{-1} \text{ kg}$$

**Q. 11** In comparison to a 0.01 M solution of glucose, the depression in freezing point of a 0.01 M MgCl<sub>2</sub> solution is .....

- (a) the same  
 (b) about twice  
 (c) about three times  
 (d) about six times

**Thinking Process**

*Calculate value of van't Hoff factor then correlate it with colligative property of given solution.*

**Ans. (c)** As we know depression in freezing point is directly related to van't Hoff factor ( $i$ ) according to which greater the value of  $i$  greater will be the depression in freezing point.

Solution	$i$
0.01 M glucose	1
0.01 M $MgCl_2$	3

Hence, depression in freezing point of glucose is about 3 times of glucose.

**Q.12** An unripe mango placed in a concentrated salt solution to prepare pickle shrivels because .....

- (a) it gains water due to osmosis
- (b) it loses water due to reverse osmosis
- (c) it gains water due to reverse osmosis
- (d) it loses water due to osmosis

**Ans. (d)** When an unripe mango is placed in a concentrated salt solution to prepare pickle then mango loose water due to osmosis and get shrivel.

**Q. 13** At a given temperature, osmotic pressure of a concentrated solution of a substance .....

- (a) is higher than that of a dilute solution
- (b) is lower than that of a dilute solution
- (c) is same as that of a dilute solution
- (d) cannot be compared with osmotic pressure of dilute solution

**Ans. (a)** According to definition of osmotic pressure we know that  $\pi = CRT$ . For concentrated solution  $C$  has higher value than dilute solution.

Hence, as concentration of solution increases osmotic pressure will also increase.

**Q. 14** Which of the following statements is false?

- (a) Two different solutions of sucrose of same molality prepared in different solvents will have the same depression in freezing point.
- (b) The osmotic pressure of a solution is given by the equation  $\pi = CRT$  (where,  $C$  is the molarity of the solution)
- (c) Decreasing order of osmotic pressure for 0.01 M aqueous solutions of barium chloride, potassium chloride, acetic acid and sucrose is  
 $BaCl_2 > KCl > CH_3COOH > sucrose$
- (d) According to Raoult's law, the vapour pressure exerted by a volatile component of a solution is directly proportional to its mole fraction in the solution

**Ans. (a)** According to definition of depression in freezing point

$$\Delta T_f = K_f m$$

where,  $K_f$  = freezing point depression constant, value of  $K_f$  depends upon nature of solvent. This is why although the solution have same molality two different solutions of sucrose of same molality prepared in different solvents will have different depression in freezing point.

**Q. 15** The values of van't Hoff factors for KCl, NaCl and  $K_2SO_4$  respectively are

..... .

- (a) 2, 2 and 2      (b) 2, 2 and 3      (c) 1, 1 and 2      (d) 1, 1 and 1

**Ans. (b)** Number of total ions present in the solution is known as van't Hoff factors ( $i$ ).

Substances	van't Hoff factor ( $i$ )
For KCl	2
For NaCl	2
For $K_2SO_4$	3

Hence, correct choice is (b).

**Q. 16** Which of the following statements is false?

- (a) Units of atmospheric pressure and osmotic pressure are the same  
 (b) In reverse osmosis, solvent molecules move through a semipermeable membrane from a region of lower concentration of solute to a region of higher concentration  
 (c) The value of molal depression constant depends on nature of solvent  
 (d) Relative lowering of vapour pressure, is a dimensionless quantity

**Ans. (b)** In reverse osmosis, solvent molecules move through a semipermeable membrane from a region of higher concentration of solute to lower concentration.

**Q. 17** Value of Henry's constant  $K_H$  .....

- (a) increases with increase in temperature  
 (b) decreases with increase in temperature  
 (c) remains constant  
 (d) first increases then decreases

**Ans. (a)** Value of Henry's constant ( $K_H$ ) increases with increase in temperature representing the decrease in solubility.

**Q. 18** The value of Henry's constant,  $K_H$  is .....

- (a) greater for gases with higher solubility  
 (b) greater for gases with lower solubility  
 (c) constant for all gases  
 (d) not related to the solubility of gases

**Ans. (b)** According to Henry's law

$$p \propto x$$

$$\Rightarrow p = K_H x$$

As value of  $K_H$  rises solubility of gases decreases.

**Q. 19** Consider the figure and mark the correct option.

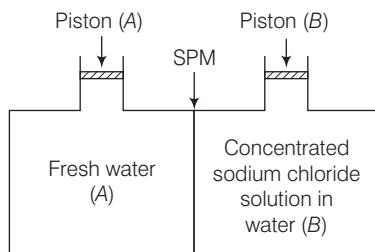

- (a) Water will move from side (A) to side (B) if a pressure lower osmotic pressure is applied on piston (B)
- (b) Water will move from side (B) to side (A) if a pressure greater than osmotic pressure is applied on piston (B)
- (c) Water will move from side (B) to side (A) if a pressure equal to osmotic pressure is applied on piston (B)
- (d) Water will move from side (A) to side (B) if pressure equal to osmotic pressure is applied on piston (A)

**Ans. (b)** We know that, if a pressure higher than the osmotic pressure is applied on the solution, the solvent will flow from the solution into the pure solvent through the semi-permeable membrane. This process is called reverse osmosis. Thus, in this case, water will move from side (B) to side (A) if a pressure greater than osmotic pressure is applied on piston (B).

**Q. 20** We have three aqueous solutions of NaCl labelled as 'A', 'B' and 'C' with concentrations 0.1 M, 0.01 M and 0.001 M, respectively. The value of van't Hoff factor for these solutions will be in the order .....

- (a)  $i_A < i_B < i_C$       (b)  $i_A > i_B > i_C$       (c)  $i_A = i_B = i_C$       (d)  $i_A < i_B > i_C$

**Ans. (b)** van't Hoff factor is the measurement of total number of ions present in the solution. Therefore, greater the concentration of solution greater will be its van't Hoff factor.

	Concentration NaCl	
A	0.1 M	On moving top to bottom
B	0.01 M	◆ Concentration decreases
C	0.001 M	◆ Van't Hoff factor( <i>i</i> ) decreases

**Q. 21** On the basis of information given below mark the correct option.

Information

- (i) In bromoethane and chloroethane mixture intermolecular interactions of A—A and B—B type are nearly same as A—B type interactions.
- (ii) In ethanol and acetone mixture A—A or B—B type intermolecular interactions are stronger than A—B type interactions.
- (iii) In chloroform and acetone mixture A—A or B—B type intermolecular interactions are weaker than A—B type interactions.
- (a) Solution (ii) and (iii) will follow Raoult's law
- (b) Solution (i) will follow Raoult's law
- (c) Solution (ii) will show negative deviation from Raoult's law
- (d) Solution (iii) will show positive deviation from Raoult's law

**Ans. (b)** For an ideal solution, the  $A-A$  or  $B-B$  type intermolecular interaction is near by equal to  $A-B$  type interaction. Here, a mixture of bromoethane and chloroethane is an example of ideal solution.

On the other hand chloroform and acetone mixture is an example of non-ideal solution having negative deviation. So, ( $A-A$ ) or ( $B-B$ ) interaction must be stronger than  $A-B$  interaction. While ethanol-acetone mixture shows positive deviation due to weaker  $A-B$  interaction in comparison to  $A-A$  or  $A-B$  interaction.

**Q. 22** Two beakers of capacity 500 mL were taken. One of these beakers, labelled as "A", was filled with 400 mL water whereas the beaker labelled "B" was filled with 400 mL of 2M solution of NaCl. At the same temperature both the beakers were placed in closed containers of same material and same capacity as shown in figure.

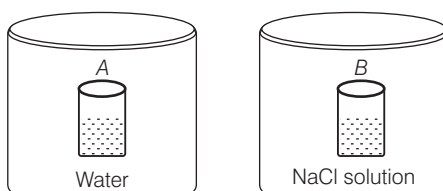

At a given temperature, which of the following statement is correct about the vapour pressure of pure water and that of NaCl solution?

- Vapour pressure in container (A) is more than that in container (B)
- Vapour pressure in container (A) is less than that in container (B)
- Vapour pressure is equal in both the containers
- Vapour pressure in container (B) is twice the vapour pressure in container (A)

**Ans. (a)** When salt is added to water to make the solution the vapour pressure of solution get decreases. This is due to decrease in surface covered by solvent molecule which lead to decrease in number of solvent molecule escaping from the surface corresponding to pure solvent.

Hence, vapour pressure also get reduces.

**Q. 23** If two liquids A and B form minimum boiling azeotrope at some specific composition then

- $A-B$  interactions are stronger than those between  $A-A$  or  $B-B$
- vapour pressure of solution increases because more number of molecules of liquids A and B can escape from the solution
- vapour pressure of solution decreases because less number of molecules of only one of the liquids escape from the solution
- $A-B$  interactions are weaker than those between  $A-A$  or  $B-B$

**Ans. (a)** If two liquids A and B form minimum boiling azeotrope at some specific composition then  $A-B$  interactions are weaker than those of  $A-A$  and  $B-B$ . It is due to the fact that in case of positive deviation, we get minimum boiling azeotropes whereas in case of negative deviation we get maximum boiling azeotropes.

**Q. 24** 4 L of 0.02 M aqueous solution of NaCl was diluted by adding 1 L of water. The molality of the resultant solution is .....

- (a) 0.004                      (b) 0.008                      (c) 0.012                      (d) 0.016

**Thinking Process**

To calculate the strength of solution when it is diluted by adding solvent. Write all the given values  $M_1, V_1, M_2$  and  $V_2$ . Then calculate required parameter using formula,

$$M_1 V_1 = M_2 V_2$$

where,

$V_1$  = volume of solution before dilution

$V_2$  = volume of solution after dilution

$M_1$  = strength of solution before dilution

$M_2$  = strength of solution after dilution

**Ans. (d)** Given,  $M_1 = 0.02\text{M}$ ,  $V_1 = 4\text{L}$ ,  $M_2 = ?$ ,  $V_2 = 4\text{L} + 1\text{L} = 5\text{L}$

As we know,

$$M_1 V_1 = M_2 V_2$$

$$0.02 \times 4\text{L} = M_2 \times 5\text{L}$$

$$M_2 = \frac{0.08}{5} = 0.016\text{M}$$

**Q. 25** On the basis of information given below mark the correct option.

**Information** On adding acetone to methanol some of the hydrogen bonds between methanol molecules break.

- (a) At specific composition methanol-acetone mixture will form minimum boiling azeotrope and will show positive deviation from Raoult's law  
 (b) At specific composition methanol-acetone mixture will form maximum boiling azeotrope and will show positive deviation from Raoult's law  
 (c) At specific composition methanol-acetone mixture will form minimum boiling azeotrope and will show negative deviation from Raoult's law  
 (d) At specific composition methanol-acetone mixture will form maximum boiling azeotrope and will show negative deviation from Raoult's law

**Ans. (a)** At specific composition methanol- acetone mixture will form minimum boiling azeotrope and will show positive deviation. This is due to weaker A—B interaction than A—A or B—B interaction. i.e.,  $A-B < A-A$  and  $B-B$

**Q. 26**  $K_H$  value for Ar(g),  $\text{CO}_2$  (g), HCHO (g) and  $\text{CH}_4$ (g) are 40.39, 1.67,  $1.83 \times 10^{-5}$  and 0.413 respectively.

Arrange these gases in the order of their increasing solubility.

- (a) HCHO <  $\text{CH}_4$  <  $\text{CO}_2$  < Ar                      (b) HCHO <  $\text{CO}_2$  <  $\text{CH}_4$  < Ar  
 (c) Ar <  $\text{CO}_2$  <  $\text{CH}_4$  < HCHO                      (d) Ar <  $\text{CH}_4$  <  $\text{CO}_2$  < HCHO

**Thinking Process**

Higher the value of  $K_H$  at a given pressure, the lower is the solubility of the gas in the liquid.

**Ans. (c)** Value of  $K_H$  depends upon nature of gases dissolved in water.

Gas	Temperature (K)	$K_H/\text{k bar}$
Ar	298 K	40.3
$\text{CO}_2$	298 K	1.67
$\text{CH}_4$	298 K	0.413
HCHO	298 K	$1.83 \times 10^{-5}$

Hence, correct order is  $\text{Ar} < \text{CO}_2 < \text{CH}_4 < \text{HCHO}$  and correct choice is (c).



## Multiple Choice Questions (More Than One Options)

**Q. 27** Which of the following factor(s) affect the solubility of a gaseous solute in the fixed volume of liquid solvent?

- (i) Nature of solute  
(ii) Temperature  
(iii) Pressure  
(a) (i) and (iii) at constant  $T$   
(b) (i) and (ii) at constant  $p$   
(c) (ii) and (iii)  
(d) Only (iii)

**Ans. (a, b)**

Solubility of gaseous solute in the fixed volume of liquid solvent always depends upon nature of solute but it depends upon pressure at constant temperature and depends upon temperature at constant pressure.

Hence, (a) and (b) both are correct.

**Q. 28** Intermolecular forces between two benzene molecules are nearly of same strength as those between two toluene molecules. For a mixture of benzene and toluene, which of the following are not true?

- (a)  $\Delta_{\text{mix}} H = \text{zero}$   
(b)  $\Delta_{\text{mix}} V = \text{zero}$   
(c) These will form minimum boiling azeotrope  
(d) These will not form ideal solution

**Ans. (c, d)**

The solution which follows Raoult's law is known as ideal solution. For an ideal solution intermolecular forces between two benzene molecules are nearly of same strength as those between two toluene molecules. For an ideal solution

$$\Delta V_{\text{mix}} = 0 \text{ and } \Delta H_{\text{mix}} = 0$$

Thus, the mixture of benzene and toluene is an example of ideal solution. Option (c) is incorrect as minimum boiling azeotropes are formed by non-ideal solution.

**Q. 29** Relative lowering of vapour pressure is a colligative property because

.....

- (a) it depends on the concentration of a non-electrolyte solute in solution and does not depend on the nature of the solute molecules  
(b) it depends on number of particles of electrolyte solute in solution and does not depend on the nature of the solute particles  
(c) it depends on the concentration of a non-electrolyte solute in solution as well as on the nature of the solute molecules  
(d) it depends on the concentration of an electrolyte or non-electrolyte solute in solution as well as on the nature of solute molecules

**Ans. (a, b)**

*Relative lowering of vapour pressure is a colligative property because*

- (i) It does not depend upon nature of solute.  
(ii) It depends upon number of solute particles.  
(iii) It depends upon concentration of non-electrolyte solution.

Hence, (a) and (b) are correct.

**Q. 30** van't Hoff factor ( $i$ ) is given by the expression

$$(a) i = \frac{\text{normal molar mass}}{\text{abnormal molar mass}} \quad (b) i = \frac{\text{abnormal molar mass}}{\text{normal molar mass}}$$

$$(c) i = \frac{\text{observed colligative property}}{\text{calculated colligative property}} \quad (d) i = \frac{\text{calculated colligative property}}{\text{observed colligative property}}$$

**Ans. (a, c)**

van't Hoff factor ( $i$ ) is a measure of extent of association or dissociation of solute particles which can be calculated as

$$i = \frac{\text{normal molar mass}}{\text{abnormal molar mass}} = \frac{\text{observed colligative property}}{\text{calculated colligative property}}$$

**Q. 31** Isotonic solutions must have the same .....

- (a) solute (b) density  
(c) elevation in boiling point (d) depression in freezing point

**Ans. (c, d)**

Isotonic solutions have same osmotic pressure and same concentration. Elevation in boiling point and depression in freezing point are the colligative properties. These two colligative properties depend upon concentration.

As the molar concentration is same for isotonic solutions, so elevation in boiling point and depression in freezing point of isotonic solutions must be same.

**Q. 32** Which of the following binary mixtures will have same composition in liquid and vapour phase?

- (a) Benzene-toluene (b) Water-nitric acid  
(c) Water-ethanol (d)  $n$ -hexane— $n$ -heptane

**Ans. (b, c)**

Mixtures having same composition in liquid and vapour phase are known as azeotropes. Azeotropes boils at same temperature.

Here, water-nitric acid and water-ethanol mixtures are non-ideal solution. Hence, water-nitric acid and water-ethanol are examples of azeotropes.

While benzene-toluene and  $n$ -hexane— $n$ -heptane are examples of ideal solution.

**Q. 33** In isotonic solutions .....

- (a) solute and solvent both are same  
(b) osmotic pressure is same  
(c) solute and solvent may or may not be same  
(d) solute is always same solvent may be different

**Ans. (b, c)**

The two solutions having same osmotic pressure are known as isotonic solutions. The solute and solvent particles may or may not be same but osmotic pressure must be same.

**Q. 34** For a binary ideal liquid solution, the variation in total vapour pressure versus composition of solution is given by which of the curves?

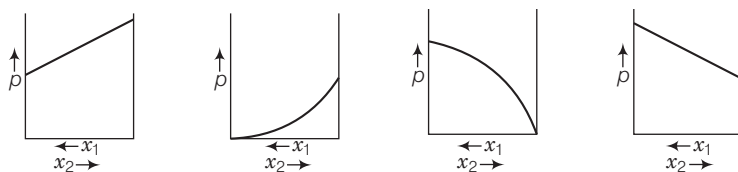

**Ans. (a, d)**

Depending on the vapour pressures of the pure components 1 and 2, total vapour pressure over the solution decreases or increases with the increase of the mole fraction of component 1.

**Q. 35** Colligative properties are observed when .....

- (a) a non-volatile solid is dissolved in a volatile liquid
- (b) a non-volatile liquid is dissolved in another volatile liquid
- (c) a gas is dissolved in non-volatile liquid
- (d) a volatile liquid is dissolved in another volatile liquid

**Ans. (a, b)**

When any of one component of binary mixture either solvent or solute is volatile it causes deviation from ideal behaviour and vapour pressure of solution which causes change in colligative property.

Hence, (a) and (b) are correct.

## Short Answer Type Questions

**Q. 36** Components of a binary mixture of two liquids A and B were being separated by distillation. After some time separation of components stopped and composition of vapour phase became same as that of liquid phase. Both the components started coming in the distillate. Explain why this happened?

**Ans.** Both the components are appearing in the distillate and composition of liquid and vapour is same. This shows that liquids have formed azeotropic mixture and boils at constant temperature hence cannot be separated at this stage by distillation or fractional distillation. Solution having azeotropic nature show large positive or negative deviation from Raoult's law depending upon intermolecular interaction.

**Q. 37** Explain why on addition of 1 mole of NaCl to 1 L of water, the boiling point of water increases, while addition of 1 mole of methyl alcohol to 1 L of water decreases its boiling point.

**Ans.** NaCl is a non-volatile solute. So, its addition to water lowers the vapour pressure of the water. Hence, boiling point of water (solution) increases. Whereas methyl alcohol is more volatile than water.

So, its addition to water increases the total vapour pressure over the solution. It results in the decrease of boiling point.

**Q. 38** Explain the solubility rule “like dissolves like” in terms of intermolecular forces that exist in solutions.

**Ans.** If the intermolecular interactions are similar in both constituents, *i.e.*, solute and solvent then solute dissolves in the solvent. *e.g.*, polar solutes dissolve in polar solvents and non-polar solutes in non-polar solvents.

Thus, the statement ‘like dissolves like’ proves to be true. *e.g.*, organic compounds dissolve in non-polar organic solvent while polar inorganic compounds (salts) dissolve in polar solvent (water).

**Q. 39** Concentration terms such as mass percentage, ppm, mole fraction and molality are independent of temperature, however molarity is a function of temperature. Explain.

**💡 Thinking Process**

*To solve this problem notice the role of temperature in component of concentration term such as volume, mass, number of moles etc.*

**Ans.** Molarity is defined as the number of moles of solute dissolved per litre of a solution. Since, volume depends on temperature and changes with change in temperature, the molarity will also change with change in temperature.

On the other hand, mass does not change with change in temperature, so other concentration terms given in the question also do not do so. Thus, temperature has no effect on the mass but it has significant effect on volume.

**Q. 40** What is the significance of Henry’s law constant  $K_H$ ?

**Ans.** According to Henry’s law  $p \propto x \Rightarrow p = K_H x$

Higher the value of Henry’s law constant  $K_H$ , the lower is the solubility of the gas in a liquid. Thus, the solubility of a gas in the given liquid can be increased by increasing pressure.

**Q. 41** Why are aquatic species more comfortable in cold water in comparison to warm water?

**Ans.** Aquatic species are more comfortable in cold water due to the presence of more oxygen. Solubility of oxygen in water increases with decrease in temperature as solubility of a gas in given liquid decreases with increase in temperature.

**Q. 42 (a)** Explain the following phenomena with the help of Henry’s law.

(i) Painful condition known as bends.

(ii) Feeling of weakness and discomfort in breathing at high altitude.

(b) Why soda water bottle kept at room temperature fizzes on opening?

**Ans. (a)** (i) Henry’s law represents a relation between solubility of gases in liquid and pressure. Scuba drivers when comes towards surface, the pressure gradually decreases. This reduce pressure releases the dissolve gas present in blood and leads to formation of bubbles of nitrogen in the blood.

This creates a painful condition by blocking capillaries known as blends.

(ii) At high altitude atmospheric pressure is low as compared to surface which causes difficulty in breathing. On that condition we feel weakness and discomfort.

(b) Soda water bottle kept at room temperature fizzes on opening due to different pressure inside and outside the bottle. When the bottle is opened to air, the partial pressure of  $\text{CO}_2$  above the solution decreases. As a result, solubility decreases and hence  $\text{CO}_2$  bubbles out.

**Q. 43** Why is the vapour pressure of an aqueous solution of glucose lower than that of water?

**Ans.** In pure liquid, the entire surface of liquid is occupied by the molecules of water. When a non-volatile solute, e.g., glucose is dissolved in water, the fraction of surface covered by the solvent molecules gets reduced because some positions are occupied by glucose molecules.

So, number of solvent molecules escaping from the surface is reduced. That is why vapour pressure of aqueous solution of glucose is reduced.

**Q. 44** How does sprinkling of salt help in clearing the snow covered roads in hilly areas? Explain the phenomenon involved in the process.

**Ans.** When salt is spread over snow covered roads, snow starts melting from the surface because depression of freezing point of water takes place due to addition of salt. It helps in clearing of roads.

Hence, the phenomena is depression in freezing point which helps in clearing the snow covered roads in hilly areas.

**Q. 45** What is “semipermeable membrane”?

**Ans.** Continuous sheets or films (natural or synthetic) which contain a network of submicroscopic holes or pores through which small solvent molecules (water etc.) can pass, but solute molecules of bigger size cannot pass are called semipermeable membrane. e.g., cellophane membrane.

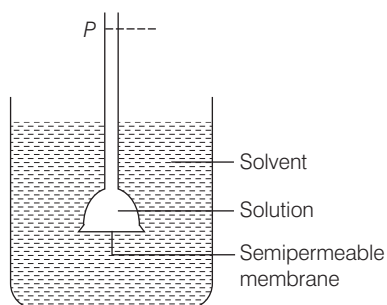

**Q. 46** Give an example of a material used for making semipermeable membrane for carrying out reverse osmosis.

**Ans.** Since pressure required for the reverse osmosis is very high, so, a suitable material is used for making semipermeable membrane. It is generally cellulose acetate placed over suitable support.

## Matching The Columns

**Q. 47** Match the items given in Column I and Column II.

Column I	Column II
A. Saturated solution	1. Solution having same osmotic pressure at a given temperature as that of given solution.
B. Binary solution	2. A solution whose osmotic pressure is less than that of another.
C. Isotonic solution	3. Solution with two components.
D. Hypotonic solution	4. A solution which contains maximum amount of solute that can be dissolved in a given amount of solvent at a given temperature.
E. Solid solution	5. A solution whose osmotic pressure is more than that of another.
F. Hypertonic solution	6. A solution in solid phase.

**Ans. A.** → (4)   **B.** → (3)   **C.** → (1)   **D.** → (2)   **E.** → (6)   **F.** → (5)

- A. Saturated solution** A solution which contains maximum amounts of solute that can be dissolved in a given amount of solvent at a given temperature.
- B. Binary solution** A solution with two components is known as binary solution.
- C. Isotonic solution** A solution having same osmotic pressure at a given temperature as that of given solution is known as isotonic solution.
- D. Hypotonic solution** A solution whose osmotic pressure is less than another is known as hypotonic solution.
- E. Solid solution** A solution in solid phase is known as solid solution.
- F. Hypertonic solution** A solution whose osmotic pressure is greater than that of another is known as hypertonic solution.

**Q. 48** Match the items given in Column I with the type of solutions given in Column II.

Column I	Column II
A. Soda water	1. A solution of gas in solid
B. Sugar solution	2. A solution of gas in gas
C. German silver	3. A solution of solid in liquid
D. Air	4. A solution of solid in solid
E. Hydrogen gas in palladium	5. A solution of gas in liquid
	6. A solution of liquid in solid

**Ans. A.** → (5)   **B.** → (3)   **C.** → (4)   **D.** → (2)   **E.** → (1)

- A. Soda water** A solution of gas in liquid. e.g.,  $\text{CO}_2$  in soft drinks.
- B. Sugar solution** A solution of solid in liquid in which sugar particles (solid) are dissolved in water (liquid).
- C. German silver** German silver is an alloy which is a solid solution of solid in solid. It is an alloy of Cu, Zn and Ni.
- D. Air** A solution of gas in gas. Air is a mixture of various gases.
- E. Hydrogen gas in palladium** is an example of solution of gas in solid. This is used as an reducing agent.

**Q. 49** Match the laws given in Column I with expressions given in Column II.

Column I	Column II
A. Raoult's law	1. $\Delta T_f = K_f m$
B. Henry's law	2. $\pi = CRT$
C. Elevation of boiling point	3. $p = x_1 p_1^0 + x_2 p_2^0$
D. Depression in freezing point	4. $\Delta T_b = K_b m$
E. Osmotic pressure	5. $p = K_H \cdot x$

**Ans.** A.  $\rightarrow$  (3) B.  $\rightarrow$  (5) C.  $\rightarrow$  (1) D.  $\rightarrow$  (4) E.  $\rightarrow$  (2)

A. **Raoult's law** Mathematical representation of Raoult's law

$$p = x_1 p_1^0 + x_2 p_2^0$$

B. **Henry's law**  $p = K_H \cdot x$

C. **Elevation of boiling point** Mathematical representation,  $\Delta T_b = K_b \cdot m$

D. **Depression in freezing point** Mathematical representation,  $\Delta T_f = K_f \cdot m$

E. **Osmotic pressure** Mathematical representation,  $\pi = CRT$ .

**Q. 50** Match the terms given in Column I with expressions given in Column II.

Column I	Column II
A. Mass percentage	1. $\frac{\text{Number of moles of the solute component}}{\text{Volume of solution in litres}}$
B. Volume percentage	2. $\frac{\text{Number of moles of a component}}{\text{Total number of moles of all the components}}$
C. Mole fraction	3. $\frac{\text{Volume of the solute component in solution}}{\text{Total volume of solution}} \times 100$
D. Molality	4. $\frac{\text{Mass of the solute component in solution}}{\text{Total mass of the solution}} \times 100$
E. Molarity	5. $\frac{\text{Number of moles of the solute components}}{\text{Mass of solvent in kilograms}}$

**Ans.** A.  $\rightarrow$  (4) B.  $\rightarrow$  (3) C.  $\rightarrow$  (2) D.  $\rightarrow$  (5) E.  $\rightarrow$  (1)

Column I (Concentration terms)	Column II (Mathematical formula)
A. Mass percentage	$\frac{\text{Mass of the solute component in solution}}{\text{Total mass of the solution}} \times 100$
B. Volume percentage	$\frac{\text{Volume of the solute component in solution}}{\text{Total volume of solution}} \times 100$
C. Mole fraction	$\frac{\text{Number of moles of a component}}{\text{Total number of moles of all the components}}$
D. Molality	$\frac{\text{Number of moles of the solute components}}{\text{Mass of solvent in kilograms}}$
E. Molarity	$\frac{\text{Number of moles of the solute component}}{\text{Volume of solution in litres}}$

## Assertion and Reason

*In the following questions a statement of assertion (A) followed by a statement of reason (R) is given. Choose the correct answer out of the following choices.*

- (a) Assertion and reason both are correct statements and reason is correct explanation for assertion.
- (b) Assertion and reason both are correct statements but reason is not correct explanation for assertion.
- (c) Assertion is correct statement but reason is wrong statement.
- (d) Assertion and reason both are incorrect statements.
- (e) Assertion is wrong statement but reason is correct statement.

**Q. 51** Assertion (A) Molarity of a solution in liquid state changes with temperature.

Reason (R) The volume of a solution changes with change in temperature.

**Ans. (a)** Assertion and reason both are correct statements and reason is the correct explanation of assertion.

Volume of solutions is a function of temperature which varies with temperature. Hence, molarity of solution in liquid state changes with temperature.

$$\text{Molarity} = \frac{\text{moles of solute}}{\text{volume of solution in litre}}$$

**Q. 52** Assertion (A) When methyl alcohol is added to water, boiling point of water increases.

Reason (R) When a volatile solute is added to a volatile solvent elevation in boiling point is observed.

**Ans. (d)** Assertion is wrong statement but reason is correct statement.

When methyl alcohol is added to water, boiling point of water decreases because when a volatile solute is added to a volatile solvent elevation in boiling point is observed.

**Q. 53** Assertion (A) When NaCl is added to water a depression in freezing point is observed.

Reason (R) The lowering of vapour pressure of a solution causes depression in the freezing point.

**Ans. (a)** Assertion and reason both are correct and reason is correct explanation of assertion. When NaCl is added to water a depression in freezing point is observed. This is due to lowering of vapour pressure of a solution. Lowering of vapour pressure is observed due to intermolecular interaction of solvent-solute particles.



**Q. 54** Assertion (A) When a solution is separated from the pure solvent by a semipermeable membrane, the solvent molecules pass through it from pure solvent side to the solution side.

Reason (R) Diffusion of solvent occurs from a region of high concentration solution to a region of low concentration solution.

**Ans. (b)** Assertion and reason both are correct statements but reason is not the correct explanation of assertion.

When a solution is separated from the pure solvent by a semipermeable membrane, the solvent molecules pass through it from pure solvent side to the solution side. Solvent molecules always flow from lower concentration to higher concentration of solution.

## Long Answer Type Questions

**Q. 55** Define the following modes of expressing the concentration of a solution? Which of these modes are independent of temperature and why?

- |                                     |                             |
|-------------------------------------|-----------------------------|
| (a) w/w (mass percentage)           | (b) V/V (volume percentage) |
| (c) w/V (mass by volume percentage) | (d) ppm (parts per million) |
| (e) $\chi$ (mole fraction)          | (f) M (molarity)            |
| (g) m (molality)                    |                             |

**Ans. (a)** **w/w** (mass percentage) Mass percentage of a component of a solution can be expressed as

$$\text{Mass \% of component} = \frac{\text{mass of component in the solution}}{\text{total mass of solution}} \times 100$$

Thus, the percentage by mass means the mass of the solute in grams present in 100g of the solution.

(b) **V/V** (volume percentage) is defined as

$$\text{Volume percentage} = \frac{\text{volume of the component}}{\text{total volume of solution}} \times 100$$

Thus, volume percentage means the volume of the liquid solute in  $\text{cm}^3$  present in  $100 \text{ cm}^3$  of the solution.

(c) **w/V** (mass by volume percentage) = mass of solute dissolved in 100 mL of solution.

(d) **ppm** (parts per million) This parameter is used to express the concentration of very dilute solution.

$$\text{ppm} = \frac{\text{number of parts of component}}{\text{total number of parts of all component of solution}} \times 10^6$$

(e)  $\chi$  (mole fraction) Mole fraction is an unitless quantity used to determine extent of any particular component present in total solution.

$$\chi = \frac{\text{number of moles of the component}}{\text{total number of moles of all components}}$$

- (f) **M** (molarity) Number of moles of solute dissolved in per litre of solution is known as molarity.

$$M = \frac{\text{number of moles of solute}}{\text{volume of solution in litre}}$$

- (g) **m** (Molality) Molality of any solution can be defined as number of moles of solute dissolved in per kg of solvent.

$$m = \frac{\text{number of moles of solute}}{\text{mass of solvent in kg}}$$

**Q. 56** Using Raoult's law explain how the total vapour pressure over the solution is related to mole fraction of components in the following solutions.

- (a)  $\text{CHCl}_3$  (l) and  $\text{CH}_2\text{Cl}_2$  (l)      (b)  $\text{NaCl}$ (s) and  $\text{H}_2\text{O}$  (l)

**Ans.** According to Raoult's law for any solution the partial vapour pressure of each volatile component in the solution is directly proportional to its mole fraction.

$$p_1 = p_1^\circ x_1$$

- (a)  $\text{CHCl}_3$  (l) and  $\text{CH}_2\text{Cl}_2$  (l) both are volatile components.

Hence, for a binary solution in which both components are volatile liquids, the total pressure will be

$$\begin{aligned} p &= p_1 + p_2 = x_1 p_1^\circ + x_2 p_2^\circ \\ &= x_1 p_1^\circ + (1 - x_1) p_2^\circ = (p_1^\circ - p_2^\circ) x_1 + p_2^\circ \end{aligned}$$

where,  $p$  = total vapour pressure

$p_1$  = partial vapour pressure of component 1

$p_2$  = partial vapour pressure of component 2

- (b)  $\text{NaCl}$  (s) and  $\text{H}_2\text{O}$ (l) both are non-volatile components.

Hence, for a solution containing non-volatile solute, the Raoult's law is applicable only to vaporisable component and total vapour pressure can be written as

$$p = p_1 = x_1 p_1^\circ$$

**Q. 57** Explain the terms ideal and non-ideal solutions in the light of forces of interactions operating between molecules in liquid solutions.

**Ans.** The solutions which obey Raoult's law over the entire range of concentration are known as ideal solutions. For an ideal solution  $\Delta V_{\text{mix}} = 0$  and  $\Delta H_{\text{mix}} = 0$ . The ideal behaviour of the solutions can be explained by considering two components A and B.

In pure components, the intermolecular attractive interactions will be of A—A type and B—B type, whereas in the binary solutions in addition to these two, A—B type of interaction will also be present. If A—A and B—B intermolecular forces are nearly equal to those between A—B, this leads to the formation of ideal solution e.g., solution of *n*-hexane and *n*-heptane.

When a solution does not obey-Raoult's law over the entire range of concentration, then it is called non-ideal solution. The vapour pressure of such a solution is either higher or lower, than that predicted by Raoult's law.

If it is higher, the solution exhibits positive deviation and if it is lower it exhibits negative deviation from Raoult's law. In case of positive deviation, A—B interactions are weaker than those between A—A or B—B. i.e., the attractive forces between solute solvent molecules are weaker than those between solute-solute and solvent-solvent molecules e.g., mixture of ethanol and acetone.

For such solutions  $\Delta H_{\text{mixing}} = + \text{ve}$  and  $\Delta V_{\text{mixing}} = + \text{ve}$

On the other hand, in case of negative deviation the intermolecular attractive forces between A—A and B—B are weaker than those between A—B molecules. Thus, the escaping tendency of A and B types of molecules from the solution becomes less than from the pure liquids i.e., mixture of chloroform and acetone.

For such solution

$$\Delta H_{\text{mix}} = - \text{ve and } \Delta V_{\text{mix}} = - \text{ve}$$

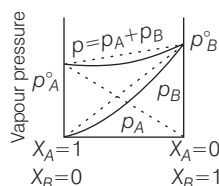
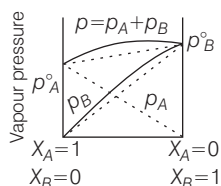
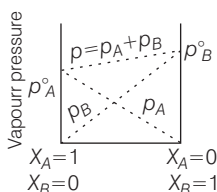

Graph for ideal solution

Graph showing +ve deviation

Graph showing -ve deviation

**Q. 58** Why is it not possible to obtain pure ethanol by fractional distillation? What general name is given to binary mixtures which show deviation from Raoult's law and whose components cannot be separated by fractional distillation. How many types of such mixtures are there?

**Ans.** The solution or mixture having same composition in liquid as well as in vapour phase and boils at a constant temperature is known as azeotropes. Due to constant composition it can't be separated by fractional distillation. *There are two types of azeotropes*

- Minimum boiling azeotropes** Solutions which show large positive deviation from Raoult's law form minimum boiling azeotropes at a specific composition. e.g., ethanol—water mixture
- Maximum boiling azeotropes** Solutions which show large negative deviation from Raoult's law form maximum boiling azeotropes. e.g., solution having composition 68%  $\text{HNO}_3$  and 32% water by mass.

**Q. 59** When kept in water, raisin swells in size. Name and explain the phenomenon involved with the help of a diagram. Give three applications of the phenomenon.

**Ans.** This phenomenon is called endo osmosis, i.e., movement of water inside the raisin and shown with the help of diagram as

The process of osmosis is of immense biological as well as industrial important. *It is evident from the following examples.*

- Movement of water from soil into plant roots and subsequently into upper portion of the plant is partly due to osmosis.
- Preservation of meat against bacterial action by addition of salt.
- Preservation of fruits against bacterial action by adding sugar. Bacterium in canned fruit loses water through the process of osmosis and become inactive.
- Reverse-osmosis is used in desalination of water.

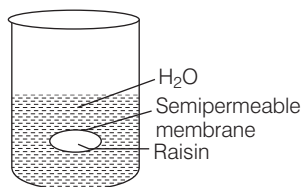

**Q. 60** Discuss biological and industrial applications of osmosis.

**Ans.**

- In animals, water moves into different parts of the body under the effect of the process of osmosis.
- Stretching of leaves, flower, etc., is also controlled by osmosis.
- Osmosis helps in rapid growth of the plants and germination of seeds.
- Different movements of plants such as opening and closing of flowers etc, are controlled by osmosis.

**Q. 61** How can you remove the hard calcium carbonate layer of the egg without damaging its semipermeable membrane? Can this egg be inserted into a bottle with a narrow neck without distorting its shape? Explain the process involved.

**Thinking Process**

*The question can be answered using the concept of solubility, osmosis, reverse-osmosis, hypertonic solution and hypotonic solution.*

**Ans.** When egg is placed in mineral acid solution outershell of egg dissolves. Egg is now removed and placed in hypertonic solution. Size of egg get reduced and egg shrivels due to osmosis. Egg is now placed in a bottle with narrow neck. Finally on adding hypotonic solution egg regain its shape due to osmosis.

*Diagrammatically it can be represented as*

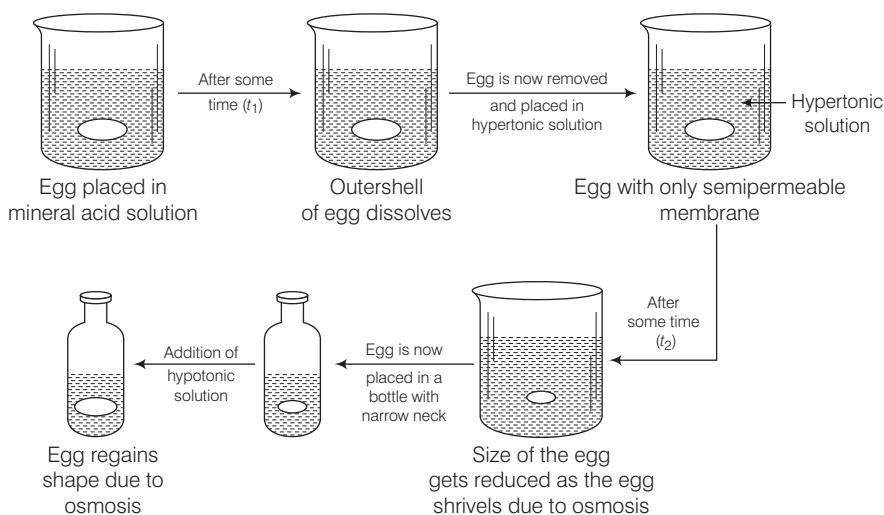

**Q. 62** Why is the mass determined by measuring a colligative property in case of some solutes abnormal? Discuss it with the help of van't Hoff factor.

**Ans.** Certain compounds when dissolved in suitable solvents either dissociate or associate. e.g., ethanoic acid dimerises in benzene due to H-bonding, while in water, it dissociates and forms ions.

As a result the number of chemical species in solution increases or decreases as compared to the number of chemical species of solute added to form the solution.

Since, the magnitude of colligative property depends on the number of solute particles, it is expected that the molar mass determined on the basis of colligative properties will either higher or lower than the expected value or the normal value and is called abnormal molar mass.

In order to account for the extent of dissociation or association of molecules in solution, van't Hoff introduced a factor,  $i$ , known as the van't Hoff factor.

$$i = \frac{\text{expected molar mass}}{\text{abnormal molar mass}} = \frac{\text{observed colligative property}}{\text{calculated colligative property}}$$

$$= \frac{\text{total number of moles of particles after association or dissociation}}{\text{total number of moles of particles before association or dissociation}}$$

# Electrochemistry

## Multiple Choice Questions (MCQs)

**Q. 1** Which cell will measure standard electrode potential of copper electrode?

- (a)  $\text{Pt (s)} \mid \text{H}_2(\text{g}, 0.1 \text{ bar}) \mid \text{H}^+(\text{aq}, 1 \text{ M}) \parallel \text{Cu}^{2+}(\text{aq}, 1 \text{ M}) \mid \text{Cu}$   
 (b)  $\text{Pt (s)} \mid \text{H}_2(\text{g}, 1 \text{ bar}) \mid \text{H}^+(\text{aq}, 1 \text{ M}) \parallel \text{Cu}^{2+}(\text{aq}, 2 \text{ M}) \mid \text{Cu}$   
 (c)  $\text{Pt (s)} \mid \text{H}_2(\text{g}, 1 \text{ bar}) \mid \text{H}^+(\text{aq}, 1 \text{ M}) \parallel \text{Cu}^{2+}(\text{aq}, 1 \text{ M}) \mid \text{Cu}$   
 (d)  $\text{Pt (s)} \mid \text{H}_2(\text{g}, 0.1 \text{ bar}) \mid \text{H}^+(\text{aq}, 0.1 \text{ M}) \parallel \text{Cu}^{2+}(\text{aq}, 1 \text{ M}) \mid \text{Cu}$

**Ans. (c)** Standard electrode potential of copper electrode can be calculated by constructing a concentration cell composed of two half cell reactions in which concentration of species on left hand and right hand side are unity. In such case cell potential is equal to standard electrode potential.

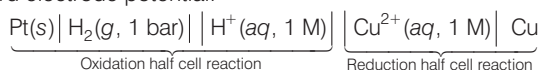

**Q. 2** Electrode potential for Mg electrode varies according to the equation

$$E_{\text{Mg}^{2+}/\text{Mg}} = E_{\text{Mg}^{2+}/\text{Mg}}^s - \frac{0.059}{2} \log \frac{1}{[\text{Mg}^{2+}]}$$

vs  $\log [\text{Mg}^{2+}]$  is

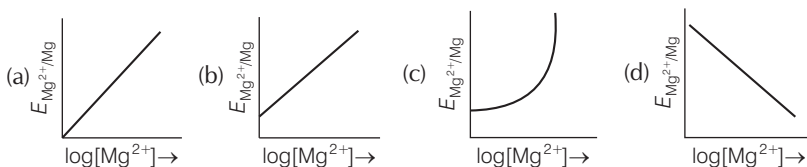

### Thinking Process

This problem includes concept of Nernst equation and its transformation to equation of straight line.

**Ans.** Electrode potential for Mg electrode varies according to the equation

$$E_{\text{Mg}^{2+}/\text{Mg}} = E_{\text{Mg}^{2+}/\text{Mg}}^{\circ} - \frac{0.059}{2} \log \frac{1}{[\text{Mg}^{2+}]}$$

$$E_{\text{Mg}^{2+}/\text{Mg}} = E_{\text{Mg}^{2+}/\text{Mg}}^{\circ} + \frac{0.059}{2} \log [\text{Mg}^{2+}]$$

$$E_{\text{Mg}^{2+}/\text{Mg}} = \frac{0.059}{2} \log [\text{Mg}^{2+}] + E_{\text{Mg}^{2+}/\text{Mg}}^{\circ}$$

This equation represents equation of straight line. It can be correlated as

$$E_{\text{Mg}^{2+}/\text{Mg}} = \left( \frac{0.059}{2} \right) \log [\text{Mg}^{2+}] + E_{\text{Mg}^{2+}/\text{Mg}}^{\circ}$$

$\uparrow$                      $\uparrow$                      $\uparrow$                      $\uparrow$   
 Y                    M                    X                    + C

So, intercept (C) =  $E_{\text{Mg}^{2+}/\text{Mg}}^{\circ}$

Thus, equation can be diagrammatically represented as

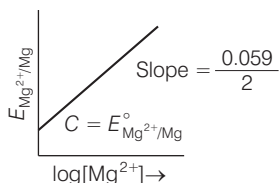

**Q. 3** Which of the following statement is correct?

- (a)  $E_{\text{cell}}$  and  $\Delta_r G$  of cell reaction both are extensive properties
- (b)  $E_{\text{cell}}$  and  $\Delta_r G$  of cell reaction both are intensive properties
- (c)  $E_{\text{cell}}$  is an intensive property while  $\Delta_r G$  of cell reaction is an extensive property
- (d)  $E_{\text{cell}}$  is an extensive property while  $\Delta_r G$  of cell reaction is an intensive property

**💡 Thinking Process**

*This problem is based on thermodynamical concept of intensive and extensive property. During answering this question must keep in mind that intensive property is independent on number of particles and extensive property is dependent on number of particles.*

**Ans. (c)**  $E_{\text{cell}}$  is an intensive property as it does not depend upon mass of species (number of particles) but  $\Delta_r G$  of the cell reaction is an extensive property because this depends upon mass of species (number of particles).

**Q. 4** The difference between the electrode potentials of two electrodes when no current is drawn through the cell is called.....

- (a) cell potential
- (b) cell emf
- (c) potential difference
- (d) cell voltage

**Ans. (b) Cell emf** The difference between the electrode potential of two electrodes when no current is drawn through the cell is called cell emf.

**Q. 5** Which of the following statement is not correct about an inert electrode in a cell?

- (a) It does not participate in the cell reaction
- (b) It provides surface either for oxidation or for reduction reaction
- (c) It provides surface for conduction of electrons
- (d) It provides surface for redox reaction

**Ans. (d)** An inert electrode in a cell provide surface for either oxidation or for reduction reaction by conduction of electrons through its surface but does not participate in the cell reaction.

It does not provide surface for redox reaction.

**Q. 6** An electrochemical cell can behave like an electrolytic cell when .....

- (a)  $E_{\text{cell}} = 0$  (b)  $E_{\text{cell}} > E_{\text{ext}}$   
 (c)  $E_{\text{ext}} > E_{\text{cell}}$  (d)  $E_{\text{cell}} = E_{\text{ext}}$

**Ans. (c)** If an external opposite potential is applied on the galvanic cell and increased reaction continues to take place till the opposing voltage reaches the value 1.1 V.

At this stage no current flow through the cell and if there is any further increase in the external potential then reaction starts functioning in opposite direction.

Hence, this works as an electrolytic cell.

**Q. 7** Which of the statements about solutions of electrolytes is not correct?

- (a) Conductivity of solution depends upon size of ions  
 (b) Conductivity depends upon viscosity of solution  
 (c) Conductivity does not depend upon solvation of ions present in solution  
 (d) Conductivity of solution increases with temperature

**Ans. (c)** Solution consists of electrolytes is known as electrolytic solution and conductivity of electrolytic solution depends upon the following factors

- (i) **Size of ions** As ion size increases, ion mobility decreases and conductivity decreases.  
 (ii) **Viscosity of solution** Greater the viscosity of the solvent lesser will be the conductivity of the solution.  
 (iii) **Solvation of ions** Greater the solvation of ions of an electrolyte lesser will be the electrical conductivity of the solution.  
 (iv) **Temperature of medium** Conductivity of solution increases with increase in temperature.

**Q. 8** Using the data given below find out the strongest reducing agent.

$$E^{\circ}_{\text{Cr}_2\text{O}_7^{2-}/\text{Cr}^{3+}} = 1.33\text{V}; E^{\circ}_{\text{Cl}_2/\text{Cl}^-} = 1.36\text{V}$$

$$E^{\circ}_{\text{MnO}_4^-/\text{Mn}^{2+}} = 1.51\text{V}; E^{\circ}_{\text{Cr}^{3+}/\text{Cr}} = -0.74\text{V}$$

- (a)  $\text{Cl}^-$  (b) Cr (c)  $\text{Cr}^{3+}$  (d)  $\text{Mn}^{2+}$

**Thinking Process**

*This problem includes concept of electrochemical series and standard reduction potential of the metal.*

*Higher the negative value of standard reduction potential, strongest will be the reducing agent.*

*As value of SRP increases from negative to positive value nature of species changes from reducing to oxidising nature.*

**Ans. (b)** Here, out of given four options standard reduction potential of chromium has highest negative value hence most powerful reducing agent is chromium.

**Q. 9** Use the data given in Q. 8 and find out which of the following is the strongest oxidising agent?

- (a)  $\text{Cl}^-$  (b)  $\text{Mn}^{2+}$   
(c)  $\text{MnO}_4^-$  (d)  $\text{Cr}^{3+}$

**Ans. (c)** Higher the positive value of standard reduction potential of metal ion higher will be its oxidising capacity.

Since,  $E_{\text{MnO}_4^-/\text{Mn}^{2+}}^\circ$  has value equal to 1.51 V hence it is the strongest oxidising agent.

**Q. 10** Using the data given in Q.8 find out in which option the order of reducing power is correct.

- (a)  $\text{Cr}^{3+} < \text{Cl}^- < \text{Mn}^{2+} < \text{Cr}$  (b)  $\text{Mn}^{2+} < \text{Cl}^- < \text{Cr}^{3+} < \text{Cr}$   
(c)  $\text{Cr}^{3+} < \text{Cl}^- < \text{Cr}_2\text{O}_7^{2-} < \text{MnO}_4^-$  (d)  $\text{Mn}^{2+} < \text{Cr}^{3+} < \text{Cl}^- < \text{Cr}$

**Ans. (b)**

Species (ions)	SRP values
$\text{Mn}^{2+}$	1.51 V
$\text{Cl}^-$	1.36 V
$\text{Cr}^{3+}$	1.33 V
Cr	-0.74 V

On moving top to bottom SRP value decreases from positive to negative value which will increase the reducing capacity. So, the correct option is (b).

**Q. 11** Use the data given in Q. 8 and find out the most stable ion in its reduced form.

- (a)  $\text{Cl}^-$  (b)  $\text{Cr}^{3+}$  (c) Cr (d)  $\text{Mn}^{2+}$

**Ans. (d)**  $E_{\text{MnO}_4^-/\text{Mn}^{2+}}^\circ$  has +ve value equal to 1.51 V which is highest among given four choices. So,  $\text{Mn}^{2+}$  is most stable ion in its reduced form.

**Q. 12** Use the data of Q. 8 and find out the most stable oxidised species.

- (a)  $\text{Cr}^{3+}$  (b)  $\text{MnO}_4^-$  (c)  $\text{Cr}_2\text{O}_7^{2-}$  (d)  $\text{Mn}^{2+}$

**Ans. (a)**  $E_{\text{Cr}^{3+}/\text{Cr}}^\circ$  has most -ve value equal to -0.74 among given four choices. So,  $\text{Cr}^{3+}$  is the most stable oxidised species.

**Q. 13** The quantity of charge required to obtain one mole of aluminium from  $\text{Al}_2\text{O}_3$  is .....

- (a) 1 F (b) 6 F (c) 3 F (d) 2 F

**Ans. (c)** The quantity of charge required to obtain one mole of aluminium from  $\text{Al}_2\text{O}_3$  is equal to number of electron required to convert  $\text{Al}_2\text{O}_3$  to Al.

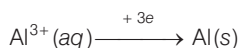

Hence, total 3F is required.



**Q. 14** The cell constant of a conductivity cell .....

- (a) changes with change of electrolyte  
 (b) changes with change of concentration of electrolyte  
 (c) changes with temperature of electrolyte  
 (d) remains constant for a cell

**Ans. (d)** Cell constant is defined as the ratio of length of object and area of cross section.

$$G = \frac{l}{A}$$

Since,  $l$  and  $A$  remain constant for any particular object hence value of cell constant always remains constant.

**Q. 15** While charging the lead storage battery .....

- (a)  $\text{PbSO}_4$  anode is reduced to Pb (b)  $\text{PbSO}_4$  cathode is reduced to Pb  
 (c)  $\text{PbSO}_4$  cathode is oxidised to Pb (d)  $\text{PbSO}_4$  anode is oxidised to  $\text{PbO}_2$

**Ans. (a)** While charging the lead storage battery the reaction occurring on cell is reversed and  $\text{PbSO}_4$  (s) on anode and cathode is converted into Pb and  $\text{PbO}_2$  respectively

Hence, option (a) is the correct choice

The electrode reactions are as follows

**At cathode**  $\text{PbSO}_4(\text{s}) + 2\text{e}^- \rightarrow \text{Pb}(\text{s}) + \text{SO}_4^{2-}(\text{aq})$  (Reduction)

**At anode**  $\text{PbSO}_4(\text{s}) + 2\text{H}_2\text{O} \rightarrow \text{PbO}_2(\text{s}) + \text{SO}_4^{2-} + 4\text{H}^+ + 2\text{e}^-$  (Oxidation)

**Overall reaction**  $2\text{PbSO}_4(\text{s}) + 2\text{H}_2\text{O} \rightarrow \text{Pb}(\text{s}) + \text{PbO}_2(\text{s}) + 4\text{H}^+(\text{aq.}) + 2\text{SO}_4^{2-}(\text{aq.})$

**Q. 16**  $\Lambda_m^\circ(\text{NH}_4\text{OH})$  is equal to .....

- (a)  $\Lambda_m^\circ(\text{NH}_4\text{OH}) + \Lambda_m^\circ(\text{NH}_4\text{Cl}) - \Lambda_m^\circ(\text{HCl})$  (b)  $\Lambda_m^\circ(\text{NH}_4\text{Cl}) + \Lambda_m^\circ(\text{NaOH}) - \Lambda_m^\circ(\text{NaCl})$   
 (c)  $\Lambda_m^\circ(\text{NH}_4\text{Cl}) + \Lambda_m^\circ(\text{NaCl}) - \Lambda_m^\circ(\text{NaOH})$  (d)  $\Lambda_m^\circ(\text{NaOH}) + \Lambda_m^\circ(\text{NaCl}) - \Lambda_m^\circ(\text{NH}_4\text{Cl})$

### Thinking Process

This question is based on the concept of Kohlrausch law and can be solved by using the concept involved in calculation of limiting molar conductivity of any salt. According to Kohlrausch law limiting molar conductivity of any salt is equal to sum of limiting molar conductivity of individual molar conductivity of cations and anions of electrolyte.

**Ans. (b)**

$$\Lambda_m^\circ(\text{NH}_4\text{Cl}) = \Lambda_m^\circ(\text{NH}_4^+) + \Lambda_m^\circ(\text{Cl}^-)$$

$$\Lambda_m^\circ(\text{NaOH}) = \Lambda_m^\circ(\text{Na}^+) + \Lambda_m^\circ(\text{OH}^-)$$

$$\Lambda_m^\circ(\text{NaCl}) = \Lambda_m^\circ(\text{Na}^+) + \Lambda_m^\circ(\text{Cl}^-)$$

$$\Lambda_m^\circ(\text{NH}_4\text{Cl}) + \Lambda_m^\circ(\text{NaOH}) - \Lambda_m^\circ(\text{NaCl}) = \Lambda_m^\circ(\text{NH}_4\text{OH})$$

Hence, option (b) is correct choice.

**Q. 17** In the electrolysis of aqueous sodium chloride solution which of the half cell reaction will occur at anode?

- (a)  $\text{Na}^+(\text{aq}) + \text{e}^- \rightarrow \text{Na}(\text{s}); E_{\text{cell}}^{\text{s}} = -2.71 \text{ V}$   
 (b)  $2\text{H}_2\text{O}(\text{l}) \rightarrow \text{O}_2(\text{g}) + 4\text{H}^+(\text{aq}) + 4\text{e}^-; E_{\text{cell}}^{\text{s}} = -1.23 \text{ V}$   
 (c)  $\text{H}^+(\text{aq}) + \text{e}^- \rightarrow \frac{1}{2} \text{H}_2(\text{g}); E_{\text{cell}}^- = 0.00 \text{ V}$   
 (d)  $\text{Cl}^-(\text{aq}) \rightarrow \frac{1}{2} \text{Cl}_2(\text{g}) + \text{e}^-; E_{\text{cell}}^{\text{s}} = 1.36 \text{ V}$

**Ans. (d)** In case of electrolysis of aqueous NaCl oxidation reaction occurs at anode as follows

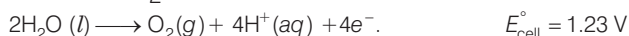
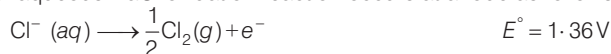

But due to lower  $E_{\text{cell}}^\circ$  value water should get oxidised in preference of  $\text{Cl}^- (\text{aq})$ .

However, the actual reaction taking place in the concentrated solution of NaCl is (d) and not (b) *i.e.*,  $\text{Cl}_2$  is produced and not  $\text{O}_2$ .

This unexpected result is explained on the basis of the concept of 'overvoltage', *i.e.*, water needs greater voltage for oxidation to  $\text{O}_2$  (as it is kinetically slow process) than that needed for oxidation of  $\text{Cl}^-$  ions to  $\text{Cl}_2$ . Thus, the correct option is (d) not (b).

## Multiple Choice Questions (More Than One Options)

**Q. 18** The positive value of the standard electrode potential of  $\text{Cu}^{2+} / \text{Cu}$  indicates that.....

- (a) this redox couple is a stronger reducing agent than the  $\text{H}^+ / \text{H}_2$  couple
- (b) this redox couple is a stronger oxidising agent than  $\text{H}^+ / \text{H}_2$
- (c) Cu can displace  $\text{H}_2$  from acid
- (d) Cu cannot displace  $\text{H}_2$  from acid

**Ans. (b, d)**

'Lesser the  $E^\circ$  value of redox couple higher the reducing power'



Since,  $2\text{H}^+ / \text{H}_2$  has lesser SRP than  $\text{Cu}^{2+} / \text{Cu}$  redox couple. Therefore,

- (i) This redox couple is a stronger oxidising agent than  $\text{H}^+ / \text{H}_2$ .
- (ii) Cu can't displace  $\text{H}_2$  from acid.

Hence, (b) and (d) are correct.

**Q. 19**  $E_{\text{cell}}^s$  for some half cell reactions are given below. On the basis of these mark the correct answer.

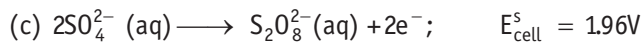
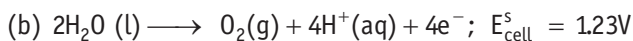
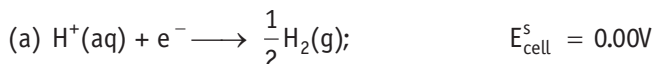

- (a) In dilute sulphuric acid solution, hydrogen will be reduced at cathode
- (b) In concentrated sulphuric acid solution, water will be oxidised at anode
- (c) In dilute sulphuric acid solution, water will be oxidised at anode
- (d) In dilute sulphuric acid solution,  $\text{SO}_4^{2-}$  ion will be oxidised to tetrathionate ion at anode

**Ans. (a, c)**

During the electrolysis of dilute sulphuric acid above given three reaction occurs each of which represents particular reaction either oxidation half cell reaction or reduction half cell reaction.

Oxidation half cell reactions occur at anode are as follows

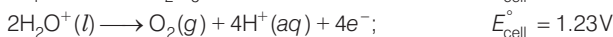

Reaction having lower value of  $E_{\text{cell}}^\circ$  will undergo faster oxidation.

Hence, oxidation of water occur preferentially reduction half cell reaction occurs at cathode

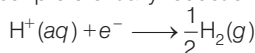

At cathode

Hence, options (a) and (b) are correct.

**Q. 20**  $E_{\text{cell}}^\circ = 1.1\text{V}$  or Daniel cell. Which of the following expressions are correct description of state of equilibrium in this cell?

(a)  $1.1 = K_C$

(b)  $\frac{2.303RT}{2F} \log K_C = 1.1$

(c)  $\log K_C = \frac{2.2}{0.059}$

(d)  $\log K_C = 1.1$

**Ans. (b, c)**

At state of equilibrium

$$\begin{aligned} \Delta G &= -RT \log K \\ -nFE^\circ &= -RT 2.303 \log K_C \\ E^\circ &= \frac{+RT 2.303 \log K_C}{+2F} \end{aligned} \quad (n = 2 \text{ for Daniel cell})$$

$\therefore$  At equilibrium  $E^\circ = 1.1$

$$\therefore \frac{2.303RT}{2F} \log K_C = 1.1$$

$$\log K_C = \frac{2.2}{0.059} \quad [\text{on solving}]$$

Hence, options (b) and (c) are the correct choices.

**Q. 21** Conductivity of an electrolytic solution depends on

- (a) nature of electrolyte
- (b) concentration of electrolyte
- (c) power of AC source
- (d) distance between the electrodes

**Ans. (a, b)**

Conductivity of electrolytic solution is due to presence of mobile ions in the solution. This type of conductance is known as ionic conductance. Conductivity of these type of solutions depend upon

- (i) the nature of electrolyte added
- (ii) size of the ion produced and their solvation
- (iii) concentration of electrolyte
- (iv) nature of solvent and its viscosity
- (v) temperature

While power of source or distance between electrodes has no effect on conductivity of electrolyte solution.

Hence, options (a) and (b) are the correct choices.

Q. 22  $\Lambda_m^\circ \text{H}_2\text{O}$  is equal to.....

- (a)  $\Lambda_m^\circ(\text{HCl}) + \Lambda_m^\circ(\text{NaOH}) - \Lambda_m^\circ(\text{NaCl})$       (b)  $\Lambda_m^\circ(\text{HNO}_3) + \Lambda_m^\circ(\text{NaNO}_3) - \Lambda_m^\circ(\text{NaOH})$   
 (c)  $\Lambda_m^\circ(\text{HNO}_3) + \Lambda_m^\circ(\text{NaOH}) - \Lambda_m^\circ(\text{NaNO}_3)$       (d)  $\Lambda_m^\circ(\text{NH}_4\text{OH}) + \Lambda_m^\circ(\text{HCl}) - \Lambda_m^\circ(\text{NH}_4\text{Cl})$

**Thinking Process**

This problem includes concept of Kohlrausch law and its application in determination of molar conductivity of species. This problem can be solved by following three steps.

- (i) Write the molar conductance of each species in terms of sum of their constituent ions.  
 (ii) Now operate the equation of each option given above by using information provided in the question.  
 (iii) At last if the sum of molar conductivity remaining constituent ions is equal to the molar conductivity of species asked (here  $\Lambda_m^\circ(\text{H}_2\text{O})$ ) then that will be the correct choice.

Ans. (a, c)

(a)

$$\begin{aligned} \Lambda_m^\circ(\text{HCl}) &= \Lambda_m^\circ(\text{H}^+) + \Lambda_m^\circ(\text{Cl}^-) \\ \Lambda_m^\circ(\text{NaOH}) &= \Lambda_m^\circ(\text{Na}^+) + \Lambda_m^\circ(\text{OH}^-) \\ \Lambda_m^\circ(\text{NaCl}) &= \Lambda_m^\circ(\text{Na}^+) + \Lambda_m^\circ(\text{Cl}^-) \\ \hline \Lambda_m^\circ(\text{HCl}) + \Lambda_m^\circ(\text{NaOH}) - \Lambda_m^\circ(\text{NaCl}) &= \Lambda_m^\circ(\text{H}^+) + \Lambda_m^\circ(\text{OH}^-) \\ &= \Lambda_m^\circ(\text{H}_2\text{O}) \end{aligned}$$

(d)

$$\begin{aligned} \Lambda_m^\circ(\text{NH}_4\text{OH}) &= \Lambda_m^\circ(\text{NH}_4^+) + \Lambda_m^\circ(\text{OH}^-) \\ \Lambda_m^\circ(\text{HCl}) &= \Lambda_m^\circ(\text{H}^+) + \Lambda_m^\circ(\text{Cl}^-) \\ \Lambda_m^\circ(\text{NH}_4\text{Cl}) &= \Lambda_m^\circ(\text{NH}_4^+) + \Lambda_m^\circ(\text{Cl}^-) \\ \hline \Lambda_m^\circ(\text{NH}_4\text{OH}) + \Lambda_m^\circ(\text{HCl}) - \Lambda_m^\circ(\text{NH}_4\text{Cl}) &= \Lambda_m^\circ(\text{H}^+) + \Lambda_m^\circ(\text{OH}^-) = \Lambda_m^\circ(\text{H}_2\text{O}) \end{aligned}$$

This type of decomposition is not possible due to weak basic strength of  $\text{NH}_4\text{OH}$ . This line will be placed above.

(b)

$$\begin{aligned} \Lambda_m^\circ(\text{HNO}_3) &= \Lambda_m^\circ(\text{H}^+) + \Lambda_m^\circ(\text{NO}_3^-) \\ \Lambda_m^\circ(\text{NaNO}_3) &= \Lambda_m^\circ(\text{Na}^+) + \Lambda_m^\circ(\text{NO}_3^-) \\ \Lambda_m^\circ(\text{NaOH}) &= \Lambda_m^\circ(\text{Na}^+) + \Lambda_m^\circ(\text{OH}^-) \\ \hline \Lambda_m^\circ(\text{HNO}_3) + \Lambda_m^\circ(\text{NaNO}_3) - \Lambda_m^\circ(\text{NaOH}) &= \Lambda_m^\circ(\text{H}^+) + 2\Lambda_m^\circ(\text{NO}_3^-) - \Lambda_m^\circ(\text{OH}^-) \end{aligned}$$

(b) is incorrect

(c)

$$\begin{aligned} \Lambda_m^\circ(\text{HNO}_3) &= \Lambda_m^\circ(\text{H}^+) + \Lambda_m^\circ(\text{NO}_3^-) \\ \Lambda_m^\circ(\text{NaOH}) &= \Lambda_m^\circ(\text{Na}^+) + \Lambda_m^\circ(\text{OH}^-) \\ \Lambda_m^\circ(\text{NaNO}_3) &= \Lambda_m^\circ(\text{Na}^+) + \Lambda_m^\circ(\text{NO}_3^-) \\ \hline \Lambda_m^\circ(\text{HNO}_3) + \Lambda_m^\circ(\text{NaOH}) - \Lambda_m^\circ(\text{NaNO}_3) &= \Lambda_m^\circ(\text{H}^+) + \Lambda_m^\circ(\text{OH}^-) = \Lambda_m^\circ(\text{H}_2\text{O}) \end{aligned}$$

Hence, Options (a) and (c) are the correct choices.

**Q. 23** What will happen during the electrolysis of aqueous solution of  $\text{CuSO}_4$  by using platinum electrodes?

- (a) Copper will deposit at cathode      (b) Copper will deposit at anode  
(c) Oxygen will be released at anode    (d) Copper will dissolve at anode

**Thinking Process**

*This problem is based on electrolysis of electrolytes.*

**Ans. (a, c)**

For electrolysis of aqueous solution of  $\text{CuSO}_4$ .

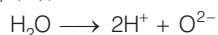
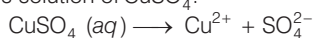

At anode

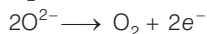

At cathode

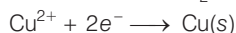

**Q. 24** What will happen during the electrolysis of aqueous solution of  $\text{CuSO}_4$  in the presence of Cu electrodes?

- (a) Copper will deposit at cathode      (b) Copper will dissolve at anode  
(c) Oxygen will be released at anode    (d) Copper will deposit at anode

**Ans. (a, b)**

Electrolysis of  $\text{CuSO}_4$  can be represented by two half cell reactions these occurring at cathode and anode respectively as



Here, Cu will deposit at cathode while copper will dissolved at anode.

Hence, options (a) and (b) are the correct choices.

**Q. 25** Conductivity  $\kappa$ , is equal to.....

(a)  $\frac{1}{R} \frac{l}{A}$

(b)  $\frac{G^*}{R}$

(c)  $\Lambda_m$

(d)  $\frac{l}{A}$

**Ans. (a, b)**

As we know that, conductance is reciprocal of resistance and conductivity is the conductance of  $1 \text{ cm}^3$  of substance. Also, conductivity is reciprocal of resistivity.

$$\kappa = \frac{1}{\rho}$$

$\therefore$

$$R = \rho \frac{l}{A}$$

$$\rho = \frac{R \cdot A}{l} \Rightarrow \kappa = \frac{1}{\left(\frac{R \cdot A}{l}\right)}$$

$$\kappa = \frac{1}{R} \cdot \frac{l}{A} = \frac{1}{R} \times G^* = \frac{G^*}{R}$$

Hence, options (a) and (b) are the correct choices.

**Q. 26** Molar conductivity of ionic solution depends on .....

- (a) temperature  
(b) distance between electrodes  
(c) concentration of electrolytes in solution  
(d) surface area of electrodes

**Ans. (a, c)**

Molar conductivity is the conductivity due to ions furnished by one mole of electrolyte in solution. Molar conductivity of ionic solution depends on

- (i) **Temperature** Molar conductivity of electrolyte solution increases with increase in temperature.  
 (iii) **Concentration of electrolytes in solution** As concentration of electrolyte increases, molar conductivity decreases.

$$\therefore \lambda = \frac{\kappa}{C}$$

**Q. 27** For the given cell,  $\text{Mg} \mid \text{Mg}^{2+} \parallel \text{Cu}^{2+} \mid \text{Cu}$

- (a) Mg is cathode  
 (b) Cu is cathode  
 (c) The cell reaction is  $\text{Mg} + \text{Cu}^{2+} \longrightarrow \text{Mg}^{2+} + \text{Cu}$   
 (d) Cu is the oxidising agent

**Ans. (b, c)**

Left side of cell reaction represents oxidation half cell *i.e.*, oxidation of Mg and right side of cell represents reduction half cell reactions *i.e.*, reduction of copper.

- (ii) Cu is reduced and reduction occurs at cathode.  
 (iii) Mg is oxidised and oxidation occurs at anode.  
 (iv) whole cell reaction can be written as

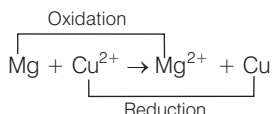

Hence, options (b) and (c) both are correct choices.

## Short Answer Type Questions

**Q. 28** Can absolute electrode potential of an electrode be measured ?

**Ans.** No, only the difference in potential between two electrodes can be measured. This is due to the reason that oxidation or reduction cannot occur alone. So, when we measure electrode potential of any electrode we have to take a reference electrode.

**Q. 29** Can  $E_{\text{cell}}^{\circ}$  or  $\Delta_r G^{\circ}$  for cell reaction ever be equal to zero ?

**Ans.** No, otherwise the reaction become non-feasible.  
 The reaction is feasible only at  $E_{\text{cell}}^{\circ} = \text{positive}$  or  $\Delta_r G^{\circ} = \text{negative}$ .  
 when  $E^{\circ} = \Delta_r G^{\circ} = 0$  the reaction reaches at equilibrium.

**Q. 30** Under what condition is  $E_{\text{cell}} = 0$  or  $\Delta_r G = 0$  ?

**Ans.** At the stage of chemical equilibrium in the cell.

$$\begin{aligned} E_{\text{cell}} &= 0 \\ \Delta_r G^{\circ} &= -n F E_{\text{cell}}^{\circ} \\ &= -n \times F \times 0 = 0 \end{aligned}$$

**Q. 31** What does the negative sign in the expression  $E_{\text{Zn}^{2+}/\text{Zn}}^{\text{s}} = -0.76 \text{ V}$  mean?

**Ans.** Greater the negative reactivity of standard reduction potential of metal greater is its reactivity. It means that Zn is more reactive than hydrogen. When zinc electrode will be connected to standard hydrogen electrode, Zn will get oxidised and  $\text{H}^+$  will get reduced.

Thus, zinc electrode will be the anode of the cell and hydrogen electrode will be the cathode of the cell.

**Q. 32** Aqueous copper sulphate solution and aqueous silver nitrate solution are electrolysed by 1 ampere current for 10 minutes in separate electrolytic cells. Will the mass of copper and silver deposited on the cathode be same or different? Explain your answer.

**Ans.** Different masses of Cu and Ag will be deposited at cathode. According to Faraday's second law of electrolysis amount of different substances liberated by same quantity of electricity passes through electrolyte solution is directly proportional to their chemical equivalent weight.

$$\frac{W_1}{W_2} = \frac{E_1}{E_2}$$

where,  $E_1$  and  $E_2$  have different values depending upon number of electrons required to reduce the metal ion. Thus, masses of Cu and Ag deposited will be different.

**Q. 33** Depict the galvanic cell in which the cell reaction is

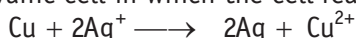

**Ans.** In a galvanic cell, oxidation half reaction is written on left hand side and reduction half reaction is on right hand side. Salt bridge is represented by parallel lines  $\text{Cu} | \text{Cu}^{2+} || \text{Ag}^+ | \text{Ag}$ .

**Q. 34** Value of standard electrode potential for the oxidation of  $\text{Cl}^-$  ions is more positive than that of water, even then in the electrolysis of aqueous sodium chloride, why is  $\text{Cl}^-$  oxidised at anode instead of water?

**Ans.** Under the condition of electrolysis of aqueous sodium chloride, oxidation of water at anode requires over potential. So,  $\text{Cl}^-$  is oxidized at anode instead of water.

Possible oxidation half cell reactions occurring at anode are

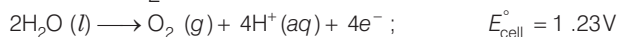
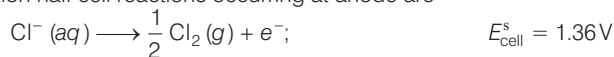

Species having lower  $E_{\text{cell}}^{\circ}$  cell undergo oxidation first than the higher value but oxidation of  $\text{H}_2\text{O}$  to  $\text{O}_2$  is kinetically so slow that it needs some overvoltage.

**Q. 35** What is electrode potential?

**Ans.** The potential difference between the electrode and the electrolyte in an electrochemical cell is called electrode potential.

**Q. 36** Consider the following diagram in which an electrochemical cell is coupled to an electrolytic cell. What will be the polarity of electrodes 'A' and 'B' in the electrolytic cell?

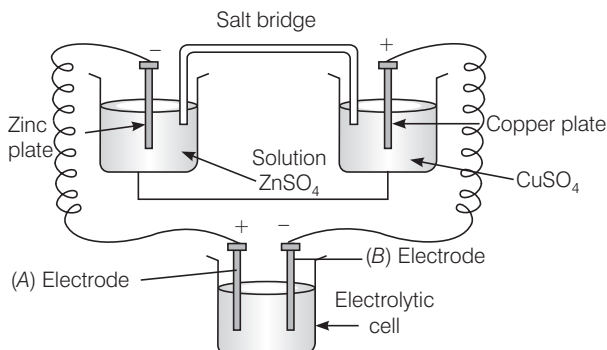

**Ans.** The cell drawn above represents electrochemical cell in which two different electrodes are fitted in their respective electrolytic solution and cell drawn at bottom represents electrolytic cell.

Cell representation can be represented as  $\text{Zn} \mid \text{Zn}^{2+} \parallel \text{Cu}^{2+} \mid \text{Cu}$ .

Zn is losing electrons which are going towards electrode (A) and copper is accepting electron from electrode B. Hence,

Charge on electrode A = +

Charge on electrode B = -

**Q. 37** Why is alternating current used for measuring resistance of an electrolytic solution?

**Ans.** Alternating current is used in electrolysis so that concentration of ions in the solution remains constant and exact value of resistance is measured.

**Q. 38** A galvanic cell has electrical potential of 1.1V. If an opposing potential of 1.1V is applied to this cell, what will happen to the cell reaction and current flowing through the cell ?

**Ans.** When an opposing potential of 1.1V is applied to a galvanic cell having electrical potential of 1.1V then cell reaction stops completely and no current will flow through the cell.

**Q. 39** How will the pH of brine (aq NaCl solution) be affected when it is electrolysed?

**Ans.** The pH of the solution will rise as NaOH is formed in the electrolytic cell.

Chemical reaction occurring at cell when aqueous brine solution is electrolysed are as follows

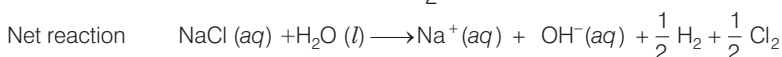
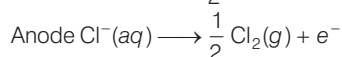
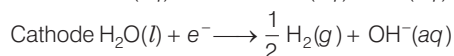
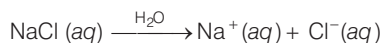



**Q. 40** Unlike dry cell, the mercury cell has a constant cell potential throughout its useful life. Why ?

**Ans.** Life time of any cell depends upon ions present in cell. Ions are not involved in the overall cell reaction of mercury cell. Hence, mercury cell has a constant cell potential throughout its useful life.

**Q. 41** Solutions of two electrolytes A and B are diluted. The  $\Lambda_m$  of 'B' increases 1.5 times while that of A increases 25 times. Which of the two is a strong electrolyte ? Justify your answer.

**Ans.** Strong electrolytes dissociate almost completely even on high concentration. Therefore, concentration of such solutions remain almost same on dilution. Electrolyte 'B' is stronger than 'A' because in 'B' the number of ions remains the same on dilution, but only interionic attraction decreases.

Therefore,  $\Lambda_m$  increases only 1.5 times. While in case of weak electrolyte on dilution, number of constituent ions increases.

**Q. 42** When acidulated water (dil.  $H_2SO_4$  solution) is electrolysed, with pH of the solution be affected ? Justify your answer.

**Ans.** Since pH of solution depends upon concentration of  $H^+$  presence in solutions. pH of the solution will not be affected as  $[H^+]$  remains constant.

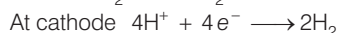
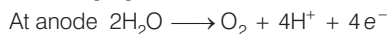

**Q. 43** In an aqueous solution how does specific conductivity of electrolytes change with addition of water?

**Ans.** Conductivity of solution due to total ions present in per unit volume of solution is known as specific conductivity. Specific conductivity decreases due to decrease in the number of ions per unit volume. We add water to aqueous solution, number of ions present in per unit volume decreases.

**Q. 44** Which reference electrode is used to measure the electrode potential of other electrodes?

**Ans.** Standard hydrogen electrode (SHE) is the reference electrode whose electrode potential is taken to be zero. The electrode potential of other electrodes are measured with respect to it .

**Q. 45** Consider a cell given below



Write the reactions that occur at anode and cathode.

**Ans.** Cell reaction represented in the question is composed of two half cell reactions. These reactions are as follows

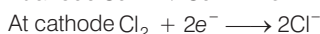
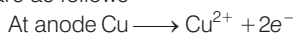

Copper is getting oxidised at anode.  $Cl_2$  is getting reduced at cathode.

**Q. 46** Write the Nernst equation for the cell reaction in the Daniel cell. How will the  $E_{\text{cell}}$  be affected when concentration of  $\text{Zn}^{2+}$  ions is increased?

**Ans.**  $\text{Zn} + \text{Cu}^{2+} \longrightarrow \text{Zn}^{2+} + \text{Cu}$

$$E_{\text{cell}} = E_{\text{cell}}^{\circ} - \frac{0.0591}{2} \log \left[ \frac{\text{Zn}^{2+}}{\text{Cu}^{2+}} \right]$$

$$E_{\text{cell}}^{\circ} = E_{\text{cell}} + \frac{0.0591}{2} \log \left[ \frac{\text{Cu}^{2+}}{\text{Zn}^{2+}} \right]$$

According to this equation

$E_{\text{cell}}^{\circ}$  is directly dependent on concentration of  $\text{Cu}^{2+}$  and inversely dependent upon concentration of  $\text{Zn}^{2+}$  ions.

$E_{\text{cell}}$  decreases when concentration of  $\text{Zn}^{2+}$  ions is increased.

**Q. 47** What advantage do the fuel cells have over primary and secondary batteries ?

**Ans.** Primary batteries contain a limited amount of reactants and are discharged when the reactants have been consumed. Secondary batteries can be recharged but it take a long time. Fuel cell run continuously as long as the reactants are supplied to it and products are removed continuously.

**Q. 48** Write the cell reaction of a lead storage battery when it is discharged. How does the density of the electrolyte change when the battery is discharged?

**Ans.** When a lead storage battery is discharged then the following cell reaction takes place

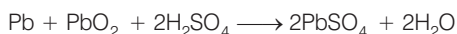

Density of electrolyte depends upon number.of constituent ions present in per unit volume of electrolyte solution.In this case density of electrolyte decreases as water is formed and sulphuric acid is consumed as the product during discharge of the battery.

**Q. 49** Why on dilution the  $\Lambda_m$  of  $\text{CH}_3\text{COOH}$  increases drastically, while that of  $\text{CH}_3\text{COONa}$  increases gradually?

**Ans.** In the case of  $\text{CH}_3\text{COOH}$ , which is a weak electrolyte, the number of ions increase on dilution due to an increase in degree of dissociation.



In case of strong electrolyte, the number of ions remains the same but the interionic attraction decreases.

## Matching The Columns

**Q. 50** Match the terms given in Column I with the units given in Column II.

Column I	Column II
A. $\wedge_m$	1. $S\text{ cm}^{-1}$
B. $E_{\text{cell}}$	2. $\text{m}^{-1}$
C. $\kappa$	3. $S\text{ cm}^2\text{ mol}^{-1}$
D. $G^*$	4. $V$

**Ans.** A.  $\rightarrow$  (3)    B.  $\rightarrow$  (4)    C.  $\rightarrow$  (1)    D.  $\rightarrow$  (2)

Column I	Column II (Unit of parameter)
A. $\wedge_m$	$S\text{ cm}^2\text{ mol}^{-1}$
B. $E_{\text{cell}}$	$V$
C. $\kappa$ (conductivity)	$S\text{ cm}^{-1}$
D. $G^* = \frac{l}{a}$	$\text{m}^{-1}$

**Q. 51** Match the terms given in Column I with the items given in Column II.

Column I	Column II
A. $\wedge_m$	1. Intensive property
B. $E_{\text{cell}}^s$	2. Depends on number of ions/volume
C. $\kappa$	3. Extensive property
D. $\Delta_r G_{\text{cell}}$	4. Increases with dilution

**Ans.** A.  $\rightarrow$  (4)    B.  $\rightarrow$  (1)    C.  $\rightarrow$  (2)    D.  $\rightarrow$  (3)

- A.  $\wedge_m$  (molar conductivity) is the conductivity due to number of ions furnished by one mole of electrolyte. As dilution increases number of ions present in the solution increases hence molar conductivity increases.
- B.  $E_{\text{cell}}^s$  of any atom/ion does not depend upon number of atom/ion, hence  $E_{\text{cell}}^s$  of any atom/ion is an intensive properties.
- C.  $\kappa$  represents specific conductivity which depends upon number of ions present in per unit volume.
- D.  $\Delta_r G_{\text{cell}}$  is an extensive property as it depends upon number of particles(species).

**Q. 52** Match the items of Column I and Column II.

Column I	Column II
A. Lead storage battery	1. Maximum efficiency
B. Mercury cell	2. Prevented by galvanisation
C. Fuel cell	3. Gives steady potential
D. Rusting	4. Pb is anode, PbO <sub>2</sub> is cathode

**Ans.** A. → (4) B. → (3) C. → (1) D. → (2)

A. Chemical reaction occurring on lead storage battery can be represented as

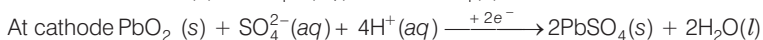
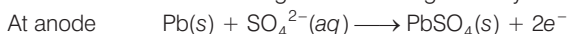

Thus, Pb is anode and PbO<sub>2</sub> is cathode.

B. Mercury cell does not include ions during their function hence produce steady current.

C. Fuel cell has maximum efficiency as they produce energy due to combustion reaction of fuel.

D. Rusting is prevented by corrosion.

**Q. 53** Match the items of Column I and Column II.

Column I	Column II
A. $\kappa$	1. $I \times t$
B. $\wedge_m$	2. $\wedge_m / \wedge_m^0$
C. $\alpha$	3. $\frac{\kappa}{C}$
D. $Q$	4. $\frac{G^*}{R}$

**Ans.** A. → (4) B. → (3) C. → (2) D. → (1)

A. Conductivity ( $\kappa$ ) =  $\frac{G^*}{R}$

B. Molar conductivity ( $\wedge_m$ ) =  $\frac{\kappa}{C}$

C. Degree of dissociation ( $\alpha$ ) =  $\frac{\wedge_m}{\wedge_m^0}$

D. Charge  $Q = I \times t$

where,  $Q$  is the quantity of charge in coulomb when  $I$  ampere of current is passed through an electrolyte for  $t$  second.

**Q. 54** Match the items of Column I and Column II.

Column I	Column II
A. Lechlanche cell	1. Cell reaction $2\text{H}_2 + \text{O}_2 \longrightarrow 2\text{H}_2\text{O}$
B. Ni-Cd cell	2. Does not involve any ion in solution and is used in hearing aids.
C. Fuel cell	3. Rechargeable
D. Mercury cell	4. Reaction at anode, $\text{Zn} \longrightarrow \text{Zn}^{2+} + 2e^-$
	5. Converts energy of combustion into electrical energy

**Ans. A.** → (4) **B.** → (3) **C.** → (1, 5) **D.** → (2)

A. Lechlanche cell The electrode reaction occurs at Lechlanche cell are

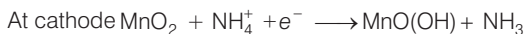
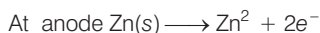

B. Ni-Cd cell is rechargeable. So, it has more life time.

C. Fuel cell produces energy due to combustion. So, fuel cell converts energy of combustion into electrical energy e.g.,  $2\text{H}_2 + \text{O}_2 \longrightarrow 2\text{H}_2\text{O}$

D. Mercury cell does not involve any ion in solution and is used in hearing aids.

**Q. 55** Match the items of Column I and Column II on the basis of data given below

$$E_{\text{F}_2/\text{F}^-}^{\text{S}} = 2.87\text{V}, E_{\text{Li}^+/\text{Li}}^{\text{S}} = -3.5\text{V},$$

$$E_{\text{Au}^{3+}/\text{Au}}^{\text{S}} = 1.4\text{V}, E_{\text{Br}_2/\text{Br}^-}^{\text{S}} = 1.09\text{V}$$

Column I	Column II
A. $\text{F}_2$	1. Metal is the strongest reducing agent
B. Li	2. Metal ion which is the weakest oxidising agent
C. $\text{Au}^{3+}$	3. Non-metal which is the best oxidising agent
D. $\text{Br}^-$	4. Unreactive metal
E. Au	5. Anion that can be oxidised by $\text{Au}^{3+}$
F. $\text{Li}^+$	6. Anion which is the weakest reducing agent
G. $\text{F}^-$	7. Metal ion which is an oxidising agent

**Ans. A.** → (3) **B.** → (1) **C.** → (7) **D.** → (5) **E.** → (4) **F.** → (2) **G.** → (6)

A.  $\text{F}_2$  is a non-metal and best oxidising agent because SRP of  $\text{F}_2$  is + 2.87 V.

B. Li is a metal and strongest reducing agent because SRP of Li is – 3.05 V.

C.  $\text{Au}^{3+}$  is a metal ion which is an oxidising agent as SRP of  $\text{Au}^{3+}$  is +1.40 V.

D.  $\text{Br}^-$  is an anion that can be oxidised by  $\text{Au}^{3+}$  as  $\text{Au}^{3+}$  ( $E^\circ = 1.40$ ) is greater than

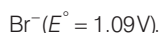

E. Au is an unreactive metal.

F.  $\text{Li}^+$  is a metal ion having least value of SRP (– 3.05 V), hence it is the weakest oxidising agent.

G.  $\text{F}^-$  is an anion which is the weakest reducing agent as  $\text{F}^- / \text{F}_2$  has low oxidation potential (–2.87 V).

## Assertion and Reason

*In the following questions a statement of assertion (A) followed by a statement of reason (R) is given. Choose the correct answer out of the following choices.*

- (a) Both assertion and reason are true and the reason is the correct explanation of assertion.
- (b) Both assertion and reason are true and reason is not the correct explanation of assertion.
- (c) Assertion is true but the reason is false.
- (d) Both assertion and reason are false.
- (e) Assertion is false but reason is true.

**Q. 56** Assertion (A) Cu is less reactive than hydrogen.

Reason (R)  $E_{\text{Cu}^{2+}/\text{Cu}}^{\circ}$  is negative.

**Ans. (c)** Assertion is true but the reason is false. Electrode potential of  $\text{Cu}^{2+}/\text{Cu}$  is + 0.34V and Electrode potential of  $2\text{H}^{+}/\text{H}_2$  is 0.00 V.  
Hence, correct reason is due to positive value of  $\text{Cu}^{2+}/\text{Cu}$  it loses electron to  $\text{H}^{+}$  and get reduced, while  $\text{H}_2$  gas evolves out.

**Q. 57** Assertion (A)  $E_{\text{cell}}$  should have a positive value for the cell to function.

Reason (R)  $E_{\text{cathode}} < E_{\text{anode}}$

**Ans. (c)** Assertion is true but the reason is false. Feasibility of chemical reaction depends on Gibbs free energy which is related to  $E_{\text{cell}}^{\circ}$  as  
$$\Delta G^{\circ} = -nFE_{\text{cell}}^{\circ}$$
When value of  $E_{\text{cell}}^{\circ}$  is positive then  $\Delta G^{\circ}$  becomes negative. Hence, reaction becomes feasible.  
Correct reason is  $E_{\text{cathode}} > E_{\text{anode}}$ .

**Q. 58** Assertion (A) Conductivity of all electrolytes decreases on dilution.

Reason (R) On dilution number of ions per unit volume decreases.

**Ans. (a)** Both assertion and reason are correct and reason is the correct explanation of assertion.  
Since, conductivity depends upon number of ions per unit volume. Therefore, the conductivity of all electrolytes decreases on dilution due to decrease in number of ions per unit volume.

**Q. 59** Assertion (A)  $\Lambda_m$  for weak electrolytes shows a sharp increase when the electrolytic solution is diluted.

Reason (R) For weak electrolytes degree of dissociation increases with dilution of solution.

**Ans. (a)** Assertion and reason are true and the reason is the correct explanation of the assertion.  
Molar conductivity of weak electrolytic solution increases on dilution, because as we add excess water to increase the dilution degree of dissociation increases which lead to increase in number of ions in the solution. Thus,  $\Lambda_m$  show a very sharp increase.

- Q. 60** Assertion (A) Mercury cell does not give steady potential.  
Reason (R) In the cell reaction, ions are not involved in solution.

**Ans. (e)** Assertion is false but reason is true. Correct assertion is mercury cell gives steady potential.  
Reason is correct as ions are not involved in cell reaction.

- Q. 61** Assertion (A) Electrolysis of NaCl solution gives chlorine at anode instead of  $O_2$ .  
Reason (R) Formation of oxygen at anode requires over voltage.

**Ans. (a)** Both assertion and reason are correct and reason is the correct explanation of assertion.

**Explanation** Electrolysis of NaCl is represented by following chemical reactions

At cathode

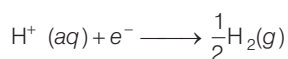

At anode

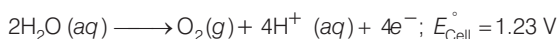
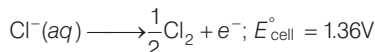

$E_{cell}^\circ$  for this reaction has lower value but formation of oxygen at anode requires over potential.

- Q. 62** Assertion (A) For measuring resistance of an ionic solution an AC source is used.  
Reason (R) Concentration of ionic solution will change if DC source is used.

**Ans. (a)** Both assertion and reason are correct and reason is the correct explanation of assertion.

Concentration of ionic solution changes on using DC current as a source of energy while on passing AC current concentration does not change. Hence, AC source is used for measuring resistance.

- Q. 63** Assertion (A) Current stops flowing when  $E_{cell} = 0$ .  
Reason (R) Equilibrium of the cell reaction is attained.

**Ans. (a)** Both assertion and reason are correct and reason is the correct explanation of assertion.

Current stop flowing when  $E_{cell} = 0$

As at  $E_{cell} = 0$  reaction reaches the equilibrium.

**Q. 64** Assertion (A)  $E_{\text{Ag}^+/\text{Ag}}$  increase with increase in concentration of  $\text{Ag}^+$  ions.

Reason (R)  $E_{\text{Ag}^+/\text{Ag}}$  has a positive value.

**Ans. (b)** Both assertion and reason are correct but reason is not the correct explanation of assertion.

$$E = E^\circ - \frac{0.0591}{1} \log \frac{1}{[\text{Ag}^+]}$$

$$E = E^\circ + 0.059 \log [\text{Ag}^+]$$

Thus,  $E_{\text{Ag}^+/\text{Ag}}$  increases with increase in concentration of  $\text{Ag}^+$ .

**Q. 65** Assertion (A) Copper sulphate can be stored in zinc vessel.

Reason (R) Zinc is less reactive than copper.

**Ans. (d)** Both assertion and reason are false.

Copper sulphate can't be stored in zinc vessel as zinc is more reactive than copper due to negative value of standard reduction potential of Zn.

## Long Answer Type Questions

**Q. 66** Consider the figure and answer the following questions.

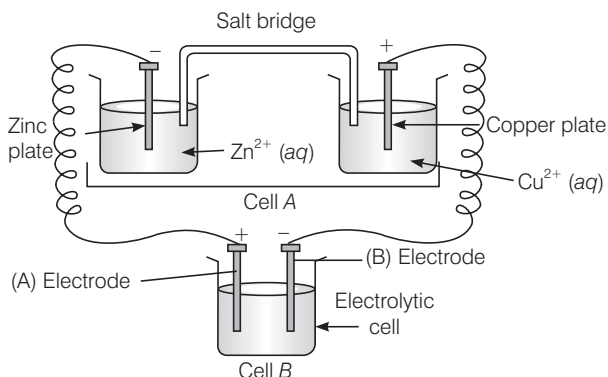

- (i) Cell 'A' has  $E_{\text{cell}} = 2\text{V}$  and Cell 'B' has  $E_{\text{cell}} = 1.1\text{V}$  which of the two cells 'A' or 'B' will act as an electrolytic cell. Which electrode reactions will occur in this cell?
- (ii) If cell 'A' has  $E_{\text{cell}} = 0.5\text{V}$  and cell 'B' has  $E_{\text{cell}} = 1.1\text{V}$  then what will be the reactions at anode and cathode?

### Thinking Process

*This problem includes concept of electrochemical cell, electrolytic cell and charge on electrode. To solve this problem identify the charge on each electrode first.*



**Ans. (i)** Cell 'B' will act as electrolytic cell due to its lesser value of emf.

The electrode reactions will be



**(ii)** If cell 'B' has higher emf, it acts as galvanic cell.

Now it will push electrons into cell 'A'

In this case, the reactions will be

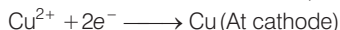

**Q. 67** Consider figure from the above question and answer the questions (i) to (vi) given below.

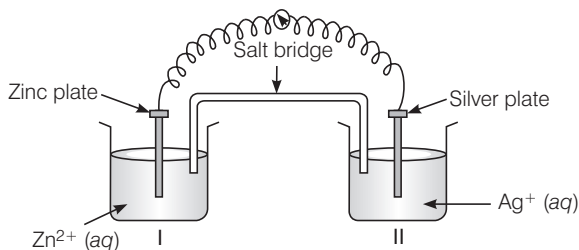

- (i) Redraw the diagram to show the direction of electron flow.
- (ii) Is silver plate the anode or cathode?
- (iii) What will happen if salt bridge is removed?
- (iv) When will the cell stop functioning?
- (v) How will concentration of  $\text{Zn}^{2+}$  ions and  $\text{Ag}^+$  ions be affected when the cell functions?
- (vi) How will the concentration of  $\text{Zn}^{2+}$  ions and  $\text{Ag}^+$  ions be affected after the cell becomes 'dead'?

**Ans. (i)** Electrons move from Zn to Ag as  $E^\circ$  is more negative for Zn, so Zn undergoes oxidation and  $\text{Ag}^+$  undergoes reduction.

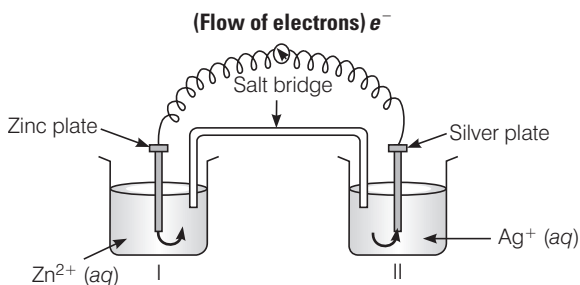

- (ii) Ag is the cathode as it is the site of reduction where  $\text{Ag}^+$  takes electrons from medium and deposit at cathode.
- (iii) Cell will stop functioning because cell potential drops to zero. At  $E = 0$  reaction reaches equilibrium.

- (iv) When  $E_{\text{cell}} = 0$  because at this condition reaction reaches to equilibrium.
- (v) Concentration of  $\text{Zn}^{2+}$  ions will increase and concentration of  $\text{Ag}^+$  ions will decrease because Zn is converted into  $\text{Zn}^{2+}$  and  $\text{Ag}^+$  is converted into Ag.
- (vi) When  $E_{\text{cell}} = 0$  equilibrium is reached and concentration of  $\text{Zn}^{2+}$  ions and  $\text{Ag}^+$  will not change.

**Q. 68** What is the relationship between Gibbs free energy of the cell reaction in a galvanic cell and the emf of the cell? When will the maximum work be obtained from a galvanic cell?

**Ans.** If concentration of all reacting species is unity, then  $E_{\text{cell}} = E_{\text{cell}}^{\circ}$  and  $\Delta G^{\circ} = -nFE_{\text{cell}}^{\circ}$  where,  $\Delta_r G^{\circ}$  is standard Gibbs energy of the reaction

$$E_{\text{cell}}^{\circ} = \text{emf of the cell}$$

$$nF = \text{charge passed}$$

If we want to obtain maximum work from a galvanic cell then charge has to be passed reversibly.

The reversibly work done by a galvanic cell is equal to decrease in its Gibbs energy.

$$\Delta_r G = -nFE_{\text{cell}}$$

As  $E_{\text{cell}}$  is an intensive parameter but  $\Delta_r G$  is an extensive thermodynamic property and the value depends on  $n$ .

For reaction,  $\text{Zn (s)} + \text{Cu}^{2+}(\text{aq}) \longrightarrow \text{Zn}^{2+}(\text{aq}) + \text{Cu (s)}$  in a galvanic cell.

$$\Delta_r G = -2FE_{\text{cell}} \quad [\text{Here, } n = 2]$$

# Chemical Kinetics

## Multiple Choice Questions (MCQs)

**Q. 1** The role of a catalyst is to change .....

- (a) Gibbs energy of reaction                      (b) enthalpy of reaction  
(c) activation energy of reaction                (d) equilibrium constant

**Ans. (c)** The role of a catalyst is to change the activation energy of reaction. This is done by either increasing or decreasing activation energy of molecule as catalyst are mainly of two types; +ve catalyst and -ve catalyst.

**Note** Catalyst are of two types one is positive catalyst which increases rate of reaction by decreasing activation energy and another is negative catalyst which decreases rate of reaction by increasing energy of activation.

**Q. 2** In the presence of a catalyst, the heat evolved or absorbed during the reaction .....

- (a) increases    (b) decreases  
(c) remains unchanged                                (d) may increase or decrease

**Ans. (c)** In the presence of catalyst, the heat absorbed, or evolved during the reaction remains unchanged as there is no change in stability of reactant and product.

**Q. 3** Activation energy of a chemical reaction can be determined by .....

- (a) determining the rate constant at standard temperature  
(b) determining the rate constant at two temperatures  
(c) determining probability of collision  
(d) using catalyst

**Ans. (b)** Activation energy of a chemical reaction is related to rate constant of a reaction at two different temperatures *i.e.*,  $k_1$  and  $k_2$  respectively

$$\ln \left( \frac{k_1}{k_2} \right) = \frac{E_a}{R} \left[ \frac{1}{T_1} - \frac{1}{T_2} \right]$$

where,

$E_a$  = activation energy

$T_2$  = higher temperature

$T_1$  = lower temperature

$k_1$  = rate constant at temperature  $T_1$

$k_2$  = rate constant at temperature  $T_2$

This equation is known as Arrhenius equation.

**Q. 4** Consider figure and mark the correct option.

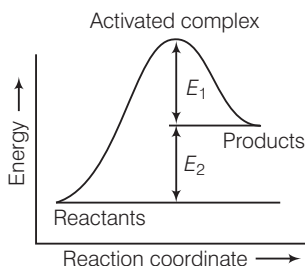

- (a) Activation energy of forward reaction is  $E_1 + E_2$  and product is less stable than reactant
- (b) Activation energy of forward reaction is  $E_1 + E_2$  and product is more stable than reactant
- (c) Activation energy of both forward and backward reaction is  $E_1 + E_2$  and reactant is more stable than product
- (d) Activation energy of backward reaction is  $E_1$  and product is more stable than reactant

**Ans. (a)** Activation energy is the minimum energy required to convert reactant molecules to product molecules. Here, the energy gap between reactants and activated complex is sum of  $E_1$  and  $E_2$ .

$$\therefore \text{Activation energy} = E_1 + E_2$$

Product is less stable than reactant as energy of product is greater than the reactant.

**Q. 5** Consider a first order gas phase decomposition reaction given below

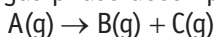

The initial pressure of the system before decomposition of A was  $p_i$ . After lapse of time 't' total pressure of the system increased by x units and became ' $p_t$ '. The rate constant k for the reaction is given as .....

- (a)  $k = \frac{2.303}{t} \log \frac{p_i}{p_i - x}$
- (b)  $k = \frac{2.303}{t} \log \frac{p_i}{2p_i - p_t}$
- (c)  $k = \frac{2.303}{t} \log \frac{p_i}{2p_i + p_t}$
- (d)  $k = \frac{2.303}{t} \log \frac{p_i}{p_i + x}$

**Thinking Process**

This problem is based on first order rate of reaction. To solve this question determine the value of total pressure then calculate value of x followed by rate constant. where, x = pressure of gas transform to product

**Ans. (b)**

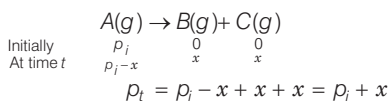

$$p_t = p_i - x + x + x = p_i + x$$

$$x = p_t - p_i$$

$$k = \frac{2.303}{t} \log \frac{p_i}{p_i - x}$$

$$= \frac{2.303}{t} \log \frac{p_i}{p_i - (p_t - p_i)}$$

$$= \frac{2.303}{t} \log \frac{p_i}{2p_i - p_t}$$

**Q. 6** According to Arrhenius equation rate constant  $k$  is equal to  $A e^{-E_a/RT}$ . Which of the following options represents the graph of  $\ln k$  vs  $\frac{1}{T}$ ?

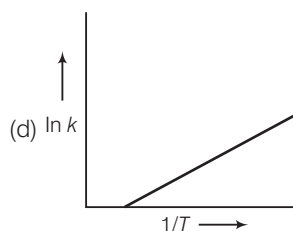
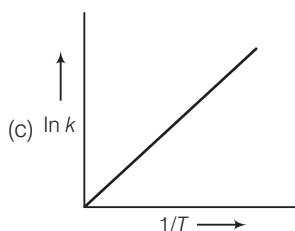
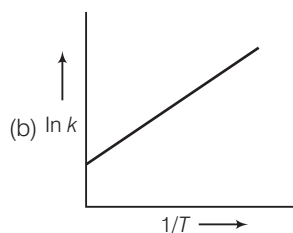
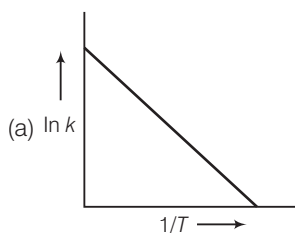

**Thinking Process**

This problem includes graphical representation of Arrhenius equation. To solve this problem transform the Arrhenius equation into equation of straight line taking  $\ln k$  on  $x$ -axis and  $\frac{1}{T}$  on  $y$ -axis

**Ans. (a)** According to Arrhenius equation,  $k = A e^{-E_a/RT}$

Taking log on both side  $\ln k = \ln(A e^{-E_a/RT})$

$$\ln k = \ln A - \frac{E_a}{RT}$$

$$\ln k = -\frac{E_a}{R} \times \frac{1}{T} + \ln A$$

$$y = m x + c$$

This equation can be related to equation of straight line as shown above.

From the graph, it is very clear that slope of the plot =  $-\frac{E_a}{R}$  and intercept =  $\ln A$ .

**Q. 7** Consider the Arrhenius equation given below and mark the correct option.

$$k = A e^{-\frac{E_a}{RT}}$$

- (a) Rate constant increases exponentially with increasing activation energy and decreasing temperature
- (b) Rate constant decreases exponentially with increasing activation energy and decreasing temperature
- (c) Rate constant increases exponentially with decreasing activation energy and decreasing temperature
- (d) Rate constant increases exponentially with decreasing activation energy and increasing temperature

**Ans. (d)** According to Arrhenius equation  $k = A e^{-E_a/RT}$

Here,  $k \propto e^{-E_a}$

$$k \propto e^{-\frac{1}{T}}$$

$$\propto e^T$$

which indicates that as activation energy decreases rate constant increases and as temperature increases rate of reaction increases.

**Q. 8** A graph of volume of hydrogen released vs time for the reaction between zinc and dil. HCl is given in figure. On the basis of this mark the correct option.

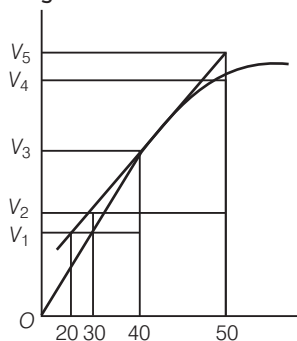

- (a) Average rate upto 40 s is  $\frac{V_3 - V_2}{40}$       (b) Average rate upto 40 s is  $\frac{V_3 - V_2}{40 - 30}$   
 (c) Average rate upto 40 s is  $\frac{V_3}{40}$       (d) Average rate upto 40 s is  $\frac{V_3 - V_1}{40 - 20}$

**Ans. (c)**  $Zn + \text{Dil. HCl} \longrightarrow ZnCl_2 + H_2 \uparrow$

$$\text{Average rate of reaction} = \frac{\text{Change in concentration of } H_2}{\text{Change in time}} = \frac{V_3 - 0}{40 - 0} = \frac{V_3}{40}$$

**Q. 9** Which of the following statements is not correct about order of a reaction?

- (a) The order of a reaction can be a fractional number  
 (b) Order of a reaction is experimentally determined quantity  
 (c) The order of a reaction is always equal to the sum of the stoichiometric coefficients of reactants in the balanced chemical equation for a reaction  
 (d) The order of a reaction is the sum of the powers of molar concentration of the reactants in the rate law expression

**Ans. (c)** Out of the given four statements, option (c) is not correct.

**Order of Reaction**

Order of reaction is equal to the sum of powers of concentration of the reactants in rate law expression.

For any chemical reaction



$$\text{Rate} = k [A]^x [B]^y$$

$$\text{Order} = x + y$$

Order of reaction can be a fraction also. Order of reaction is not always equal to sum of the stoichiometric coefficients of reactants in the balanced chemical equation. For a reaction it may or may not be equal to sum of stoichiometric coefficient of reactants.

**Q. 10** Consider the graph given in figure. Which of the following options does not show instantaneous rate of reaction at 40s?

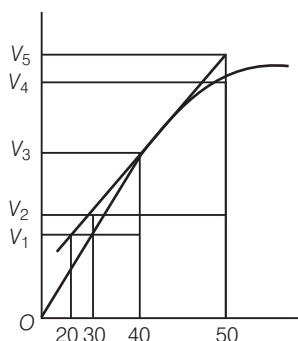

- (a)  $\frac{V_5 - V_2}{50 - 30}$       (b)  $\frac{V_4 - V_2}{50 - 30}$       (c)  $\frac{V_3 - V_2}{40 - 30}$       (d)  $\frac{V_3 - V_1}{40 - 20}$

**Ans. (b)** Reaction occurring at smallest time interval is known as instantaneous rate of reaction e.g., instantaneous rate of reaction at 40 s is rate of reaction during a small interval of time close to 40 s. Volume change during a small time interval close to 40 s i.e., 40 – 30 s, 50 – 40 s, 50 – 30 s, 40 – 20 s.

$$\text{Instantaneous rate of reaction} = \frac{\text{Change in volume}}{\text{Time interval close to 40 s}}$$

- (a)  $r_{\text{inst}} (20 \text{ s}) = \frac{V_5 - V_2}{50 - 30}$  correct  
 (b)  $r_{\text{inst}} (20 \text{ s}) = \frac{V_4 - V_3}{50 - 30}$  incorrect, correct is  $\frac{V_5 - V_3}{50 - 30}$   
 (c)  $r_{\text{inst}} (10 \text{ s}) = \frac{V_3 - V_2}{40 - 30}$  correct  
 (d)  $r_{\text{inst}} (20 \text{ s}) = \frac{V_3 - V_1}{40 - 20}$  correct

**Q. 11** Which of the following statements is correct?

- (a) The rate of a reaction decreases with passage of time as the concentration of reactants decreases  
 (b) The rate of a reaction is same at any time during the reaction  
 (c) The rate of a reaction is independent of temperature change  
 (d) The rate of a reaction decreases with increase in concentration of reactant (s)

**Ans. (a)** Rate of reaction is defined as rate of decrease of concentration of any one of reactant with passage of time

$$\text{Rate of reaction} = \frac{\text{Rate of disappearance of reactant}}{\text{Time taken}}$$

$$r = \frac{-dx}{dt}$$

Thus, as the concentration of reactant decreases with passage of time, rate of reaction decreases.

**Q. 12** Which of the following expressions is correct for the rate of reaction given below?

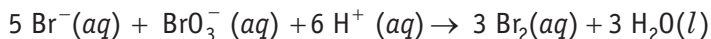

(a)  $\frac{\Delta[\text{Br}^-]}{\Delta t} = 5 \frac{\Delta[\text{H}^+]}{\Delta t}$

(b)  $\frac{\Delta[\text{Br}^-]}{\Delta t} = \frac{6}{5} \frac{\Delta[\text{H}^+]}{\Delta t}$

(c)  $\frac{\Delta[\text{Br}^-]}{\Delta t} = \frac{5}{6} \frac{\Delta[\text{H}^+]}{\Delta t}$

(d)  $\frac{\Delta[\text{Br}^-]}{\Delta t} = 6 \frac{\Delta[\text{H}^+]}{\Delta t}$

**Ans. (c)** Given, chemical reaction is

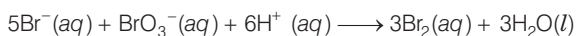

Rate law expression for the above equation can be written as

$$-\frac{1}{5} \frac{\Delta[\text{Br}^-]}{\Delta t} = -\frac{\Delta[\text{BrO}_3^-]}{\Delta t} = \frac{-1}{6} \frac{\Delta[\text{H}^+]}{\Delta t} = \frac{+1}{3} \frac{\Delta[\text{Br}_2]}{\Delta t}$$

$$\Rightarrow \frac{\Delta[\text{Br}^-]}{\Delta t} = -\frac{\Delta[\text{BrO}_3^-]}{\Delta t} = \frac{-5}{6} \frac{\Delta[\text{H}^+]}{\Delta t}$$

$$\Rightarrow \frac{\Delta[\text{Br}^-]}{\Delta t} = \frac{5}{6} \frac{\Delta[\text{H}^+]}{\Delta t}$$

**Q. 13** Which of the following graphs represents exothermic reaction?

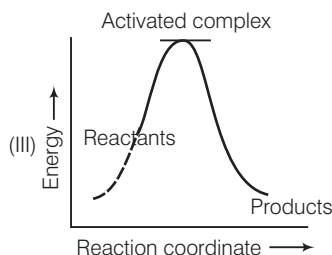
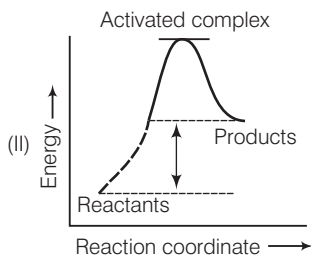
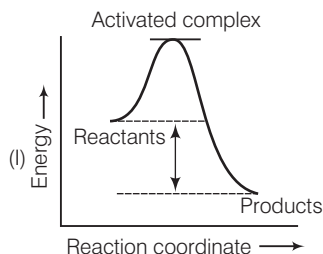

(a) Only (I)

(b) Only(II)

(c) Only(III)

(d) (I) and (II)

**Ans. (a)** The chemical reaction in which energy is evolved during the reaction is known as exothermic reaction *i.e.*, activation energy of product is greater than activation energy of reactants.

Here, only (I) denotes correct picture of exothermic reaction.

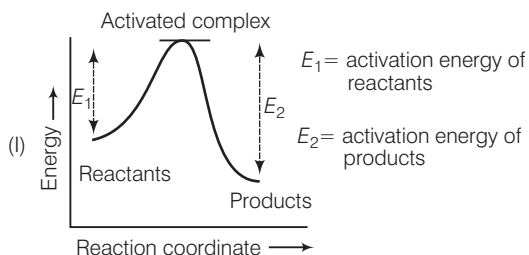



**Q. 14** Rate law for the reaction  $A + 2B \longrightarrow C$  is found to be

$$\text{Rate} = k[A][B]$$

Concentration of reactant 'B' is doubled, keeping the concentration of 'A' constant, the value of rate constant will be..... .

- (a) the same (b) doubled  
(c) quadrupled (d) halved

**Ans. (b)** Rate law can be written as

$$\text{Rate} = k[A][B]$$

Rate of reaction w.r.t B is of first order.

$$R_1 = k [A] [B]$$

when concentration of reactant 'B' is doubled then rate ( $R_2$ )

$$R_2 = k [A] [2B]$$

$$R_2 = 2k [A] [B]$$

$$R_2 = 2 R_1$$

Therefore; as concentration of B is doubled keeping the concentration of A constant rate of reaction doubles.

**Q. 15** Which of the following statements is incorrect about the collision theory of chemical reaction?

- (a) It considers reacting molecules or atoms to be hard spheres and ignores their structural features  
(b) Number of effective collisions determines the rate of reaction  
(c) Collision of atoms or molecules possessing sufficient threshold energy results into the product formation  
(d) Molecules should collide with sufficient threshold energy and proper orientation for the collision to be effective

**Ans. (c)** According to the postulates of collision theory there are following necessary conditions for any reaction to occur

- (i) Molecule should collide with sufficient threshold energy.  
(ii) Their orientation must be proper.  
(iii) The collision must be effective.

**Q. 16** A first order reaction is 50% completed in  $1.26 \times 10^{14}$  s. How much time would it take for 100% completion?

- (a)  $1.26 \times 10^{15}$  s (b)  $2.52 \times 10^{14}$  s  
(c)  $2.52 \times 10^{28}$  s (d) Infinite

**Ans. (d)** The time taken for half the reaction to complete. i.e., the time in which the concentration of a reactant is reduced to half of its original value is called half-life period of the reaction.

But it is impossible to perform 100% of the reaction. Whole of the substance never reacts because in every half-life, 50% of the substance reacts. Hence, time taken for 100% completion of a reaction is infinite.

**Q. 17** Compounds 'A' and 'B' react according to the following chemical equation.

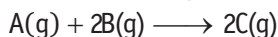

Concentration of either 'A' or 'B' were changed keeping the concentrations of one of the reactants constant and rates were measured as a function of initial concentration. Following results were obtained. Choose the correct option for the rate equations for this reaction.

Experiment	Initial concentration of [A]/mol L <sup>-1</sup>	Initial concentration of [B]/mol L <sup>-1</sup>	Initial concentration of [C]/mol L <sup>-1</sup> s <sup>-1</sup>
1.	0.30	0.30	0.10
2.	0.30	0.60	0.40
3.	0.60	0.30	0.20

(a) Rate =  $k[A]^2[B]$

(b) Rate =  $k[A][B]^2$

(c) Rate =  $k[A][B]$

(d) Rate =  $k[A]^2[B]^0$

**Ans. (b)** Rate of reaction is change in concentration of reactant with respect to time.

$$r = k[A]^x[B]^y$$

$$\text{Rate of exp.1} = \frac{[0.30]^x [0.30]^y}{[0.30]^x [0.60]^y}$$

$$\text{Rate of exp.2} = \frac{[0.30]^x [0.30]^y}{[0.30]^x [0.60]^y}$$

$$\frac{0.10}{0.40} = \frac{[0.30]^y}{[0.60]^y}$$

$$\frac{1}{4} = \left[\frac{1}{2}\right]^y$$

$$\left[\frac{1}{2}\right]^{-2} = \left[\frac{1}{2}\right]^y$$

$$y = 2$$

$$\text{Rate of exp.1} = \frac{[0.30]^x [0.30]^y}{[0.60]^x [0.30]^y}$$

$$\text{Rate of exp.3} = \frac{[0.30]^x [0.30]^y}{[0.60]^x [0.30]^y}$$

$$\frac{0.10}{0.20} = \left[\frac{0.30}{0.60}\right]^x \left[\frac{0.30}{0.30}\right]^y$$

$$\frac{1}{2} = \left[\frac{1}{2}\right]^x [1]^y$$

$$\frac{1}{2} = \left[\frac{1}{2}\right]^x$$

$$x = 1$$

$$\text{Rate} = k[A]^x [B]^y$$

$$\text{Rate} = k[A]^1 [B]^2$$

*i.e.,*

$\therefore$

**Q. 18** Which of the following statement is not correct for the catalyst?

(a) It catalyses the forward and backward reactions to the same extent

(b) It alters  $\Delta G$  of the reaction

(c) It is a substance that does not change the equilibrium constant of a reaction

(d) It provides an alternate mechanism by reducing activation energy between reactants and products

**Ans. (b)** Characteristics of catalyst

- (a) It catalyses the forward and backward reaction to the same extent as it decreases energy of activation hence, increases the rate of both the reactions.
- (b) Since, reaction quotient is the relation between concentration of reactants and products. Hence, catalyst does not alter Gibbs free energy as it is related to reaction quotient. Thus, Gibbs free energy does not change during the reaction when catalyst is added to it.

$$\Delta G = -RT \ln Q$$

where,  $Q$  = reaction quotient

- (c) It doesn't alter equilibrium of reaction as equilibrium constant is also concentration dependent term.
- (d) It provides an alternate mechanism by reducing activation energy between reactants and products.

**Q. 19** The value of rate constant of a pseudo first order reaction .....

- (a) depends on the concentration of reactants present in small amount
- (b) depends on the concentration of reactants present in excess
- (c) is independent of the concentration of reactants
- (d) depends only on temperature

**Ans. (a, b)** Pseudo first order reaction is a chemical reaction in which rate of reaction depends upon concentration of only one reactant while concentration of another reactant has no effect on rate of reaction.

e.g., hydrolysis of ethyl acetate in presence of excess of water

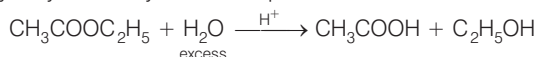

$$r = k [\text{CH}_3\text{COO C}_2\text{H}_5]^2 [\text{H}_2\text{O}]^0$$

Excess  $[\text{H}_2\text{O}]$  can cause the independency of reaction on  $\text{H}_2\text{O}$ .

Hence, (a) is the correct choice.

**Q. 20** Consider the reaction  $\text{A} \longrightarrow \text{B}$ . The concentration of both the reactants and the products varies exponentially with time. Which of the following figures correctly describes the change in concentration of reactants and products with time?

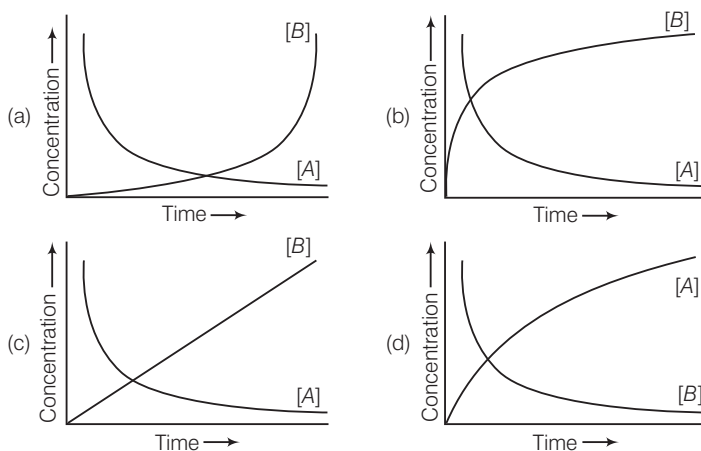

**Ans. (b)**  $A \longrightarrow B$

Concentration of reactants and products varies exponentially *w.r.t* time.

- (i) Concentration of reactant (here,  $A$ ) decreases exponentially *w.r.t* time.
- (ii) Concentration of product (here,  $B$ ) increases exponentially *w.r.t* time new line correct graph representing the above reaction is (b).

## Multiple Choice Questions (More Than One Options)

**Q. 21** Rate law cannot be determined from balanced chemical equation if .....

- (a) reverse reaction is involved
- (b) it is an elementary reaction
- (c) it is a sequence of elementary reactions
- (d) any of the reactants is in excess

**Ans. (a, c, d)**

Rate law can be determined from balanced chemical equation if it is an elementary reaction.

**Q. 22** Which of the following statements are applicable to a balanced chemical equation of an elementary reaction?

- (a) Order is same as molecularity
- (b) Order is less than the molecularity
- (c) Order is greater than the molecularity
- (d) Molecularity can never be zero

**Ans. (a, d)**

For a balanced chemical equation of an elementary reaction order is same as molecularity and molecularity can never be zero. If molecularity of a reaction is considered to be zero it mean that no reactant is going to transform into product. Consider a chemical reaction.

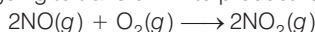

Differential rate law expression can be written as

$$\frac{dR}{dt} = k[\text{NO}]^2 [\text{O}_2]$$

Here, molecularity = 3, order = 3

**Q. 23** In any unimolecular reaction .....

- (a) only one reacting species is involved in the rate determining step
- (b) the order and the molecularity of slowest step are equal to one
- (c) the molecularity of the reaction is one and order is zero
- (d) both molecularity and order of the reaction are one

**Ans. (a, b)**

Since, the reaction is an unimolecular reaction. Hence, in the slowest step *i.e.*, in the rate determining step the only one reacting species is involved. Therefore, order of reaction and molecularity of reaction is equal to one.

**Q. 24** For a complex reaction .....

- (a) order of overall reaction is same as molecularity of the slowest step
- (b) order of overall reaction is less than the molecularity of the slowest step
- (c) order of overall reaction is greater than molecularity of the slowest step
- (d) molecularity of the slowest step is never zero or non-integer

**Ans. (a, d)**

- (a) For a complex reaction, order of overall reaction = molecularity of slowest step  
As rate of overall reaction depends upon total number of molecules involved in slowest step of the reaction. Hence, molecularity of the slowest step is equal to order of overall reaction.
- (d) Since, the completion of any chemical reaction is not possible in the absence of reactants. Hence, slowest step of any chemical reaction must contain at least one reactant. Thus, molecularity of the slowest step is never zero or non-integer.

**Q. 25** At high pressure the following reaction is zero order.

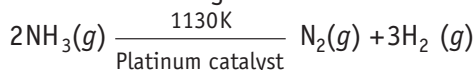

Which of the following options are correct for this reaction?

- (a) Rate of reaction = Rate constant  
(b) Rate of the reaction depends on concentration of ammonia  
(c) Rate of decomposition of ammonia will remain constant until ammonia disappears completely  
(d) Further increase in pressure will change the rate of reaction

**Ans. (a, c, d)**

Given, chemical reaction is



At very high pressure reaction become independent of concentration of ammonia *i.e.*, zero order reaction

Hence,

$$\text{Rate} = k[\rho_{\text{NH}_3}]^0$$

$$\text{Rate} = k$$

- (a) Rate of reaction = Rate constant  
(b) Rate of decomposition of ammonia will remain constant until ammonia disappears completely.  
(c) Since, formation of ammonia is a reversible process further increase in pressure will change the rate of reaction. According to Le-Chatelier principle increase in pressure will favour in backward reaction.

**Q. 26** During decomposition of an activated complex

- (a) energy is always released                      (b) energy is always absorbed  
(c) energy does not change                        (d) reactants may be formed

**Ans. (a, d)**

When the reactant molecules collide each other they lead to formation of an activated complex. It has highest energy among reactants, products and activated complex. When it decomposes to give product, energy is released and stability of product increases.

Since, the entire concentration of activated complex do not convert into products while, some activated complex may give reactants also.

**Q. 27** According to Maxwell, Boltzmann distribution of energy,..... .

- (a) the fraction of molecules with most probable kinetic energy decreases at higher temperatures  
(b) the fraction of molecules with most probable kinetic energy increases at higher temperatures  
(c) most probable kinetic energy increases at higher temperatures  
(d) most probable kinetic energy decreases at higher temperatures

Ans. (a, c)

Distribution of kinetic energy may be described by plotting a graph of fraction of molecules versus kinetic energy.

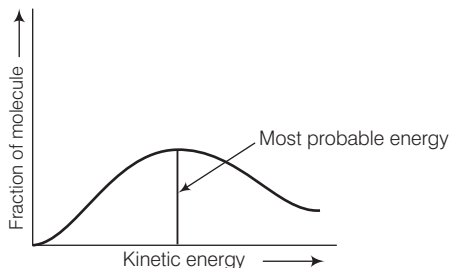

Kinetic energy of maximum fraction of molecule is known as most probable kinetic energy. It is important to note that with increase of temperature, peak shifts forward but downward. This means that with increase of temperature,

- (i) most probable kinetic energy increases.
- (ii) the fractions of molecules possessing most probable kinetic energy decreases.

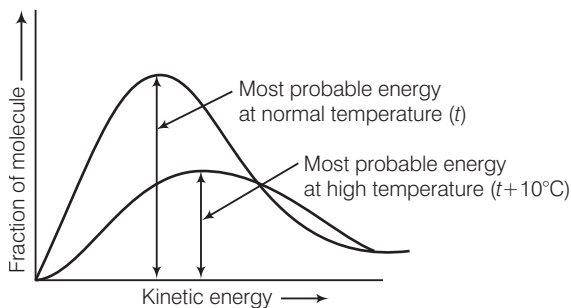

Q. 28 In the graph showing Maxwell, Boltzmann distribution of energy .....

- (a) area under the curve must not change with increase in temperature
- (b) area under the curve increases with increase in temperature
- (c) area under the curve decreases with increase in temperature
- (d) with increase in temperature curve broadens and shifts to the right hand side

Ans. (a, d)

According to Maxwell Boltzmann distribution curve, area under the curve must not change with increase in temperature. But with increase in temperature curve broadens and shift towards right hand side due to decrease in fraction of molecules having most probable kinetic energy.

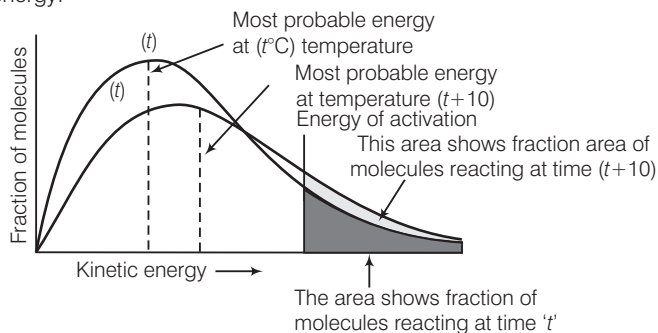

**Q. 29** Which of the following statements are in accordance with the Arrhenius equation?

- (a) Rate of a reaction increases with increase in temperature
- (b) Rate of a reaction increases with decrease in activation energy
- (c) Rate constant decreases exponentially with increase in temperature
- (d) Rate of reaction decreases with decrease in activation energy

**Ans. (a, b)**

Arrhenius equation can be written as  $k = A.e^{\frac{-E_a}{RT}}$

$k \propto e^{-E_a}$  i.e., rate of reaction increases with decrease in activation energy.

$$k \propto e^{\frac{1}{T}}$$

$k \propto e^T$  i.e., rate of reaction increases with increase in temperature.

**Q. 30** Mark the incorrect statements.

- (a) Catalyst provides an alternative pathway to reaction mechanism
- (b) Catalyst raises the activation energy
- (c) Catalyst lowers the activation energy
- (d) Catalyst alters enthalpy change of the reaction

**Ans. (b, d)**

**Function of Catalyst** As the catalyst is added to the reaction medium rate of reaction increases by decreasing activation energy of molecule. Hence, it follows an alternative pathway.

Catalyst does not change the enthalpy change of reaction. Energy of reactant and product remain same in both catalysed and uncatalysed reaction.

Hence, (a) and (d) are incorrect statements.

**Q. 31** Which of the following graphs is correct for a zero order reaction?

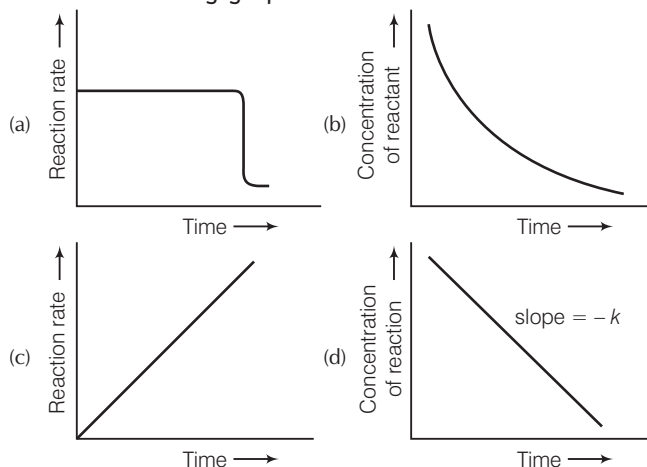

**Thinking Process**

This problem includes graphical representation of zero order reaction. To solve this problem.

- (i) Write rate equation of zero order reaction.
- (ii) Transform it into equation of straight line.
- (iii) Transform it into a curve representing rate versus time.

Ans. (a, d)

For a zero order reaction

$$[R] = (-k)t + [R]_0 \quad \dots(i)$$

$$y = m \times x + c$$

On comparing with Eq. of straight line

$$y = [R] \text{ concentration}$$

$$x = t \text{ time}$$

$$\text{Slope (m)} = -k \text{ rate constant}$$

$$\text{Intercept (c)} = [R]_0 \text{ initial concentration}$$

On rearranging Eq. (i)

$$\frac{[R] - [R]_0}{t} = -k$$

$$\frac{[R] - [R]_0}{t} = -kt^0$$

$$\text{Rate} \propto t^0$$

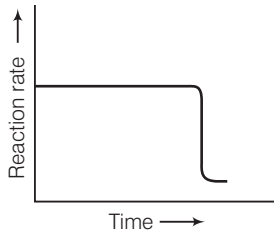
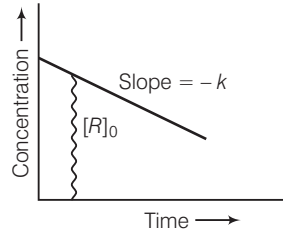

Q. 32 Which of the following graphs is correct for a first order reaction?

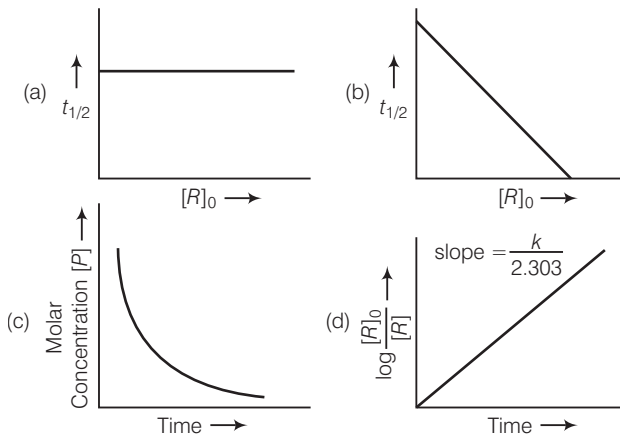

Ans. (a, d)

For the first order reaction

$$k = \frac{2.303}{t} \log \frac{[R]_0}{[R]}$$

$$\frac{kt}{2.303} = \log \frac{[R]_0}{[R]}$$

$$\log \frac{[R]_0}{[R]} = \left( \frac{k}{2.303} \right) \times t + 0$$

$$\begin{matrix} \uparrow & \uparrow & \uparrow & \uparrow \\ y = & m & x + c \end{matrix}$$



Correct plot of  $\log \frac{[R]_0}{[R]}$  can be represented by (d)

where,  $\text{slope} = \frac{k}{2.303}$

The time taken for any fraction of the reaction to complete is independent of the initial concentration. Let, us consider it for half of the reaction to complete.

$$t = \frac{2.303}{k} \log \frac{a}{a-x}$$

For half-life

$$t = t_{1/2} \text{ and } x = \frac{a}{2}$$

$$t_{1/2} = \frac{2.303}{k} \log \frac{a}{a - \frac{a}{2}}$$

$$t_{1/2} = \frac{2.303}{k} \log 2$$

Half-life time

$$t_{1/2} = \frac{0.693}{k}$$

$t_{1/2}$  is independent of initial concentration. Hence, correct plot of  $t_{1/2}$  and  $[R]_0$  can be represented by a.

## Short Answer Type Questions

**Q. 33** State a condition under which a bimolecular reaction is kinetically first order reaction.

**Ans.** Presence of one of the reactants in excess, as in such a condition, its concentration remains constant and rate of such reaction depends upon concentration of one reactant only and reaction is known as pseudo first order reaction e.g., acid catalysed hydrolysis of ethyl acetate.

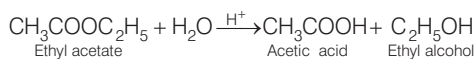

This reaction is bimolecular but is found to be of first order as experimentally it is observed that rate of reaction depends upon the concentration of ethyl acetate not on water as it is present in excess.

**Q. 34** Write the rate equation for the reaction  $2A + B \longrightarrow C$  if the order of the reaction is zero.

**Ans.** For reaction  $2A + B \longrightarrow C$  if the rate of reaction is zero then it can be represented as

$$\text{Rate} = k [A]^0 [B]^0 = k$$

i.e., rate of reaction is independent of concentration of A and B.

**Q. 35** How can you determine the rate law of the following reaction?

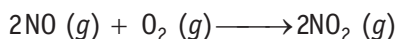

**Ans.** We can determine the rate of this reaction as a function of initial concentrations either by keeping the concentration of one of the reactants constant and changing the concentration of the other reactant or by changing the concentration of both the reactants. e.g., for the given reaction,

(i) Keeping  $[\text{O}_2]$  constant, if the concentration of NO is doubled, rate is found to become four times. This shows that,

$$\text{Rate} \propto [\text{NO}]^2$$

(ii) Keeping [NO] constant, if the concentration of  $[\text{O}_2]$  is doubled, rate is also found to become double. This shows that,

$$\text{Rate} \propto [\text{O}_2]^2$$

Hence, overall rate law will be

$$\text{Rate} = k[\text{NO}]^2 [\text{O}_2]$$

$$\begin{aligned} \text{Rate law expression} \quad -\frac{1}{2} \frac{\Delta[\text{NO}]}{\Delta t} &= -\frac{\Delta[\text{O}_2]}{\Delta t} \\ &= \frac{1}{2} \frac{\Delta[\text{NO}_2]}{\Delta t} \end{aligned}$$

**Q. 36** For which type of reactions, order and molecularity have the same value?

**Ans.** If the reaction is elementary reaction then order and molecularity have same value because elementary reaction proceeds in a single step.

**Q. 37** In a reaction if the concentration of reactant A is tripled, the rate of reaction becomes twenty seven times. What is the order of the reaction?

**Ans.** Rate of any elementary reaction can be represented as

$$r = k[A]^n$$

After changing concentration to its triple value  $A = 3A$ ,  $r$  becomes  $27r$

$$27r = k[3A]^n$$

$$\frac{r}{27r} = \frac{k[A]^n}{k[3A]^n}$$

$$\frac{1}{27} = \left[\frac{1}{3}\right]^n \Rightarrow \left[\frac{1}{3}\right]^3 = \left[\frac{1}{3}\right]^n$$

Hence,  $n = 3$

Order of reaction is three.

**Q. 38** Derive an expression to calculate time required for completion of zero order reaction.

**Ans.** For zero order reaction  $[R] = [R]_0 - kt$   
For completion of the reaction  $[R] = 0$

$$\therefore t = \frac{[R]_0}{k}$$

**Q. 39** For a reaction  $A + B \longrightarrow \text{Products}$ , the rate law is  $\text{Rate} = k[A][B]^{3/2}$ .  
Can the reaction be an elementary reaction? Explain.

**Ans.** During an elementary reaction, the number of atoms or ions colliding to react is referred to as molecularity. Had this been an elementary reaction, the order of reaction with respect to  $B$  would have been 1, but in the given rate law it is  $\frac{3}{2}$ . This indicates that the reaction is not an elementary reaction. Hence, this reaction must be a complex reaction.

**Q. 40** For a certain reaction large fraction of molecules has energy more than the threshold energy, yet the rate of reaction is very slow. Why?

**Ans.** According to collision theory apart from the energy considerations, the colliding molecules should also have proper orientation for effective collision. This condition might not be getting fulfilled in the reaction as it shows the number of reactants taking part in a reaction, which can never be zero.

**Q. 41** For a zero order reaction will the molecularity be equal to zero? Explain.

**Ans.** No, the molecularity can never be zero or a fractional number as it shows the number of reactants taking part in a reaction which can never be zero.

**Q. 42** For a general reaction  $A \rightarrow B$ , plot of concentration of  $A$  vs time is given in figure. Answer the following questions on the basis of this graph.

- What is the order of the reaction?
- What is the slope of the curve?
- What are the units of rate constant?

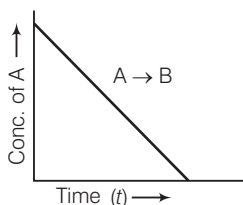

**Ans.** (i) For  $A \longrightarrow B$  the given graph shows a zero order reaction. Mathematically represented as

$$[R] = -kt + [R]_0$$

Which is equation of straight line. Hence, reaction is a zero order.

- Slope =  $-k$
- Unit of zero order reaction is  $\text{mole L}^{-1} \text{s}^{-1}$ .

**Q. 43** The reaction between  $\text{H}_2(g)$  and  $\text{O}_2(g)$  is highly feasible yet allowing the gases to stand at room temperature in the same vessel does not lead to the formation of water. Explain.

**Ans.** Because activation energy of the reaction is very high at room temperature but at high temperature  $\text{H}-\text{H}$  and  $\text{O}-\text{O}$  bond break and colliding particles cross the energy barrier. This is why reaction between  $\text{H}_2(g)$  and  $\text{O}_2(g)$  does not lead to formation of water at room temperature while keeping in the same vessel.

**Q. 44** Why does the rate of a reaction increase with rise in temperature?

**Ans.** At higher temperatures, larger fraction of colliding particles can cross the energy barrier (*i.e.*, the activation energy) which leads to faster rate.

**Q. 45** Oxygen is available in plenty in air yet fuels do not burn by themselves at room temperature. Explain.

**Ans.** For combustion reactions, activation energy of fuels is very high at room temperature. So, fuels do not burn by themselves at room temperature.

**Q. 46** What is the probability of reaction with molecularity higher than three very rare?

**Ans.** According to collision theory, we know that to complete any chemical reaction there must be effective collision between reactant particles and they must have minimum sufficient energy. The probability of more than three molecules colliding simultaneously is very small. Hence, possibility of molecularity being three is very low.

**Q. 47** Why does the rate of any reaction generally decreases during the course of the reaction?

**Ans.** The rate of a reaction depends on the concentration of the reactants. As the reaction proceeds in forward direction, concentration of reactant decreases and that of products increases. So, the rate of reaction generally decreases during the course of reaction.

**Q. 48** Thermodynamic feasibility of the reaction alone cannot decide the rate of the reaction. Explain with the help of one example.

**Ans.** Thermodynamically the conversion of diamond to graphite is highly feasible but this reaction is very slow because its activation energy is high.  
Hence, thermodynamic feasibility of the reaction alone cannot decide the rate of reaction.

**Q. 49** Why in the redox titration of  $\text{KMnO}_4$  vs oxalic acid, we heat oxalic acid solution before starting the titration?

**Ans.** As we know with increase in temperature rate of reaction increases, Hence, we heat oxalic acid solution before starting of titration to increase the rate of decolourisation.

**Q. 50** Why can't molecularity of any reaction be equal to zero?

**Ans.** Molecularity of the reaction is the number of molecules taking part in an elementary step. For this we require at least a single molecule leading to the value of minimum molecularity of one. Hence, molecularity of any reaction can never be equal to zero.

**Q. 51** Why molecularity is applicable only for elementary reactions and order is applicable for elementary as well as complex reactions?

**Ans.** A complex reaction occurs through a number of steps *i.e.*, elementary reactions. Number of molecules involved in each elementary reaction may be different, *i.e.*, the molecularity of each step may be different. Therefore, it is meaningless to talk of molecularity of the overall complex reaction.

On the other hand, order of complex reaction depends upon the molecularity of the slowest step. Hence, it is not meaningless to talk of the order of a complex reaction.

**Q. 52** Why can we not determine the order of a reaction by taking into consideration the balanced chemical equation?

**Ans.** Balanced chemical equation often leads to incorrect order or rate law. e.g., the following reaction seems to be a tenth order reaction

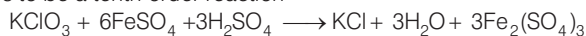

This is actually a second order reaction. Actually the reaction is complex and occurs in several steps. The order of such reaction is determined by the slowest step in the reaction mechanism.

Order is determined experimentally and is confined to the dependence of observed rate of reaction on the concentration of reactants.

## Matching The Columns

**Q. 53** Match the graph given in Column I with the order of reaction given in Column II. More than one item in Column I may link to the same item of Column II.

	Column I	Column II
A.		1. First order
B.		
C.		2. Zero order
D.		

Ans. A. →(1) B. →(2) C. →(2) D. →(1)

For zero order reaction rate equation may be written as

$$[R] = -kt + [R_0] \quad \dots(i)$$

Which denotes a straight line equation similar to  $y = mx + c$

On transforming (i)  $\frac{[R] - [R_0]}{t} = -k$

$$k = \frac{[R_0] - [R]}{t}$$

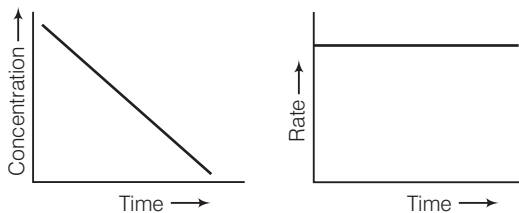

$$k = \text{Rate}$$

$$\text{Rate} = k \cdot [t]^0$$

$$\text{Rate} \propto [t]^0$$

For a first order reaction  $\frac{dx}{dt} \propto [\text{concentration}]^1$

∴ Graph between rate and concentration may be drawn as

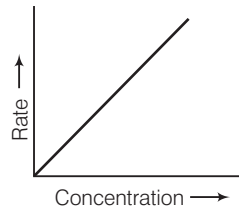

$$k = \frac{2.303}{t} \log \frac{[R]_0}{[R]}$$

$$\frac{kt}{2.303} = \log \left[ \frac{[R]_0}{[R]} \right]$$

$$\frac{kt}{2.303} = \log [R]_0 - \log [R]$$

$$\log [R] = \left( \frac{-k}{2.303} \right) t + \log [R]_0$$

Slope       Intercept

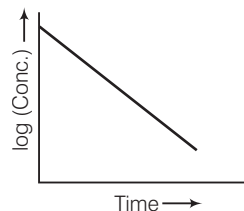

Q. 54 Match the statements given in Column I and Column II.

Column I	Column II
A. Catalyst alters the rate of reaction	1. Cannot be fraction or zero
B. Molecularity	2. Proper orientation is not there
C. Second half-life of first order reaction	3. By lowering the activation energy
D. $e^{-E_a/RT}$	4. Is same as the first
E. Energetically favourable reactions are sometimes slow	5. Total probability is one
F. Area under the Maxwell, Boltzmann curve is constant	6. Refers to the fraction of molecules with energy equal to or greater than activation energy

**Ans.** A. → (3) B. → (1) C. → (4) D. → (6) E. → (2) F. → (5)

1. Catalyst alters the rate of reaction by lowering activation energy.
2. Molecularity can't be fraction or zero. If molecularity is zero, then reaction is not possible.
3. Second half-life of first order reaction is same as first because half-life time is temperature independent.
4.  $e^{-E_a/RT}$  refers to the fraction of molecules with kinetic energy equal to or greater than activation energy.
5. Energetically favourable reactions are sometimes slow due to improper orientation of molecule cause some ineffective collision of molecules.
6. Area under the Maxwell, Boltzmann curve is constant because total probability of molecule taking part in a chemical reaction is equal to one.

**Q. 55** Match the items of Column I and Column II.

Column I	Column II
A. Diamond	1. Short interval of time
B. Instantaneous rate	2. Ordinarily rate of conversion is imperceptible
C. Average rate	3. Long duration of time

**Ans.** A. → (2) B. → (1) C. → (3)

1. Diamond can't be converted into graphite under ordinary condition.
2. Instantaneous rate of reaction completes at very short span of time.
3. Average rate of reaction occurs to a long duration of time.

**Q. 56** Match the items of Column I and Column II.

Column I	Column II
A. Mathematical expression for rate of reaction	1. Rate constant
B. Rate of reaction for zero order reaction is equal to	2. Rate law
C. Units of rate constant for zero order reaction is same as that of	3. Order of slowest step
D. Order of a complex reaction is determined by	4. Rate of reaction

**Ans.** A. → (2) B → (1) C → (4) D → (3)

1. Mathematical expression for rate of reaction is known as rate law.
2. Rate of reaction for zero order reaction is equal to rate constant  

$$r = k[A]^0$$

$$\therefore r = k$$
3. Unit of rate of reaction is same as that of rate of reaction.
4. Order of complex reaction is determined by rate of a reaction, which is slowest.

## Assertion and Reason

*In the following questions a statement of Assertion (A) followed by a statement of Reason (R) is given. Choose the correct answer out of the following choices.*

- (a) Both assertion and reason are correct and the reason is correct explanation of assertion.
- (b) Both assertion and reason are correct, but reason does not explain assertion.
- (c) Assertion is correct, but reason is incorrect.
- (d) Both assertion and reason are incorrect.
- (e) Assertion is incorrect, but reason is correct.

**Q. 57** Assertion (A) Order of the reaction can be zero or fractional.

Reason (R) We cannot determine order from balanced chemical equation.

**Ans. (b)** Both assertion and reason are correct, but the reason is not the correct explanation of assertion.

Order of reaction can be zero or fractional as order of reaction is directly related to sum of power of reactants. Reason is a correct statement but not correct explanation.

**Q. 58** Assertion (A) Order and molecularity are same.

Reason (R) Order is determined experimentally and molecularity is the sum of the stoichiometric coefficient of rate determining elementary step.

**Ans. (e)** Assertion is incorrect and reason is correct.

Order and molecularity may or may not be same as order of reaction is sum of power of reactant which can be determined experimentally. But molecularity is sum of stoichiometric coefficient of rate determining elementary step.

**Q. 59** Assertion (A) The enthalpy of reaction remains constant in the presence of a catalyst.

Reason (R) A catalyst participating in the reaction forms different activated complex and lowers down the activation energy but the difference in energy of reactant and product remains the same.

**Ans. (a)** Assertion and reason both are correct and reason is the correct explanation of assertion.

Enthalpy of reaction *i.e.*, difference of total enthalpy of reactants and product remains constant in the presence of a catalyst. As a catalyst participating in the reaction forms different activated complex and lowers down the activation energy but the difference in energy of reactant and product remains same.

**Q. 60** Assertion (A) All collision of reactant molecules lead to product formation.

Reason (R) Only those collisions in which molecules have correct orientation and sufficient kinetic energy lead to compound formation.

**Ans. (e)** Assertion is incorrect, but reason is correct.

Correct assertion is "only effective collision lead to formation of product." Reason defines correct meaning of effective collision, and criterion of collision theory for completion of reaction.

Only those collisions in which molecules have correct orientation and sufficient energy lead to formation of product.



- Q. 61** Assertion (A) Rate constant determined from Arrhenius equation are fairly accurate for simple as well as complex molecules.  
Reason (R) Reactant molecules undergo chemical change irrespective of their orientation during collision.

**Ans. (c)** Assertion is correct, but reason is incorrect.

Rate constant determined from Arrhenius equation are fairly accurate for simple and complex molecules because only those molecules which have proper orientation during collision (*i.e.*, effective collision) and sufficient kinetic energy lead the chemical change.

## Long Answer Type Questions

- Q. 62** All energetically effective collisions do not result in a chemical change. Explain with the help of an example.

**Ans.** Only effective collision lead to the formation of products. It means that collisions in which molecules collide with sufficient kinetic energy (called threshold energy = activation energy + energy possessed by reacting species).

And proper orientation lead to a chemical change because it facilitates the breaking of old bonds between (reactant) molecules and formation of the new ones *i.e.*, in products.

*e.g.*, formation of methanol from bromomethane depends upon the orientation of the reactant molecules.

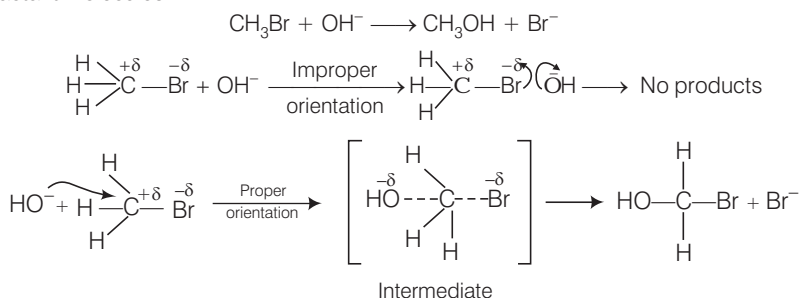

The proper orientation of reactant molecules leads to bond formation whereas improper orientation makes them simply back and no products are formed.

To account for effective collisions, another factor  $P$  (probability or steric factor) is introduced  
 $K = PZ_{AB}e^{-E_a/RT}$ .

- Q. 63** What happens to most probable kinetic energy and the energy of activation with increase in temperature?

**Ans.** Kinetic energy is directly proportional to the absolute temperature and the number of molecules possessing higher energies increases with increase in temperature, *i.e.*, most probable kinetic energy increases with increase in temperature.

Energy of activation is related to temperature by the following Arrhenius equation

$$k = Ae^{-E_a/RT}$$

Thus, it also shows an increase with rise in temperature.

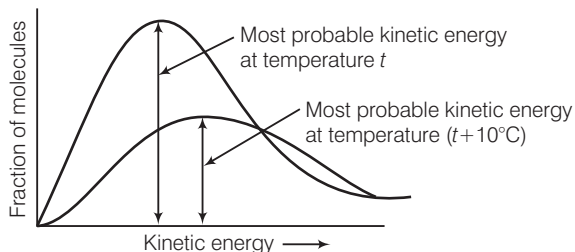

**Q. 64** Describe how does the enthalpy of reaction remain unchanged when a catalyst is used in the reaction?

**Ans.** A catalyst is a substance which increases the speed of a reaction without itself undergoing any chemical change.

According to "intermediate complex formation theory" reactants first combine with the catalyst to form an intermediate complex which is short-lived and decomposes to form the products and regenerating the catalyst.

The intermediate formed has much lower potential energy than the intermediate complex formed between the reactants in the absence of the catalyst.

Thus, the presence of catalyst lowers the potential energy barrier and the reaction follows a new alternate pathway which require less activation energy.

We know that, lower the activation energy, faster is the reaction because more reactant molecules can cross the energy barrier and change into products.

Enthalpy,  $\Delta H$  is a state function. Enthalpy of reaction, i.e., difference in energy between reactants and product is constant, which is clear from potential energy diagram.

Potential energy diagram of catalysed reaction is given as

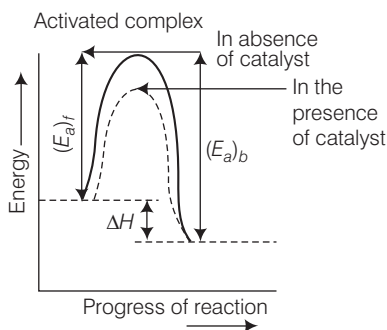

**Q. 65** Explain the difference between instantaneous rate of a reaction and average rate of a reaction.

**Ans.** The difference between instantaneous rate of reaction and average rate of a reaction are as below

	Instantaneous rate of reaction	Average rate of reaction
(i)	It occurs within a short span of time.	It occurs during a long interval of time.
(ii)	It can't be calculated for multistep reaction.	It can be calculated for multistep reaction.
(iii)	It can be calculated for elementary reaction.	It can be calculated for elementary reaction.

**Q. 66** With the help of an example explain what is meant by pseudo first order reaction.

**Ans.** A reaction in which one reactant is present in large amount and its concentration does not get altered during the course of the reaction, behaves as first order reaction. Such reaction is called pseudo first order reaction.

e.g., (i) hydrolysis of ethyl acetate

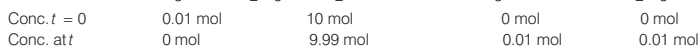
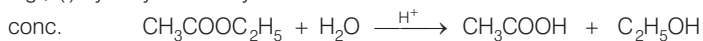

$$\text{Rate of reaction} = k [\text{CH}_3\text{COOC}_2\text{H}_5]$$

where,  $k = k' [\text{H}_2\text{O}]$

e.g., (ii) inversion of cane sugar

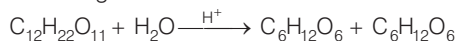

$$\text{Rate of reaction} = k [\text{C}_{12}\text{H}_{22}\text{O}_{11}]$$

where  $k = k' [\text{H}_2\text{O}]$

# 5

## Surface Chemistry

### Multiple Choice Questions (MCQs)

**Q. 1** Which of the following process does not occur at the interface of phases?

- (a) Crystallisation (b) Heterogeneous catalysis  
(c) Homogeneous catalysis (d) Corrosion

**Ans. (c)** Homogeneous catalysis does not occur at the interface of phases as in case of homogeneous catalysis reactant and catalyst have same phase and their distribution is uniform throughout.

**Q. 2** At the equilibrium position in the process of adsorption .....

- (a)  $\Delta H > 0$  (b)  $\Delta H = T\Delta S$  (c)  $\Delta H > T\Delta S$  (d)  $\Delta H < T\Delta S$

**Ans. (b)** As we know that, at equilibrium  $\Delta G = 0$

$$\Delta H - T\Delta S = 0$$

$$\Delta H = T\Delta S$$

Hence, at equilibrium enthalpy change is equal to product of temperature and entropy change.

**Q. 3** Which of the following interface cannot be obtained?

- (a) Liquid-liquid (b) Solid-liquid  
(c) Liquid-gas (d) Gas-gas

**Ans. (d)** Gas-gas interface can not be obtained as they are completely miscible in nature. e.g., air is a mixture of various gases such as,  $O_2$ ,  $N_2$ ,  $CO_2$  etc.

**Q. 4** The term 'sorption' stands for .....

- (a) absorption (b) adsorption  
(c) Both absorption and adsorption (d) desorption

**Ans. (c)** Sorption stands for both absorption and adsorption. We can understand this by using following figures

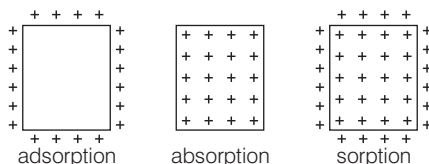

**Q. 5** Extent of physisorption of a gas increases with .....

- (a) increase in temperature
- (b) decrease in temperature
- (c) decrease in surface area of adsorbent
- (d) decrease in strength of van der Waals' forces

**Ans. (b)** Extent of physisorption of a gas increases with decrease in temperature. Because in physisorption particles are held to the surface by weak van der Waals' force of attraction hence on increasing temperature they get desorbed easily.

**Q. 6** Extent of adsorption of adsorbate from solution phase increases with .....

- (a) increase in amount of adsorbate in solution
- (b) decrease in surface area of adsorbent
- (c) increase in temperature of solution
- (d) decrease in amount of adsorbate in solution

**Ans. (a)** Extent of adsorption of adsorbate from solution phase increases with increase in amount of adsorbate in solution. As amount of adsorbate in the solution increases interaction of adsorbate with adsorbent increases which lead to increase in extent of adsorption.

**Q. 7** Which one of the following is not applicable to the phenomenon of adsorption?

- (a)  $\Delta H > 0$
- (b)  $\Delta G < 0$
- (c)  $\Delta S < 0$
- (d)  $\Delta H < 0$

**Ans. (a)** For phenomenon of adsorption  $\Delta H < 0$ , i.e., enthalpy change during phenomenon of adsorption is negative because during adsorption, there is always a decrease in residual forces of the surface which lead to decrease in surface energy which appears as heat.

So, adsorption is an exothermic process and  $\Delta H < 0$ .

**Q. 8** Which of the following is not a favourable condition for physical adsorption?

- (a) High pressure
- (b) Negative  $\Delta H$
- (c) Higher critical temperature of adsorbate
- (d) High temperature

**Ans. (d)** Physisorption is a process in which adsorbate get adsorbed on the adsorbent surface by weak van der Waals' force of attraction. On increasing temperature the interaction between adsorbate and adsorbent becomes weak and adsorbate particles get desorbed.

**Q. 9** Physical adsorption of a gaseous species may change to chemical adsorption with .....

- (a) decrease in temperature
- (b) increase in temperature
- (c) increase in surface area of adsorbent
- (d) decrease in surface area of adsorbent

**Ans. (b)** On increasing temperature physisorption changes to chemisorption. As temperature increases, energy of activation of adsorbate particles increases which lead to formation of chemical bond between adsorbate and adsorbent.

Hence, physisorption transform into chemisorption.

**Q. 10** In physisorption adsorbent does not show specificity for any particular gas because .....

- (a) involved van der Waals' forces are universal  
 (b) gases involved behave like ideal gases  
 (c) enthalpy of adsorption is low  
 (d) it is a reversible process

**Ans. (a)** In physisorption adsorbent does not show specificity for any particular gas because involved van der Waals' forces are universal. It means extent of van der Waals' interaction between adsorbate and adsorbent is constant for all gases.

**Q. 11** Which of the following is an example of absorption?

- (a) Water on silica gel (b) Water on calcium chloride  
 (c) Hydrogen on finely divided nickel (d) Oxygen on metal surface

**Ans. (b)** Absorption means penetration of adsorbate molecules into the bulk of the adsorbent e.g., water on calcium chloride. When water is spread over calcium chloride, water get penetrate into bulk of the calcium chloride.

**Q. 12** On the basis of data given below predict which of the following gases shows least adsorption on a definite amount of charcoal?

Gas	CO <sub>2</sub>	SO <sub>2</sub>	CH <sub>4</sub>	H <sub>2</sub>
Critical temp./K	304	630	190	33

- (a) CO<sub>2</sub> (b) SO<sub>2</sub> (c) CH<sub>4</sub> (d) H<sub>2</sub>

🔍 **Thinking Process**

*This problem includes concept of extent of conjugation and critical temperature. Extent of adsorption is directly related to critical temperature of gases.*

**Ans. (d)** Lesser the value of critical temperature of gases lesser will be the extent of adsorption. Here H<sub>2</sub> has lowest value of critical temperature, i.e., 33. Hence, hydrogen gas shows least adsorption on a definite amount of charcoal.

**Q. 13** In which of the following reactions heterogeneous catalysis is involved?

- (i)  $2\text{SO}_2(g) + \text{O}_2(g) \xrightarrow{\text{NO}(g)} 2\text{SO}_3(g)$   
 (ii)  $2\text{SO}_2(g) \xrightarrow{\text{Pt}(s)} 2\text{SO}_3(g)$   
 (iii)  $\text{N}_2(g) + 3\text{H}_2(g) \xrightarrow{\text{Fe}(s)} 2\text{NH}_3(g)$   
 (iv)  $\text{CH}_3\text{COOCH}_3(l) + \text{H}_2\text{O}(l) \xrightarrow{\text{HCl}(l)} \text{CH}_3\text{COOH}(aq) + \text{CH}_3\text{OH}(aq)$   
 (a) (ii), (iii) (b) (ii), (iii) and (iv) (c) (i), (ii) and (iii) (d) (iv)

**Ans. (c)** (i) Reaction in which catalyst is in different phase than other (reactants and products) is known as heterogeneous catalysis.

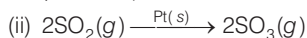

Here, reactant SO<sub>2</sub> and product SO<sub>3</sub> are in gaseous phase while platinum is in solid phase. So, this reaction represents a heterogeneous catalysis.

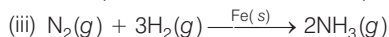

Similarly, here N<sub>2</sub> and H<sub>2</sub> reactants are in gaseous phase while NH<sub>3</sub> is in solid phase. Whereas in other reactions catalyst is in same phase with reactant(s) and product(s).

**Q. 14** At high concentration of soap in water, soap behaves as .....

- (a) molecular colloid (b) associated colloid  
(c) macromolecular colloid (d) lyophilic colloid

**Ans. (b)** **Associated colloid** At high concentration of soap in water, soap particles present in the solution get associated around and lead to formation of associated colloid.

**Q. 15** Which of the following will show Tyndall effect?

- (a) Aqueous solution of soap below critical micelle concentration  
(b) Aqueous solution of soap above critical micelle concentration  
(c) Aqueous solution of sodium chloride  
(d) Aqueous solution of sugar

**Ans. (b)** Aqueous solution of soap above critical micelle concentration lead to formation of colloidal solution. Tyndall effect is a characteristic of colloidal solution in which colloidal particles show a coloured appearance when sunlight is passes through it and seen from the perpendicular side.

**Q. 16** Method by which lyophobic sol can be protected.

- (a) By addition of oppositely charged sol  
(b) By addition of an electrolyte  
(c) By addition of lyophilic sol  
(d) By boiling

**Ans. (c)** Lyophobic sol can be protected by addition of lyophilic sol. As lyophobic sols are readily precipitated on addition of small amount of electrolytes or shaking, or heating hence they are made stable by adding lyophilic sol which stabilises the lyophobic sols.

**Q. 17** Freshly prepared precipitate sometimes gets converted to colloidal solution by .....

- (a) coagulation (b) electrolysis (c) diffusion (d) peptisation

**Ans. (d)** Freshly prepared precipitate sometimes gets converted to colloidal solution by peptisation. Peptisation is a process in which by addition of a suitable peptising agent precipitate gets converted into colloidal solution.

**Q. 18** Which of the following electrolytes will have maximum coagulating value for  $\text{Ag}/\text{Ag}^+$  sol?

- (a)  $\text{Na}_2\text{S}$  (b)  $\text{Na}_3\text{PO}_4$  (c)  $\text{Na}_2\text{SO}_4$  (d)  $\text{NaCl}$

**Thinking Process**

*This problem includes concept of Hardy-Schulze law. According to which higher charge on oppositely charge ion of electrolyte decide the coagulating power of colloid.*

**Ans. (b)** According to Hardy-Schulze law, greater the charge on anion greater will be its coagulating power.

Electrolytes	Anionic part	Charge on anion
$\text{Na}_2\text{S}$	$\text{S}^{2-}$	2
$\text{Na}_3\text{PO}_4$	$\text{PO}_4^{3-}$	3
$\text{Na}_2\text{SO}_4$	$\text{SO}_4^{2-}$	2
$\text{NaCl}$	$\text{Cl}^-$	1

Here,  $\text{PO}_4^{3-}$  have highest charge. Hence,  $\text{PO}_4^{3-}$  have highest coagulating power.

**Q. 19** A colloidal system having a solid substance as a dispersed phase and a liquid as a dispersion medium is classified as .....

- (a) solid sol      (b) gel      (c) emulsion      (d) sol

**Ans. (d)** Sol is a colloidal system in which solid substance is a dispersed phase and a liquid is a dispersion medium. e.g., paint, cell fluids etc.

In paints solid colouring particles are dissolved in liquid dispersion medium.

**Q. 20** The values of colligative properties of colloidal solution are of small order in comparison to those shown by true solutions of same concentration because of colloidal particles .....

- (a) exhibit enormous surface area  
 (b) remain suspended in the dispersion medium  
 (c) form lyophilic colloids  
 (d) are comparatively less in number

**Ans. (d)** The value of colligative properties of colloidal solution are of small order in comparison to those of true solution of same concentration because of colloidal particles are comparatively less in number.

This is due to slight large size of colloidal particles in comparison to particles present in true solution. Size of colloidal particles is in between 1 nm to 1000 nm.

**Q. 21** Arrange the following diagrams in correct sequence of steps involved in the mechanism of catalysis, in accordance with modern adsorption theory.

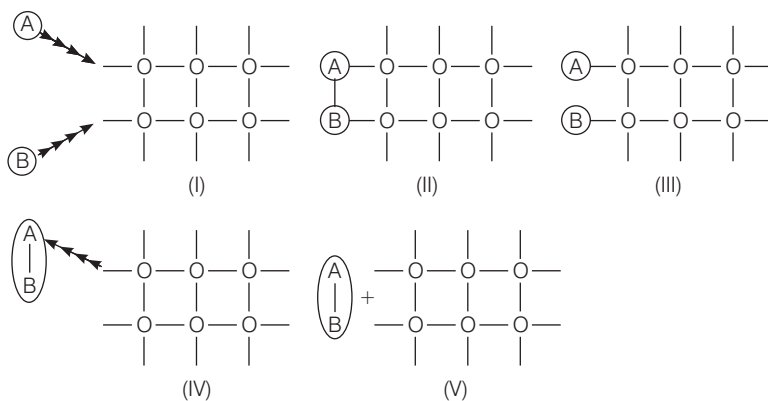

- (a) I → II → III → IV → V  
 (b) I → III → II → IV → V  
 (c) I → III → II → V → IV  
 (d) I → II → III → V → IV

**Ans. (b)** Correct sequence is I → III → II → IV → V

Each transformation denotes a meaningful process as follows

I → adsorption of A and B on surface

III → II interaction between A and B to form intermediate



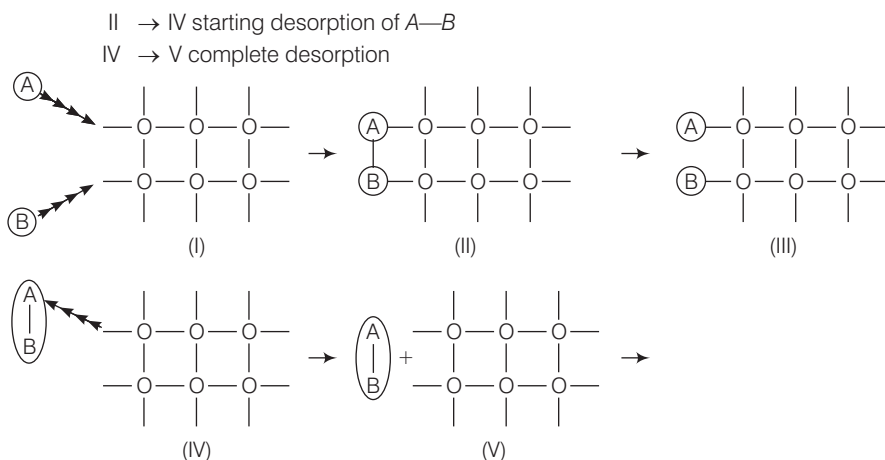

**Q. 22** Which of the following process is responsible for the formation of delta at a place where rivers meet the sea?

- (a) Emulsification (b) Colloid formation  
 (c) Coagulation (d) Peptisation

**Ans. (c)** River water is a colloidal solution of clay and sea water contains various electrolytes. When river water comes in contact with sea water, then the electrolytes present in sea water coagulate the suspended colloidal particles which ultimately settle down at the point of contact.

**Q. 23** Which of the following curves is in accordance with Freundlich adsorption isotherm?

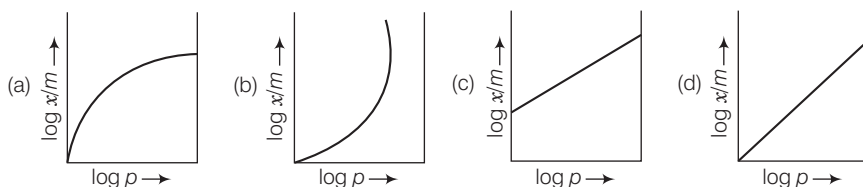

**Ans. (c)** According to the Freundlich adsorption isotherm

$$\frac{x}{m} = kp^n$$

Taking log on both side  $\log \frac{x}{m} = \left(\frac{1}{n}\right) \log p + \log k$

$$\begin{array}{cccc} \uparrow & \uparrow & \uparrow & \uparrow \\ Y & = & m & x + C \end{array}$$

On comparing it with equation of straight line and drawing the graph  $\log \frac{x}{m}$  versus  $\log p$ , we get a straight line with intercept

$\log k$  and slope of the straight line gives the value of  $\frac{1}{n}$ .

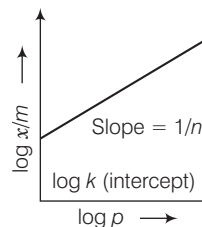

**Q. 24** Which of the following process is not responsible for the presence of electric charge on the sol particles?

- (a) Electron capture by sol particles
- (b) Adsorption of ionic species from solution
- (c) Formation of Helmholtz electrical double layer
- (d) Absorption of ionic species from solution

**Ans. (d)** Absorption of ionic species from solution is not responsible for the presence of electric charge on the sol particles. *Charge on the sol particles is due to*

- (i) electrons capture by sol particles during electro dispersion of metal.
- (ii) preferential adsorption of ionic species from solution.
- (iii) formation of Helmholtz electrical double layer.

**Q. 25** Which of the following phenomenon is applicable to the process shown in the figure?

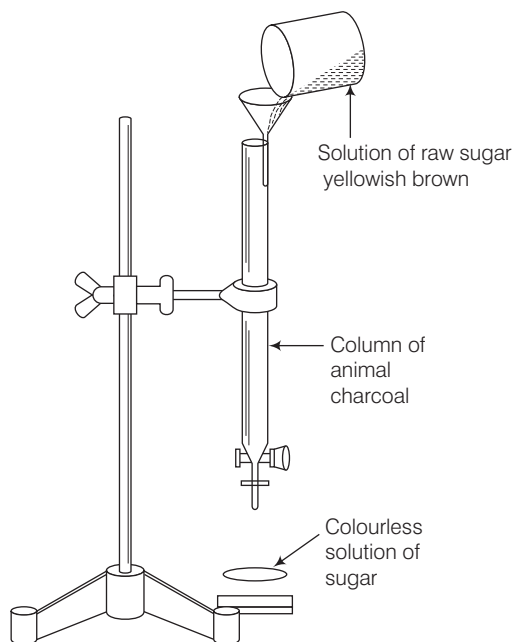

- (a) Absorption
- (b) Adsorption
- (c) Coagulation
- (d) Emulsification

**Ans. (b)** Above figure represent adsorption of yellowish brown colour of raw sugar by animal charcoal.

Here, aqueous solution of raw sugar is filtered by using animal charcoal. Yellowish brown colour of raw sugar is adsorbed and filtrate is colourless which gives white colour on crystallisation. Hence, this phenomenon is adsorption.

## Multiple Choice Questions (More Than One Options)

**Q. 26** Which of the following options are correct?

- (a) Micelle formation by soap in aqueous solution is possible at all temperatures
- (b) Micelle formation by soap in aqueous solution occurs above a particular concentration
- (c) On dilution of soap solution micelles may revert to individual ions
- (d) Soap solution behaves as a normal strong electrolyte at all concentrations

**💡 Thinking Process**

*This problem is based on concept of micelle formation and CMC (critical micelle concentration).*

**Ans. (b, c)**

**Micelle formation** Some substances at low concentration behaves as a normal electrolytes but at higher concentration exhibit colloidal behaviour due to formation of micelles.

**CMC (Critical Micelle Concentration)** The concentration above which it behaves as a micelle known as critical micelle concentration (CMC).

e.g., soap solution in aqueous solution above particular concentration (called CMC =  $10^{-4} - 10^3 \text{ mol L}^{-1}$ ) forms soap micelles.

On dilution soap solution behaves as a normal electrolyte and after adding excess of water intermolecular force of attraction between the soap particles decreases and soap solution micelles may revert to individual ions.

**Q. 27** Which of the following statements are correct about solid catalyst?

- (a) Same reactants may give different products by using different catalysts
- (b) Catalyst does not change  $\Delta H$  of reaction
- (c) Catalyst is required in large quantities to catalyse reactions
- (d) Catalytic activity of a solid catalyst does not depend upon the strength of chemisorption

**Ans. (a, b)**

(a) Same reactants may give different products by using different catalysts as different catalysts have different specific functions to mold the reaction towards specific product.

e.g., starting with  $\text{H}_2$  and  $\text{CO}$ , and using different catalysts, we get different products.

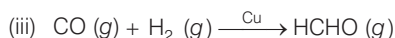
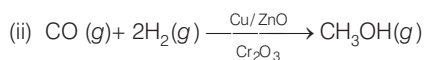
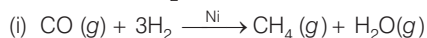

(b) Catalyst does not change  $\Delta H$  of reaction as  $\Delta H$  of reaction is difference between enthalpy of reactants and products. So, it does not change during catalysed reaction.

**Q. 28** Freundlich adsorption isotherm is given by the expression  $\frac{x}{m} = kp^{\frac{1}{n}}$

Which of the following conclusions can be drawn from this expression?

- (a) When  $\frac{1}{n} = 0$ , the adsorption is independent of pressure
- (b) When  $\frac{1}{n} = 0$ , the adsorption is directly proportional to pressure
- (c) When  $n = 0$ ,  $\frac{x}{m}$  vs  $p$  graph is a line parallel to x-axis
- (d) When  $n = 0$ , plot of  $\frac{x}{m}$  vs  $p$  is a curve

**Thinking Process**

To solve this problem follow steps given below.

Write Freundlich equation and transform it into different form depending upon value of  $n$  then choose the correct answer.

**Ans. (a, c)**

According to Freundlich adsorption isotherm

$$\frac{x}{m} \propto p^{\frac{1}{n}} \Rightarrow \frac{x}{m} = kp^{\frac{1}{n}}$$

- (a) At  $\frac{1}{n} = 0$  this equation becomes  $\frac{x}{m} = kp^0 = k$

Extent of adsorption is independent of pressure.

- (c) At  $n = 0$ ,  $\frac{x}{m} = kp^0 = kp^\infty$

Hence,  $\frac{x}{m}$  vs  $p$  graph can be plotted as

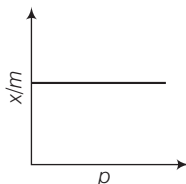

**Q. 29**  $H_2$  gas is adsorbed on activated charcoal to a very little extent in comparison to easily liquefiable gases due to .....

- (a) very strong van der Waals' interaction
- (b) very weak van der Waals' forces
- (c) very low critical temperature
- (d) very high critical temperature

**Ans. (b, c)**

$H_2$  gas is adsorbed on activated charcoal to a very little extent in comparison to easily liquefiable gases due to

- (i) very low van der Waals' forces and
- (ii) very low critical temperature equal to 33 K.

**Q. 30** Which of the following statements are correct?

- (a) Mixing two oppositely charged sols neutralises their charges and stabilises the colloid
- (b) Presence of equal and similar charges on colloidal particles provides stability to the colloids
- (c) Any amount of dispersed liquid can be added to emulsion without destabilising it
- (d) Brownian movement stabilises sols

**Ans. (b, d)**

Presence of equal and similar charges on colloidal particles provides stability to colloids as repulsive forces between charge particles having same charge prevent them from colliding when they come closer to each other.

**Q. 31** An emulsion cannot be broken by ..... and .....

- (a) heating
- (b) adding more amount of dispersion medium
- (c) freezing
- (d) adding emulsifying agent

**Ans. (b, d)**

Emulsions are liquid-liquid colloidal system. They can't be broken by adding more amount of dispersion medium and adding emulsifying agent as on adding more amount of dispersion medium they become dilute and on adding emulsifying agent they get stabilises.

**Q. 32** Which of the following substances will precipitate the negatively charged emulsions?

- (a) KCl
- (b) Glucose
- (c) Urea
- (d) NaCl

**Ans. (a, d)**

The droplets present in emulsion has negative charge. It can be precipitated by adding electrolyte such as KCl, NaCl etc. Since, glucose and urea do not produce ions on dissolving in water.

Hence, they are non-electrolyte and do not precipitate the negatively charged emulsion.

**Q. 33** Which of the following colloids cannot be coagulated easily?

- (a) Lyophobic colloids
- (b) Irreversible colloids
- (c) Reversible colloids
- (d) Lyophilic colloids

**Ans. (c, d)**

Lyophilic colloids (liquid loving colloids) which are also known as reversible colloid can't be coagulated easily. The stability of these colloids are due to

- (i) charge on colloidal particles and
- (ii) solvation of colloidal particles.

**Q. 34** What happens when a Lyophilic sol is added to a Lyophobic sol?

- (a) Lyophobic sol is protected
- (b) Lyophilic sol is protected
- (c) Film of lyophilic sol is formed over lyophobic sol
- (d) Film of lyophobic sol is formed over lyophilic sol

**Ans. (a, c)**

Lyophobic sol is unstable in nature when lyophilic sol is added to lyophobic sol then lyophobic sol is protected because a film of lyophilic sol is formed over lyophobic sol.

Hence, (a) and (c) are correct.

**Q. 35** Which phenomenon occurs when an electric field is applied to a colloidal solution and electrophoresis is prevented?

- (a) Reverse osmosis takes place
- (b) Electroosmosis takes place
- (c) Dispersion medium begins to move
- (d) Dispersion medium becomes stationary

💡 **Thinking Process**

*This problem is based on concept of electroosmosis. It can be solved by knowing the exact meaning of electroosmosis*

**Ans. (b, c)**

The movement of colloidal particles under an applied electric potential is called electrophoresis. When this movement of particles is prevented by some suitable means, it is observed that the dispersion medium begins to move in an electric field. This phenomenon is termed as electroosmosis.

**Q. 36** In a reaction, catalyst changes .....

- (a) physically
- (b) qualitatively
- (c) chemically
- (d) quantitatively

**Ans. (a, b)**

In a reaction catalyst changes physically and qualitatively as it is unaltered during the reaction and remain quantitatively intact after completion of reaction and chemically does not change.

**Q. 37** Which of the following phenomenon occurs when a chalk stick is dipped in ink?

- (a) Adsorption of coloured substance
- (b) Adsorption of solvent
- (c) Absorption and adsorption both of solvent
- (d) Absorption of solvent

**Ans. (a, d)**

When a chalk stick is dipped in ink absorption as well as adsorption both occurs. Adsorption of coloured substance and absorption of solvent takes place.

## Short Answer Type Questions

**Q. 38** Why is it important to have clean surface in surface studies?

**Ans.** It facilitates the adsorption of desired species. If surface is covered by the gases of air then it will not be available for adsorption of desired gases. So, it is very important to have clean surface in surface studies *i.e.*, study of surface chemistry.

**Q. 39** Why is chemisorption referred to as activated adsorption?

**Ans.** Chemisorption referred to as activated adsorption as it involves chemical bond formation between reactant and adsorbent molecules. Formation of chemical bond requires high activation energy. So, it is activated on increasing temperature.

**Q. 40** What type of solutions are formed on dissolving different concentrations of soap in water?

**Ans.** At lower concentration, soap behaves as a normal solution of electrolyte in water. However, after a certain concentration, called critical micelle concentration, colloidal solution is formed due to aggregation of colloidal particles.  
CMC for soap solution is  $10^{-4}$  to  $10^{-3}$  mol L<sup>-1</sup>.

**Q. 41** What happens when gelatin is mixed with gold sol?

**Ans.** Gold sol is a solvent repelling sol *i.e.*, a lyophobic sol and unstable in nature. Addition of gelatin stabilises the gold sol because gelatin forms lyophilic sol and act as a protective colloid.

**Q. 42** How does it become possible to cause artificial rain by spraying silver iodide on the clouds?

**Ans.** As we know artificial rainfall occurs when oppositely charged clouds meet. Since, clouds are colloidal in nature and carry charge. Spray of silver iodide, an electrolyte from aeroplane results in coagulation of colloidal water particles leading to rain. Sometimes electrified sand is also used for this purpose.

**Q. 43** Gelatin which is a peptide is added in ice-creams. What can be its role?

**Ans.** Emulsifying agent is added to emulsion to stabilise the emulsion. Emulsifying agent form a layer between suspended particles and the medium and hence stabilises the emulsion. Ice cream (emulsion) is stabilised by emulsifying agent like gelatin.

**Q. 44** What is collodion?

**Ans.** 4% solution of nitrocellulose in a mixture of alcohol and ether is called collodion.

**Q. 45** Why do we add alum to purify water?

**Ans.** We add alum to purify water as alum coagulates the colloidal impurities present in water, so that these impurities get settle down and remove by decantation or filtration. Thus, water gets purified by adding alum to water.

**Q. 46** What happens when electric field is applied to colloidal solution?

**Ans.** When electric potential is applied to colloidal solution, the colloidal particles move towards one or other electrode. Positively charged particles move towards the cathode while negatively charged particles move towards the anode.

The movement of colloidal particles under an applied electric potential is called electrophoresis. When electrophoresis is prevented by some means, then the dispersion medium begins to move in an electric field. This phenomenon is termed as electroosmosis.

**Q. 47** What causes Brownian motion in colloidal dispersion?

**Ans.** Brownian movement may be defined as continuous *zig-zag* movement of colloidal particles in a colloidal sol. A state of continuous *zig-zag* motion of colloidal particles appears to be in view due to unbalanced bombardment of the particles of dispersed phase by molecules of dispersion medium. This Brownian movement stabilises the sol.



**Q. 48** A colloid is formed by adding  $\text{FeCl}_3$  in excess of hot water. What will happen if excess sodium chloride is added to this colloid?

**Ans.** Positively charged ions coagulate the negatively charged sol and negatively charged ion coagulate the positively charged sol. Positively charged sol of hydrated ferric oxide is formed when  $\text{FeCl}_3$  is added in excess of hot water. On adding excess of  $\text{NaCl}$  to this sol, negatively charged  $\text{Cl}^-$  ions coagulate the positively charged sol of hydrated ferric oxide.

**Q. 49** How do emulsifying agents stabilise the emulsion?

**Ans.** Emulsifying agents stabilise the emulsion by forming an interfacial layer between suspended particles and the dispersion medium. e.g., gelatin is added to ice cream to stabilise it.

**Q. 50** Why are some medicines more effective in the colloidal form?

**Ans.** Some medicines are more effective in colloidal form because they have large surface area so easily assimilated in the body.

**Q. 51** Why does leather get hardened after tanning?

**Ans.** Animal hide is colloidal in nature and has positively charged particles. When it is soaked in tannin (negatively charged), a colloid, it results in mutual coagulation and gets hardened. Thus, leather gets hardened after tanning.

**Q. 52** How does the precipitation of colloidal smoke take place in Cottrell precipitator?

**Ans.** In Cottrell precipitator, smoke particles (charged) are passed through a chamber containing plates with charge opposite to the smoke particles, smoke particles lose their charge on the plates and get precipitated.

**Q. 53** How will you distinguish between dispersed phase and dispersion medium in an emulsion?

**Ans.** To distinguish between dispersed phase and dispersion medium we increase the concentration of any one dispersion medium or dispersed phase then notice the change.

When dispersion medium is added to an emulsion, it gets diluted to any extent. But on adding dispersed phase it forms a separate layer, if added in excess.



**Q. 54** On the basis of Hardy-schulze rule explain why the coagulating power of phosphate is higher than chloride?

**Ans.** Minimum quantity of an electrolyte required to cause precipitation of a sol is called its coagulating value. Greater the charge on flocculating ion and smaller is the amount of electrolyte required for precipitation, higher is the coagulating power of coagulating ion (Hardy-Schulze Law).

Phosphate ion bear  $-3$  charge while chloride ion carries only  $-1$  charge and due to high charge phosphate ion has high coagulating power than that of chloride ion.

**Q. 55** Why does bleeding stop by rubbing moist alum?

**Ans.** Blood is a colloidal sol. When we rub the injured part with moist alum then coagulation of blood takes place. Hence, main reason is coagulation, which stops the bleeding.

**Q. 56** Why is  $\text{Fe(OH)}_3$  colloid positively charged, when prepared by adding  $\text{Fe(OH)}_3$  to hot water?

**Ans.** Charge on sol is decided by adsorption of ions present in medium. Adsorption of positively charged  $\text{Fe}^{3+}$  ions takes place by the sol of hydrated ferric oxide. Thus,  $\text{Fe(OH)}_3$  colloid has positive charge when prepared by adding  $\text{Fe(OH)}_3$  to hot water.

**Q. 57** Why do physisorption and chemisorption behave differently with rise in temperature?

**Ans.** Behaviour of physisorption and chemisorption on increase in temperature can be explained on the basis of nature of forces present to bind their particles. Physisorption involves weak van der Waals' forces which weakens with increase in temperature.

Chemisorption involves formation of chemical bond which requires activation energy hence, it is favoured by rise in temperature.

**Q. 58** What happens when dialysis is prolonged?

**Ans.** Traces of electrolyte which stabilises the colloids is removed completely making the colloid unstable. So, coagulation occurs on prolonged dialysis.

**Q. 59** Why does the white precipitate of silver halide become coloured in the presence of dye eosin?

**Ans.** White coloured precipitate of silver halide becomes coloured in the presence of dye eosin because dye eosin (coloured) gets adsorbed on the surface of silver halide precipitate.

**Q. 60** What is the role of activated charcoal in gas mask used in coal mines?

**Ans.** Role of activated charcoal in gas mask can be explained on the basis of adsorption. Activated charcoal adsorbs various poisonous gases on its surface present in coal mines.

**Q. 61** How does a delta form at the meeting place of sea and river water?

**Ans.** Formation of delta at the meeting place of sea and river water is due to coagulation. River water (colloid of sea water + clay) has many dissolved electrolytes. The place where river meets sea is the site for coagulation. Deposition of coagulated clay results in delta formation.

**Q. 62** Give an example where physisorption changes to chemisorption with rise in temperature. Explain the reason for change.

**Ans.** Adsorption of  $H_2$  on finely divided nickel (physisorption) involves weak van der Waals' forces. When temperature is increased, hydrogen molecules dissociate into hydrogen atoms, form chemical bonds with the metal atoms at the surface (chemisorption).

**Q. 63** Why is desorption important for a substance to act as good catalyst?

**Ans.** Desorption is important for a substance to act as a good catalyst so that after the reaction, the products formed on the surface separate out (desorbed) to create free surface again for other reactant molecules to approach the surface and react.

If desorption does not occur then other reactants are left with no space on the catalysts surface for adsorption and reaction will stop.

**Q. 64** What is the role of diffusion in heterogeneous catalyst?

**Ans.** Diffusion of gas molecules occur at the surface of catalyst (solid) followed by adsorption. In the same way, the product formed diffuse from the surface of the catalyst leaving the surface free for more reactant molecules to get adsorbed and undergo reaction.

**Q. 65** How does a solid catalyst enhance the rate of combination of gaseous molecules?

**Ans.** When gaseous molecules come in contact with the surface of a solid catalyst, a weak chemical bond is formed between the surface (catalyst) molecules and reactant (gas) molecules. Thus, concentration of reactant molecules increases at the surface.

The rate of reaction increases by adsorption of different molecules side by side facilitating the chemical reaction. Adsorption, being exothermic also help in increasing the rate of reaction (chemisorption increases with rise in temperature).

**Q. 66** Do the vital functions of the body such as digestion get affected during fever? Explain your answer.

**Ans.** The optimum temperature range for enzymatic activity is 298-310 K, *i.e.*, enzymes are inactive beyond this temperature range (high or low).

Thus, during fever (temperature  $>310$  K) the activity of enzymes may be affected.

## Matching The Columns

**Q. 67** Method of formation of solution is given in Column I. Match it with the type of solution given in Column II.

Column I	Column II
A. Sulphur vapours passed through cold water.	1. Normal electrolyte solution
B. Soap mixed with water above critical micelle concentration.	2. Molecular colloids
C. White of egg whipped with water.	3. Associated colloid
D. Soap mixed with water below critical micelle concentration.	4. Macromolecular colloids

**Ans. A.** → (2)    **B.** → (3)    **C.** → (4)    **D.** → (1)

- A. When sulphur vapours passed through cold water it leads to formation of molecular colloids.
- B. When soap is mixed with water above critical micelle concentration it lead to formation of associated colloids.
- C. White of egg whipped with water is an example of macromolecular colloids in which high molecular mass proteneous molecule acts as a colloidal particle.
- D. Soap mixed with water below critical micelle concentration is known as normal electrolyte solution.

**Q. 68** Match the statement given in Column I with the phenomenon given in Column II.

Column I	Column II
A. Dispersion medium moves in an electric field.	1. Osmosis
B. Solvent molecules pass through semipermeable membrane towards solvent side.	2. Electrophoresis
C. Movement of charged colloidal particles under the influence of applied electric potential towards oppositely charged electrodes.	3. Electroosmosis
D. Solvent molecules pass through semipermeable membranes towards solution side.	4. Reverse-osmosis

**Ans. A.** → (3)    **B.** → (4)    **C.** → (2)    **D.** → (1)

- A. Dispersion medium moves in an electric field is known as electroosmosis.
- B. Solvent molecules pass through semipermeable membrane towards solvent side is known as reverse-osmosis.
- C. Movement of charged colloidal particles under the influence of applied electric potential towards oppositely charge electrodes is known as electrophoresis.
- D. Solvent molecules pass through semipermeable membranes towards solution side is known as osmosis.

**Q. 69** Match the items given in Column I and Column II.

Column I	Column II
A. Protective colloid	1. $\text{FeCl}_3 + \text{NaOH}$
B. Liquid-liquid colloid	2. Lyophilic colloids
C. Positively charged colloid	3. Emulsion
D. Negatively charged colloid	4. $\text{FeCl}_3 + \text{hot water}$

**Ans. A.** → (2)    **B.** → (3)    **C.** → (4)    **D.** → (1)

- A. Lyophobic colloid (solvent hating colloid) are readily protected by small amount of electrolyte. These colloids are also stabilised by addition of lyophilic colloids which makes a protective layer around lyophobic sol. Hence, lyophilic sol are known as protective colloid.
- B. Liquid-liquid colloid is also known as emulsion if they are partially miscible or immiscible liquids.
- C. When  $\text{FeCl}_3$  is added to hot water it lead to the formation of positively charged colloid.
- D. When  $\text{NaOH}$  is added to  $\text{FeCl}_3$  it lead to the formation of negatively charged colloid.

**Q. 70** Match the types of colloidal systems given in Column I with the name given in Column II.

Column I	Column II
A. Solid in liquid	1. Foam
B. Liquid in solid	2. Sol
C. Liquid in liquid	3. Gel
D. Gas in liquid	4. Emulsion

**Ans.** A. → (2) B. → (3) C. → (4) D. → (1)

Colloids are classified on the basis of types of dispersed phase and dispersion medium.

Dispersed phase	Dispersion medium	Name
A. Solid in	Liquid	Sol
B. Liquid in	Solid	Gel
C. Liquid in	Liquid	Emulsion
D. Gas in	Liquid	Foam

**Q. 71** Match the items of Column I and Column II.

Column I	Column II
A. Dialysis	1. Cleansing action of soap
B. Peptisation	2. Coagulation
C. Emulsification	3. Colloidal sol formation
D. Electrophoresis	4. Purification

**Ans.** A. → (4) B. → (3) C. → (1) D. → (2)

A. Purification of colloid can be done by dialysis in which ions/particles are removed from solution through semipermeable membrane.

B. Peptisation is a process in which when small quantity of electrolyte (peptising agent) is added to precipitate. It leads to formation of colloidal solution.

C. The process of removing of oily or greasy dirt from the cloth is done by emulsification.

D. Process of setting of colloidal particle is called coagulation.

Electrophoresis is a process in which on applying electric potential to the electrodes dipped in sol, the oppositely charged particles of colloidal solution move towards oppositely charged electrodes, get discharged and precipitated.

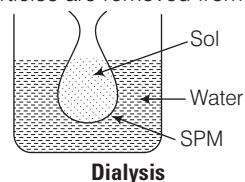

**Q. 72** Match the items of Column I and Column II.

Column I	Column II
A. Butter	1. Dispersion of liquid in liquid
B. Pumice stone	2. Dispersion of solid in liquid
C. Milk	3. Dispersion of gas in solid
D. Paints	4. Dispersion of liquid in solid

**Ans.** A. → (4) B. → (3) C. → (1) D. → (2)

A. Butter is an example of dispersion of liquid in solid.

B. Pumice stone is an example of dispersion of gas in solid in which gas bubbles are peared within solid particles.

C. Milk is a dispersion of liquid in liquid in which fats and protein are dissolved in milk.

D. Paint is an example of solid in liquid.

## Assertion and Reason

*In the following questions a statement of assertion (A) followed by a statement of reason (R) is given. Choose the correct answer out of the following choices.*

- (a) Assertion and reason both are correct and the reason is correct explanation of assertion.
- (b) Assertion and reason both are correct but reason does not explain assertion.
- (c) Assertion is correct, but reason is incorrect.
- (d) Both assertion and reason are incorrect.
- (e) Assertion is incorrect, but reason is correct.

**Q. 73** Assertion (A) An ordinary filter paper impregnated with collodion solution stops the flow of colloidal particles.

Reason (R) Pore size of the filter paper becomes more than the size of colloidal particle.

**Ans. (c)** Assertion is correct, but reason is wrong.

An ordinary filter paper impregnated with collodion solution stops the flow of colloidal particles because pore size of the filter paper becomes smaller than the size of colloidal particles.

**Q. 74** Assertion (A) Colloidal solution show colligative properties.

Reason (R) Colloidal particles are large in size.

**Ans. (b)** Assertion and reason both are correct, but reason does not explain assertion.

Colloidal solutions show colligative properties as colloidal particles have large size so colloidal particles have small value of colligative properties because number of particles are small in comparison to normal solution.

**Q. 75** Assertion (A) Colloidal solutions do not show Brownian motion.

Reason (R) Brownian motion is responsible for stability of sols.

**Ans. (e)** Assertion is incorrect, but reason is correct.

Colloidal solutions show Brownian motion and this Brownian motion is responsible for stability of sols.

**Q. 76** Assertion (A) Coagulation power of  $\text{Al}^{3+}$  is more than  $\text{Na}^+$ .

Reason (R) Greater the valency of the flocculating ion added, greater is its power to cause precipitation (Hardy–Schulze rule) .

**Ans. (a)** Assertion and reason both are correct and reason is correct explanation of assertion.

According to Hardy–Schulze law greater the charge/valency on flocculating ion added greater will be its power to cause precipitation.

Coagulating power  $\propto$  Valency of flocculating ion

**Q. 77** Assertion (A) Detergents with low CMC are more economical to use.

Reason (R) Cleansing action of detergents involves the formation of micelles. These are formed when the concentration of detergents becomes equal to CMC.

**Ans. (a)** Assertion and reason both are correct and reason is correct explanation of assertion.

Detergents with low CMC are more economic to use as cleansing action of detergents involves the formation of micelles. These are formed when the concentration of detergent becomes equal to CMC. If CMC has lower value then it will form CMC easily and readily.

## Long Answer Type Questions

**Q. 78** What is the role of adsorption in heterogeneous catalysis?

**Ans.** Catalyst is used to increase rate of reaction. Heterogeneous catalyst is used to increase rate of reaction in which catalyst is not in phase with reactants and products.

*Role of adsorption in heterogeneous catalysis are*

- (i) Diffusion of reactants to the surface of the catalyst.
- (ii) Reactants are adsorbed on the catalyst surface.
- (iii) Occurrence of chemical reaction at catalyst surface.
- (iv) Desorption.
- (v) Diffusion of reaction products away from the catalysts surface.

e.g.,

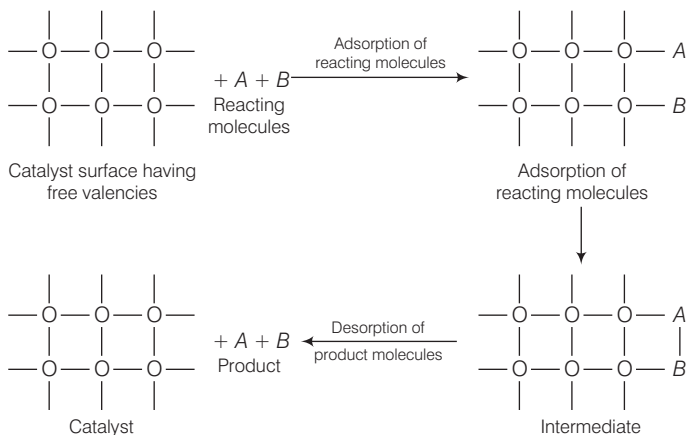

**Role of adsorption in heterogeneous catalysis**

**Q. 79** What are the applications of adsorption in chemical analysis?

**Ans.** There are various applications of adsorption in chemical analysis.

*Some of which are as follows*

- (i) **In thin layer chromatography** The lower adsorbing particles comes out readily while another having higher adsorbing tendency comes out later. On this basis compounds are separated or analysed.
- (ii) **In adsorption indicators** Surface of certain precipitate has an ability to adsorb some dyes to produce a characteristic colour e.g., AgX adsorbs eosin dye and thereby producing a characteristic colour at the end point.
- (iii) **In qualitative analysis** Specific material has specific adsorption tendency so particular ion can be identified very easily.
- (iv) **In the separation of inert gases** Different inert gases are adsorbed to different extents at different temperatures on coconut charcoal. This forms the basis of their separation from a mixture.

**Q. 80** What is the role of adsorption in froth floatation process used especially for concentration of sulphide ores?

**Ans.** In froth floatation process sulphide ore is shaken with pine oil and water, the ore particles are adsorbed on froth that floats and the gangue particles settle down in tank. Thus, role of adsorption in froth floatation process can be understood as following processes.

- (i) Adsorption of pine oil on sulphide ore particles.
- (ii) Formation of emulsion takes place.
- (iii) Froth is formed along with ore particles.
- (iv) Mechanism of the functioning of shape selective catalysis.  
As sulphide are extracted using froth floatation method therefore, only sulphide ore particles will show these type of adsorbing tendency.

**Q. 81** What do you understand by shape selective catalysis? Why are zeolites good shape selective catalysts?

**Ans.** The catalytic reaction which depends upon pore structure of catalyst and the size of the reactant and product molecules is known as shape selective catalysts. Zeolites are good shape selective catalyst because of honey comb like structure.

- (i) They are microporous aluminosilicates with Al—O—Si framework and general formula  $M_{x/n} [(AlO_2)_x (SiO_2)_y] mH_2O$
- (ii) The reactions taking place in zeolites depend upon the size and shape of the reactant and product molecules as well as upon the pores and cavities of the zeolites.
- (iii) Zeolites are widely used as catalysts in petrochemical industries for cracking of hydrocarbons and isomerisation. They are also used for removing permanent hardness of water.
- (iv) e.g., ZSM-5 is a catalyst used in petroleum industry



# 6

## General Principle and Processes of Isolation of Elements

### Multiple Choice Questions (MCQs)

**Q. 1** In the extraction of chlorine by electrolysis of brine .....

- (a) oxidation of  $\text{Cl}^-$  ion to chlorine gas occurs
- (b) reduction of  $\text{Cl}^-$  ion to chlorine gas occurs
- (c) for overall reaction  $\Delta G^\circ$  has negative value
- (d) a displacement reaction takes place

**Ans. (a)** Following reaction takes place in the extraction of chlorine by electrolysis

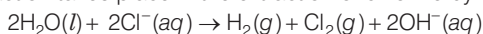

From the above reaction it is very clear that the oxidation of  $\text{Cl}^-$  ion to chlorine gas occurs. Thus, option (a) is the correct answer.

$\Delta^\circ G$  for this reaction is +422kJ. Therefore, thermodynamically reaction is not feasible. We know that

$$\Delta^\circ G = -nFE^\circ$$

By using this equation value of  $E^\circ$  can be calculated. Thus,

$$E^\circ = -\frac{\Delta G^\circ}{nF} = -2.2V$$

Therefore, for the occurrence of this reaction, external potential (emf) greater than 2.2V is required. Due to this fact (c) is not the correct option.



**Q. 2** When copper ore is mixed with silica, in a reverberatory furnace copper matte is produced. The copper matte contains

- (a) sulphides of copper (II) and iron (II)
- (b) sulphides of copper (II) and iron (III)
- (c) sulphides of copper (I) and iron (II)
- (d) sulphides of copper (I) and iron (III)

**Ans. (c)** When copper ore is mixed with silica in a reverberatory furnace copper matte is produced. The copper matte contains sulphide of copper (I) and iron (II).

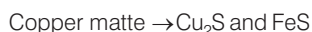

**Q.3** Which of the following reactions is an example of autoreduction?

- (a)  $\text{Fe}_3\text{O}_4 + 4\text{CO} \longrightarrow 3\text{Fe} + 4\text{CO}_2$
- (b)  $\text{Cu}_2\text{O} + \text{C} \longrightarrow 2\text{Cu} + \text{CO}$
- (c)  $\text{Cu}^{2+}(\text{aq}) + \text{Fe}(\text{s}) \longrightarrow \text{Cu}(\text{s}) + \text{Fe}^{2+}(\text{aq})$
- (d)  $\text{Cu}_2\text{O} + \frac{1}{2}\text{Cu}_2\text{S} \longrightarrow 3\text{Cu} + \frac{1}{2}\text{SO}_2$

**Ans. (d)**  $\text{Cu}_2\text{O} + \frac{1}{2}\text{Cu}_2\text{S} \longrightarrow 3\text{Cu} + \frac{1}{2}\text{SO}_2$

This reaction includes reduction of copper (I) oxide by copper (I) sulphide. In this process, copper is reduced by itself hence this process is known as autoreduction and the solidified copper, so, obtained is known as blister copper.

**Q. 4** A number of elements are available in earth's crust but most abundant elements are .....

- (a) Al and Fe
- (b) Al and Cu
- (c) Fe and Cu
- (d) Cu and Ag

**Ans. (a)** Among a number of elements which are available in earth crust, the most abundant elements are aluminium and iron. Aluminium is third most abundant element in earth crust. *i.e.*, 8.3% by weight while iron present in earth crust with 4.2% by weight. Copper and silver are also found in earth crust but their abundance percentage is low.

**Q. 5** Zone refining is based on the principle that .....

- (a) impurities of low boiling metals can be separated by distillation.
- (b) impurities are more soluble in molten metal than in solid metal.
- (c) different components of a mixture are differently adsorbed on an adsorbent.
- (d) vapours of volatile compound can be decomposed in pure metal.

**Ans. (b)** Zone refining is based on the principle that the impurities are more soluble in molten state than in solid state of the metal. A circular mobile heater fixed at one end of impure metal rod. The molten zone moves along with heater which is moved forward.

As the heater moves forward, the pure metal crystallises out of the melt and the impurities pass on into adjacent molten zone. The process is repeated several times and the heater is moved in the same direction.

At one end, impurities get concentrated. This end is cut off. *e.g.*, germanium, silicon, gallium etc., are refined by this method.

**Q. 6** In the extraction of copper from its sulphide ore, the metal is formed by the reduction of  $\text{Cu}_2\text{O}$  with

- (a) FeS (b) CO  
(c)  $\text{Cu}_2\text{S}$  (d)  $\text{SO}_2$

**Ans.(c)** In the extraction of copper from its sulphide ore, the metal is formed by the reduction of  $\text{Cu}_2\text{O}$  with  $\text{Cu}_2\text{S}$ . This reaction completes with the process of autoreduction.

Chemical reaction occurring in this reaction is as follows

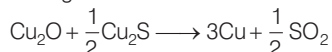

In this process, copper appears as blister copper.

**Q. 7** Brine is electrolysed by using inert electrodes. The reaction at anode is .....

- (a)  $\text{Cl}^- (\text{aq}) \rightarrow \frac{1}{2}\text{Cl}_2 (\text{g}) + \text{e}^-$ ;  $E_{\text{Cell}}^{\text{s}} = 1.36 \text{ V}$   
 (b)  $2\text{H}_2\text{O} (\text{l}) \rightarrow \text{O}_2 (\text{g}) + 4\text{H}^+ + 4\text{e}^-$ ;  $E_{\text{Cell}}^{\text{s}} = 1.23 \text{ V}$   
 (c)  $\text{Na}^+ (\text{aq}) + \text{e}^- \rightarrow \text{Na} (\text{s})$ ;  $E_{\text{Cell}}^{\text{s}} = 2.71 \text{ V}$   
 (d)  $\text{H}^+ (\text{aq}) + \text{e}^- \rightarrow \frac{1}{2}\text{H}_2 (\text{g})$ ;  $E_{\text{Cell}}^{\text{s}} = 0.00 \text{ V}$

**Ans. (a)** Brine is electrolysed by using inert electrodes. The possible reactions occurring at anode are

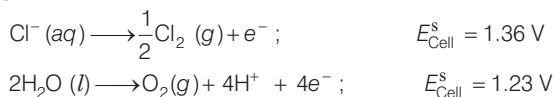

The reaction at anode with lower value of  $E^\ominus$  is preferred and therefore water should get oxidised in preference to  $\text{Cl}^- (\text{aq})$ . However,  $\text{Cl}_2$  is produced instead of  $\text{O}_2$ . This unexpected result is explained on the basis of the fact that water needs greater voltage for oxidation to  $\text{O}_2$  (as it is kinetically slow process) than that needed for oxidation of  $\text{Cl}^-$  ions to  $\text{Cl}_2$ .

**Q. 8** In the metallurgy of aluminium .....

- (a)  $\text{Al}^{3+}$  is oxidised to Al (s).  
 (b) graphite anode is oxidised to carbon monoxide and carbon dioxide.  
 (c) oxidation state of oxygen changes in the reaction at anode.  
 (d) oxidation state of oxygen changes in the overall reaction involved in the process.

**Ans. (b)** In the metallurgy of aluminium, electrolysis is performed in a steel vessel with lining of carbon acts as cathode and graphite acts as anode. During this process graphite anode is oxidised to CO and  $\text{CO}_2$ .

Chemical reaction occurring in this process is as follows

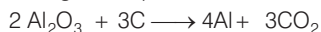

This process is known as Hall - Heroult process. The electrolytic reactions are

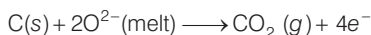
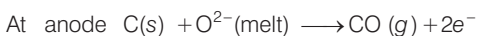

**Q. 9** Electrolytic refining is used to purify which of the following metals?

- (a) Cu and Zn      (b) Ge and Si      (c) Zr and Ti      (d) Zn and Hg

**Ans. (a)** Copper and zinc are two metals which are generally purified by using electrolyte refining. In this process, impure metal is used as anode and pure metal is used as a cathode. Impurities from the blister copper or impure zinc deposit as anode mud.

**Q. 10** Extraction of gold and silver involves leaching the metal with  $\text{CN}^-$  ion. The metal is recovered by .....

- (a) displacement of metal by some other metal from the complex ion.  
 (b) roasting of metal complex.  
 (c) calcination followed by roasting.  
 (d) thermal decomposition of metal complex.

**Ans. (a)** Extraction of gold and silver involves leaching the metal with  $\text{CN}^-$  ion. The metal is recovered by displacement of metal by some other metal from the complex ion. This is an oxidation reaction.

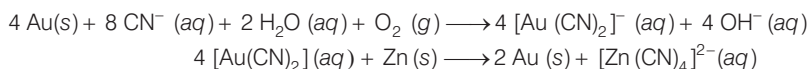

Here, Zn acts as a reducing agent.

**Direction** (Q. Nos. 11-13) Answer the questions on the basis of figure

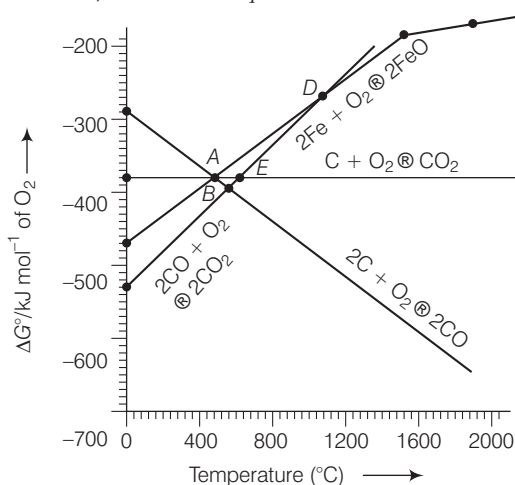

**Q. 11** Choose the correct option of temperature at which carbon reduces  $\text{FeO}$  to iron and produces  $\text{CO}$ .

- (a) Below temperature at point A  
 (b) Approximately at the temperature corresponding to point A  
 (c) Above temperature at point A but below temperature at point D  
 (d) Above temperature at point A

**Thinking Process**

This problem is based on concept of Ellingham diagram which relates Gibbs free energy of reaction and temperature. The point above which greater the negative value of formation of compound is observed, compound will form at that temperature. At a particular temperature compound having higher negative value of Gibbs free energy will be formed first.

**Ans. (d)** In the figure shown above point A

$$\Delta_f G^\circ_{(C,CO)} < \Delta_f G^\circ_{(Fe, FeO)}$$

Therefore, above point A, C reduces FeO to Fe forming carbon monoxide. Hence, reduction of FeO by carbon occurs above point A only.

**Q. 12** Below point 'A' FeO can .....

- (a) be reduced by carbon monoxide only.
- (b) be reduced by both carbon monoxide and carbon.
- (c) be reduced by carbon only.
- (d) not be reduced by both carbon and carbon monoxide.

**Ans. (a)** Below point A Gibbs free energy change for the formation of CO<sub>2</sub> from CO ( $\Delta G^\circ_{CO,CO_2}$ ) has lower value (more negative value) than Gibbs free energy change for the formation of FeO ( $\Delta G^\circ_{Fe,FeO}$ ). Hence, FeO will be reduced by CO only below point A.

**Q. 13** For the reduction of FeO at the temperature corresponding to point D, which of the following statements is correct?

- (a)  $\Delta G$  value for the overall reduction reaction with carbon monoxide is zero.
- (b)  $\Delta G$  value for the overall reduction reaction with a mixture of 1 mol carbon and 1 mol oxygen is positive.
- (c)  $\Delta G$  value for the overall reduction reaction with a mixture of 2 mol carbon and 1 mol oxygen will be positive.
- (d)  $\Delta G$  value for the overall reduction reaction with carbon monoxide is negative.

**Ans. (a)** At point D,  $\Delta G$  curve for formation of CO<sub>2</sub> from CO and FeO from Fe intersect each other therefore, overall reduction of FeO with CO is zero.  
Hence, (a) is the correct choice.

## Multiple Choice Questions (More Than One Options)

**Q. 14** At the temperature corresponding to which of the points in Fig. FeO will be reduced to Fe by coupling the reaction  $2FeO \longrightarrow 2Fe + O_2$  with all of the following reactions?

1.  $C + O \longrightarrow CO_2$
2.  $2C + O_2 \longrightarrow 2CO$
3.  $2CO + O_2 \longrightarrow 2CO_2$

- (a) Point A      (b) Point B      (c) Point D      (d) Point E

**Ans. (b, d)**

Below point B and E, FeO will be reduced to Fe by all the three reactions shown above in the question.  $\Delta G^\circ_{(C, CO_2)}$ ,  $\Delta G^\circ_{(C, CO)}$ ,  $\Delta G^\circ_{(CO, CO_2)}$  lie below  $\Delta_f G^\circ_{(Fe, FeO)}$  curve at point B and E. Therefore, FeO will be reduced by all three reactions.

Hence, options (b) and (d) are correct choice.

**Q. 15** Which of the following options are correct?

- (a) Cast iron is obtained by remelting pig iron with scrap iron and coke using hot air blast.
- (b) In extraction of silver, silver is extracted as cationic complex.
- (c) Nickel is purified by zone refining.
- (d) Zr and Ti are purified by van Arkel method.

**Thinking Process**

*This process is based on concept of purification techniques and formation of cast iron.*

**Ans. (a, d)**

Correct statements are

- (a) Cast iron is obtained by remelting pig iron with scarp iron and coke using hot air blast.
- (d) Zr and Ti are purified by van Arkel method as

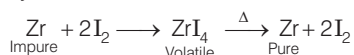

(b) and (c) can be correctly stated as

- (b) In extraction of silver, silver is extracted as anionic complex  $[\text{Ag}(\text{CN})_2]^-$
- (c) Nickel is purified by vapour phase refining method.

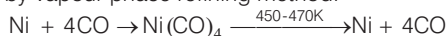

**Q. 16** In the extraction of aluminium by Hall-Heroult process, purified  $\text{Al}_2\text{O}_3$  is mixed with  $\text{CaF}_2$  to

- (a) lower the melting point of  $\text{Al}_2\text{O}_3$
- (b) increase the conductivity of molten mixture.
- (c) reduce  $\text{Al}^{3+}$  into  $\text{Al}(s)$
- (d) acts as catalyst

**Thinking Process**

*This problem is based on extraction of aluminium using Hall-Heroult process.*

**Ans. (a, b)**

In the metallurgy of aluminium  $\text{Al}_2\text{O}_3$  is mixed with  $\text{Na}_3\text{AlF}_6$  and  $\text{CaF}_2$  which causes following affects.

- (i) Lower the melting point of  $\text{Al}_2\text{O}_3$
- (ii) Increase the conductivity of molten mixture

**Q. 17** Which of the following statements is correct about the role of substances added in the froth floatation process?

- (a) Collectors enhance the non-wettability of the mineral particles.
- (b) Collectors enhance the wettability of gangue particles.
- (c) By using depressants in the process two sulphide ores can be separated.
- (d) Froth stabilisers decrease wettability of gangue.

**Thinking Process**

*This problem is based on the method involved in froth floatation method and function of collector and depressants.*

**Ans. (a, c)**

Froth floatation process is used to extract metal from sulphide ore. This method utilises collectors and depressants whose functions are as follows

- (i) Collectors enhance the non-wettability of the mineral particles.
- (ii) By using depressants in the process two sulphide ores can be separated. e.g., sodium cyanide is used as a depressant to separate lead sulphide ore from zinc sulphide ore.

**Q. 18** In the froth floatation process, zinc sulphide and lead sulphide can be separated by .....

- (a) using collectors (b) adjusting the proportion of oil to water  
(c) using depressant stabilisers (d) using froth

**Ans. (b, c)**

Froth floatation method is used to extract metal from sulphide ore. ZnS and PbS can be separated by using depressant and adjusting the proportion of oil to water. Depressant used for this purpose is NaCN. It selectively prevents ZnS from coming to the froth. Hence, (b) and (c) are correct choices.

**Q. 19** Common impurities present in bauxite are .....

- (a) CuO (b) ZnO (c) Fe<sub>2</sub>O<sub>3</sub> (d) SiO<sub>2</sub>

**Ans. (c, d)**

Bauxite is an ore of aluminium which contain Fe<sub>2</sub>O<sub>3</sub> and SiO<sub>2</sub> as common impurities.

**Q. 20** Which of the following ores are concentrated by froth floatation?

- (a) Haematite (b) Galena (c) Copper pyrites (d) Magnetite

**Ans. (b, c)**

Haematite (Fe<sub>2</sub>O<sub>3</sub>) and magnetite (Fe<sub>3</sub>O<sub>4</sub>) are oxide ores while galena (PbS) and copper pyrites (CuFeS<sub>2</sub>) are sulphide ores. As we know sulphide ores are extracted by using froth floatation method. Hence, (b) and (c) are the correct choices.

**Q. 21** Which of the following reactions occur during calcination?

- (a)  $\text{CaCO}_3 \longrightarrow \text{CaO} + \text{CO}_2$   
(b)  $2\text{FeS}_2 + \frac{11}{2} \text{O}_2 \longrightarrow \text{Fe}_2\text{O}_3 + 4\text{SO}_2$   
(c)  $\text{Al}_2\text{O}_3 \cdot x\text{H}_2\text{O} \longrightarrow \text{Al}_2\text{O}_3 + x\text{H}_2\text{O}$   
(d)  $\text{ZnS} + \frac{3}{2} \text{O}_2 \longrightarrow \text{ZnO} + \text{SO}_2$

#### 🔍 Thinking Process

*This process is based on concept of calcination.*

**Ans. (a, c)**

Calcination involves heating of the ore below its melting point in the absence of air or in limited supply of air. Oxygen containing ores like oxide, hydroxides and carbonates are calcined. Thus, the following reactions occur during calcination.

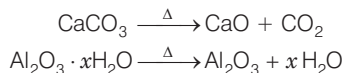

**Q. 22** For the metallurgical process of which of the ores calcined ore can be reduced by carbon?

- (a) Haematite (b) Calamine (c) Iron pyrites (d) Sphalerite

**Ans. (a, b)**

In the metallurgical process, the oxide ores are reduced by carbon. Sulphide ore cannot be reduced by carbon. Here, haematite (Fe<sub>2</sub>O<sub>3</sub>) and calamine (ZnO) are oxide ores of iron and zinc respectively while iron pyrites (FeS<sub>2</sub>) and sphalerite (ZnS) are sulphide ores of iron and zinc respectively.

Therefore, haematite and calamine can be reduced by carbon.

**Q.23** The main reactions occurring in blast furnace during extraction of iron from haematite ore .....

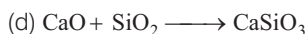
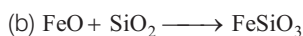
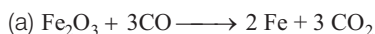

**Ans. (a, d)**

In extraction of iron from haematite ore following reactions take place.

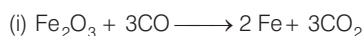

This reaction represents reduction of  $\text{Fe}_2\text{O}_3$  to Fe.

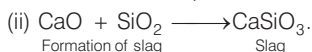

Formation of slag

Slag

**Q. 24** In which of the following method of purification, metal is converted to its volatile compound which is decomposed to give pure metal?

(a) Heating with stream of carbon monoxide

(b) Heating with iodine

(c) Liquation

(d) Distillation

💡 **Thinking Process**

*This problem is based on purification of metal using vapour phase refining method.*

**Ans. (a, b)**

Vapour phase refining method includes

(i) Heating of metal with stream of CO



(ii) Heating with iodine

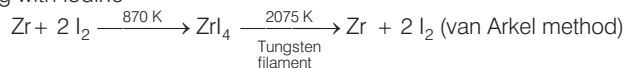

**Q. 25** Which of the following statements are correct?

(a) A depressant prevents certain type of particle to come to the froth.

(b) Copper matte contains  $\text{Cu}_2\text{S}$  and  $\text{ZnS}$ .

(c) The solidified copper obtained from reverberatory furnace has blistered appearance due to evolution of  $\text{SO}_2$  during the extraction.

(d) Zinc can be extracted by self-reduction.

**Ans. (a, c)**

*Correct statements are*

(i) A depressant prevents certain type of particle to come to the froth. e.g., NaCN is added as a depressant during separation of  $\text{PbS}$  and  $\text{ZnS}$ .

(ii) The solidified copper obtained from reverberatory furnace has blistered appearance due to evolution of  $\text{SO}_2$  during the extraction.

(b) and (d) are incorrect statements, and can be correctly stated as

(iii) Copper matte contains  $\text{Cu}_2\text{S}$  and  $\text{FeS}$ .

(iv) Zinc can be extracted by reduction of  $\text{ZnO}$  with carbon.

**Q. 26** In the extraction of chlorine from brine .....

- (a)  $\Delta G^{\circ}$  for the overall reaction is negative.  
 (b)  $\Delta G^{\circ}$  for the overall reaction is positive.  
 (c)  $E^{\circ}$  for the overall reaction has negative value.  
 (d)  $E^{\circ}$  for the overall reaction has positive value.

**Ans. (b, c)**

Electrolysis of brine solution is used to extract chlorine. Overall chemical reaction occurring in this process and value of  $\Delta G^{\circ}$  can be shown as

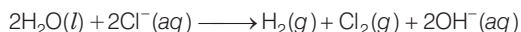

For the given reaction, value of  $\Delta G^{\circ}$  is 422 kJ

Using  $\Delta G^{\circ} = -nFE^{\circ}$ , the value of  $E^{\circ} = E^{\circ} - 2.2\text{V}$ .

Therefore,  $\Delta G^{\circ}$  for the overall reaction is positive and  $E^{\circ}$  has negative value.

## Short Answer Type Questions

**Q. 27** Why is an external emf of more than 2.2V required for the extraction of  $\text{Cl}_2$  from brine?

**Ans.**  $2\text{Cl}^-(aq) + 2\text{H}_2\text{O}(l) \longrightarrow 2\text{OH}^-(aq) + \text{H}_2(g) + \text{Cl}_2(g)$

For the given reaction, value of  $\Delta G^{\circ}$  is + 422 kJ.

Using  $\Delta G^{\circ} = -nFE^{\circ}$ , the value of  $E^{\circ} = -2.2\text{V}$ .

Therefore, an external emf greater than 2.2 V is required for the extraction of  $\text{Cl}_2$  from brine.

**Q. 28** At temperature above 1073 K, coke can be used to reduce FeO to Fe. How can you justify this reduction with Ellingham diagram?

**Ans.** Using Ellingham diagram, we observe that at temperature greater than 1073 K;  $\Delta G_{(\text{C}, \text{CO})} < \Delta G_{(\text{Fe}, \text{FeO})}$ . We know that according to Ellingham diagram, compound having lower  $\Delta_r G^{\circ}$  undergo its formation.

Hence, coke can reduce FeO to Fe.

**Q. 29** Wrought iron is the purest form of iron. Write a reaction used for the preparation of wrought iron from cast iron. How can the impurities of sulphur, silicon and phosphorus be removed from cast iron?

**Ans. (a)** 
$$\underset{\substack{\text{Haematite} \\ \text{lining}}}{\text{Fe}_2\text{O}_3} + \underset{\substack{\text{Impurities} \\ \text{(present in cast iron)}}}{3\text{C}} \longrightarrow \underset{\substack{\text{Wrought} \\ \text{iron}}}{2\text{Fe}} + 3\text{CO}$$

This reaction takes place in reverberatory furnace lined with haematite.

(b) The haematite oxidises S to  $\text{SO}_2$ , Si to  $\text{SiO}_2$  and P to  $\text{P}_4\text{O}_{10}$ . Sometimes limestone is added as flux. Impurities of S, Si and P oxidise and pass into slag. The metal is removed and freed from slag by passing through rollers.



**Q. 30** How is copper extracted from low grade copper ores?

**Ans.** Copper is extracted from low grade copper ore using hydrometallurgy method. For this purpose, ore is leached out using bacteria. The solution containing  $\text{Cu}^{2+}$  is treated with scrap iron and  $\text{H}_2$ .

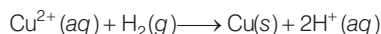

**Q. 31** Write two basic requirements for refining of a metal by Mond's process and by van Arkel Method.

**Ans.** Two basic requirements are

- (i) Metal should form volatile compound with available reagent.
- (ii) The volatile compound should be easily decomposable so that it can be recovered easily.
  - (a) **Mond's process** includes conversion of Ni to  $\text{Ni}(\text{CO})_4$  and then decomposition of  $\text{Ni}(\text{CO})_4$  to Ni.

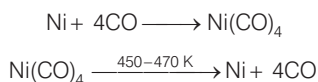

- (b) **van Arkel method** includes conversion of Zr to volatile  $\text{ZrI}_4$  and then decomposition of  $\text{ZrI}_4$  to Zr and  $\text{I}_2$ .

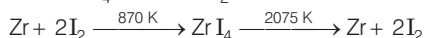

**Q. 32** Although carbon and hydrogen are better reducing agents but they are not used to reduce metallic oxides at high temperatures. Why?

**Ans.** Because at high temperatures, carbon and hydrogen react with metals to form carbides and hydrides respectively. So, carbon and hydrogen are not better reducing agents to reduce metallic oxide.

**Q. 33** How do we separate two sulphide ores by froth floatation method? Explain with an example.

**Ans.** Two sulphide ores can be separated by adjusting the proportion of oil and water or by using depressants, e.g., if an ore contains ZnS and PbS both, a depressant NaCN is added during froth floatation. It forms a complex with ZnS and prevents it from coming into froth. PbS comes into the froth and thus separated.

**Q. 34** The purest form of iron is prepared by oxidising impurities from cast iron in a reverberatory furnace. Which iron ore is used to line the furnace? Explain by giving reaction.

**Ans.** (a) Haematite ( $\text{Fe}_2\text{O}_3$ ) ore is used to line the furnace.



**Q. 35** The mixture of compounds A and B is passed through a column of  $\text{Al}_2\text{O}_3$  by using alcohol as eluant. Compound A is eluted in preference to compound B. Which of the compounds A or B, is more readily adsorbed on the column?

**Ans.** Compounds which are adsorbed to the more extent comes out later while the another one which absorbed to the less extent comes out readily. Since, compound 'A' comes out before compound 'B', the compound 'B' is more readily adsorbed on the column.

**Q. 36** Why is sulphide ore of copper heated in a furnace after mixing with silica?

**Ans.** Silica (flux) being an acidic flux removes the impurities of iron oxide the basic impurity, by reacting with it. Thus, iron silicate (slag) is formed.

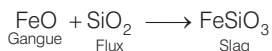

**Q. 37** Why are sulphide ores converted to oxide before reduction?

**Ans.** This is because oxides are reduced to metals easily while sulphides are not. So, sulphide ores are converted to oxide before reduction.

**Q. 38** Which method is used for refining Zr and Ti? Explain with equation.

**Ans.** Zr and Ti are refined by van Arkel method. It involves 2 steps

(a) **Formation of iodide** e.g., zirconium

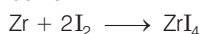

(b) **Decomposition of iodide**

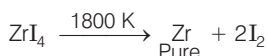

**Q. 39** What should be the considerations during the extraction of metals by electrochemical method?

**Ans.** During extraction of metals by electrochemical method the following two points must be considered

- Reactivity of metals** If the metals are quite reactive and are expected to react with water then the metals should be extracted by the electrolysis of their purified molten ore rather than their aqueous solution.
- Suitability of electrodes** The electrodes selected should not react with the product of electrolysis. If at all they react, then the electrodes must be made up of a material which is quite cheap since their periodic replacement should not increase the cost of the process.

**Q. 40** What is the role of flux in metallurgical processes?

**Ans.** Role of flux in metallurgical process

- Flux is used to remove the gangue by combining with it. Thus, slag formation takes place.
- It makes the molten mass more conducting.

**Q. 41** How are metals used as semiconductors refined? What is the principle of the method used like germanium, silicon etc?

**Ans.** Metals of high grade like germanium, silicon etc., used as semiconductors are refined by zone refining method.

**Principle** This method is based upon the principle that impurities are more soluble in molten state of metal than in solid state.

**Q. 42** Write down the reactions taking place in blast furnace related to the metallurgy of iron in the temperature range 500-800 K.

**Ans.** Chemical reactions occurring in blast furnace related to the metallurgy of iron in the temperature range 500-800 K are

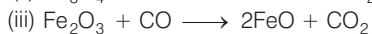
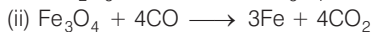
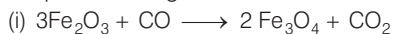

**Q. 43** Give two requirements for vapour phase refining.

**Ans.** Two requirements for vapour phase refining are

- (i) The metal should form a volatile compound with an available reagent.
- (ii) The volatile compound should be easily recovered by decomposition.

**Q. 44** Write the chemical reactions involved in the extraction of gold by cyanide process. Also give the role of zinc in the extraction.

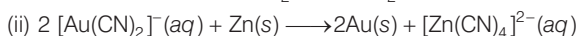
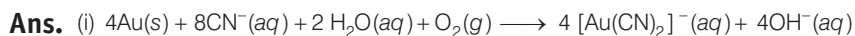

Zinc acts as a reducing agent in this reaction.

## Matching The Columns

**Q. 45** Match the items of Column I with items of Column II and assign the correct code.

Column I	Column II
A. Pendulum	1. Chrome steel
B. Malachite	2. Nickel steel
C. Calamine	3. $Na_3AlF_6$
D. Cryolite	4. $CuCO_3 \cdot Cu(OH)_2$
	5. $ZnCO_3$

**Codes**

A B C D

(a) 1 2 3 4

(c) 2 3 4 5

A B C D

(b) 2 4 5 3

(d) 4 5 3 2

**Ans. (b)** A.  $\rightarrow$ (2) B.  $\rightarrow$ (4) C.  $\rightarrow$ (5) D.  $\rightarrow$ (3)

A. Pendulum is made up of nickel steel.

B. Molecular formula of malachite is  $CuCO_3 \cdot Cu(OH)_2$ .

C. Molecular formula of calamine is  $ZnCO_3$ .

D. Molecular formula of cryolite is  $Na_3AlF_6$ .

**Q. 46** Match the items of Column I with the items of Column II and assign the correct code.

Column I	Column II
A. Coloured bands	1. Zone refining
B. Impure metal to volatile complex	2. Fractional distillation
C. Purification of Ge and Si	3. Mond's process
D. Purification of mercury	4. Chromatography
	5. Liqutation

**Codes**

A B C D  
 (a) 1 2 4 5  
 (c) 3 4 2 1

A B C D  
 (b) 4 3 1 2  
 (d) 5 4 3 2

**Ans. (b)** A. → (4) B. → (3) C. → (1) D. → (2)

- A. Coloured bands are observed in chromatography.  
 B. Impure metal is converted to volatile complex by using Mond's process.  
 C. Purification of Ge and Si are purified by zone refining method.  
 D. Purification of mercury is done by fractional distillation.

**Q. 47** Match items of Column I with the items of Column II and assign the correct code.

Column I	Column II
A. Cyanide process	1. Ultrapure Ge
B. Froth floatation process	2. Dressing of ZnS
C. Electrolytic reduction	3. Extraction of Al
D. Zone refining	4. Extraction of Au
	5. Purification of Ni

**Codes**

A B C D  
 (a) 4 2 3 1  
 (c) 1 2 3 4

A B C D  
 (b) 2 3 1 5  
 (d) 3 4 5 1

**Ans. (a)** A. → (4) B. → (2) C. → (3) D. → (1)

- A. Cyanide process is used for extraction of Au through formation of anionic complex  $[\text{Au}(\text{CN})_2]^-$ .  
 B. Froth floatation process is used for dressing of ZnS.  
 C. Electrolytic reduction method is used for extraction of aluminium. Graphite electrode is used for this purpose.  
 D. Zone-refining is used for purification of Ge.

**Q. 48** Match the items of Column I with the items of Column II and assign the correct code.

Column I	Column II
A. Sapphire	1. $\text{Al}_2\text{O}_3$
B. Sphalerite	2. NaCN
C. Depressant	3. Co
D. Corundum	4. ZnS
	5. $\text{Fe}_2\text{O}_3$

**Codes**

A	B	C	D	A	B	C	D
(a) 3	4	2	1	(b) 5	4	3	2
(c) 2	3	4	5	(d) 1	2	3	4

**Ans. (a)** A. → (3) B. → (4) C. → (2) D. → (1)

- A. Sapphire is a gemstone which contain Co.  
 B. Molecular formula of sphalerite is ZnS.  
 C. NaCN is used as a depressant in froth floatation method.  
 D. Molecular formula of corundum is  $\text{Al}_2\text{O}_3$ .

**Q.49** Match the items of Column I with items of Column II and assign the correct code.

Column I	Column II
A. Blistered Cu	1. Aluminium
B. Blast furnace	2. $2\text{Cu}_2\text{O} + \text{Cu}_2\text{S} \longrightarrow 6\text{Cu} + \text{SO}_2$
C. Reverberatory furnace	3. Iron
D. Hall-Heroult process	4. $\text{FeO} + \text{SiO}_2 \longrightarrow \text{FeSiO}_3$
	5. $2\text{Cu}_2\text{S} + 3\text{O}_2 \longrightarrow 2\text{Cu}_2\text{O} + 2\text{SO}_2$

**Codes**

A	B	C	D	A	B	C	D
(a) 2	3	4	1	(b) 1	2	3	5
(c) 5	4	3	2	(d) 4	5	3	2

**Ans. (a)** A. → (2) B. → (3) C. → (4) D. → (1)

- A. Blistered Cu can be prepared by means of following chemical reaction  

$$2\text{Cu}_2\text{O} + \text{Cu}_2\text{S} \longrightarrow 6\text{Cu} + \text{SO}_2$$

B. Iron is extracted by using blast furnace.

C. In reverberatory furnace formation of slag occurs as

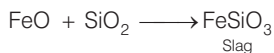

D. Hall-Heroult process is used for extraction of aluminium.

## Assertion and Reason

*In the following questions a statement of Assertion (A) followed by a statement of Reason (R) is given. Choose the correct answer out of the following choices.*

- (a) Both assertion and reason are true and reason is the correct explanation of assertion.
- (b) Both assertion and reason are true but reason is not the correct explanation of assertion.
- (c) Assertion is true but reason is false.
- (d) Assertion is false but reason is true.
- (e) Assertion and reason both are wrong.

**Q. 50** Assertion (A) Nickel can be purified by Mond's process.

Reason (R)  $\text{Ni}(\text{CO})_4$  is a volatile compound which decomposes at 460 K to give pure Ni.

**Ans. (a)** Both assertion and reason are true and reason is the correct explanation of assertion.  
Nickel can be purified by Mond's process in which formation of a volatile compound  $\text{Ni}(\text{CO})_4$  takes place which further decomposes to Ni at 460K.

**Q. 51** Assertion (A) Zirconium can be purified by van Arkel method.

Reason (R)  $\text{ZrI}_4$  is volatile and decomposes at 1800K.

**Ans. (a)** Both assertion and reason are true and reason is the correct explanation of assertion.  
Zirconium can be purified by van Arkel method which include formation of volatile  $\text{ZrI}_4$  which decomposes at 1800 K to Zr.

**Q. 52** Assertion (A) Sulphide ores are concentrated by froth floatation method.

Reason (R) Cresols stabilise the froth in froth floatation method.

**Ans. (b)** Both assertion and reason are true but reason is not the correct explanation of assertion.  
Sulphide ores are concentrated by froth floatation method. Sulphide ore particles are preferentially wetted by oil, become lighter and rise to the surface along with the froth while gangue particles are preferentially wetted by water, become heavier and thus settle down at the bottom of the tank and cresols stabilise the froth in froth floatation method.  
Formation of froth is main reason for extraction of metal. Metal ore comes out along with froth.

**Q. 53** Assertion (A) Zone refining method is very useful for producing semiconductors.

Reason (R) Semiconductors are of high purity.

**Ans. (b)** Both assertion and reason are true but reason is not the correct explanation of assertion.  
Zone refining method is very useful for producing semiconductors of high purity as in this process pure metal crystallises while impurities pass on into adjacent molten zone when impure metal rod is heated.

**Q. 54** Assertion (A) Hydrometallurgy involves dissolving the ore in a suitable reagent followed by precipitation by a more electropositive metal.

Reason (R) Copper is extracted by hydrometallurgy.

**Ans. (b)** Assertion and reason both are correct but reason is not the correct explanation of assertion.

Hydrometallurgy involves dissolving the ore in suitable reagent followed by precipitation with the help of more electropositive metal in which pure metal is get replaced by more electropositive metal.

## Long Answer Type Questions

**Q. 55** Explain the following

- $\text{CO}_2$  is a better reducing agent below 710 K whereas CO is a better reducing agent above 710 K.
- Generally sulphide ores are converted into oxides before reduction.
- Silica is added to the sulphide ore of copper in the reverberatory furnace.
- Carbon and hydrogen are not used as reducing agents at high temperatures.
- Vapour phase refining method is used for the purification of Ti.

### 💡 Thinking Process

*This problem is based on concept of Ellingham diagrams and purification of metal.*

**Ans.** (a) As shown in Ellingham diagram which relates Gibbs free energy and temperature at below 710 K.

$\Delta G_{(\text{C},\text{CO}_2)} < \Delta G_{(\text{C},\text{CO})}$  So,  $\text{CO}_2$  is a better reducing agent than CO while above 710K it becomes a very good reducing agent.

- Generally, sulphide ores are converted to oxides before reduction as reduction of oxides can easily be done using C or CO depending upon metal ore and temperature.
- Silica is a flux added to the sulphide ore of copper in the reverberatory furnace leading to the formation of slag

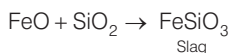

- Carbon and hydrogen are not used as reducing agents at high temperature. At high temperature carbon and hydrogen readily form their carbides and hydrides respectively.
- Vapour phase refining method is used for the purification of Ti as







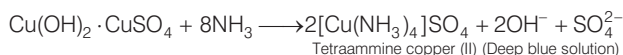

**Q. 3** In a cyclotrimetaphosphoric acid molecule, how many single and double bonds are present?

- (a) 3 double bonds; 9 single bonds  
 (b) 6 double bonds; 6 single bonds  
 (c) 3 double bonds; 12 single bonds  
 (d) Zero double bond; 12 single bonds

**Ans. (c)** Cyclotrimetaphosphoric acid contains three double bonds and 9 single bonds as shown below

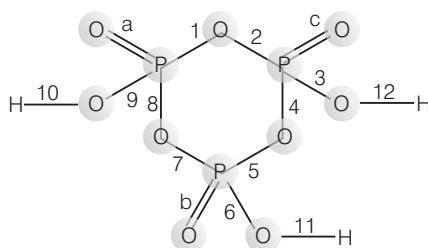

**Cyclotrimetaphosphoric acid (HPO<sub>3</sub>)<sub>3</sub>**

a, b, c are three  $\pi$  bonds and numerics 1 to 12 are sigma ( $\sigma$ ) bonds.

**Q. 4** Which of the following elements can be involved in  $p\pi - d\pi$  bonding?

- (a) Carbon (b) Nitrogen  
 (c) Phosphorus (d) Boron

**Ans. (c)** Among given four elements *i.e.*, carbon, nitrogen, phosphorus and boron. Only phosphorus has vacant *d*-orbit so only phosphorus has ability to form  $p\pi - d\pi$  bonding.

**Q. 5** Which of the following pairs of ions are isoelectronic and isostructural?

- (a)  $\text{CO}_3^{2-}$ ,  $\text{NO}_3^-$  (b)  $\text{ClO}_3^-$ ,  $\text{CO}_3^{2-}$  (c)  $\text{SO}_3^{2-}$ ,  $\text{NO}_3^-$  (d)  $\text{ClO}_3^-$ ,  $\text{SO}_3^{2-}$

**Ans. (a)** Compounds having same value of total number of electrons are known as isoelectronic.

For  $\text{CO}_3^{2-}$

$$\begin{aligned} \text{Total number of electrons} &= 6 + 8 \times 3 + 2 \\ &= 6 + 24 + 2 \\ &= 32 \end{aligned}$$

For  $\text{NO}_3^-$

$$\begin{aligned} \text{Total number of electrons} &= 7 + 8 \times 3 + 1 \\ &= 7 + 25 \\ &= 32 \end{aligned}$$

Hence,  $\text{CO}_3^{2-}$  and  $\text{NO}_3^-$  are isoelectronic. These two ions have similar structure so they are isostructural.

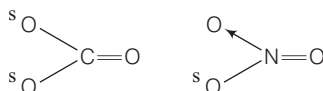

Both have triangular planar structure as in both the species carbon and nitrogen are  $sp^2$  hybridised. Hence, (a) is the correct choice.

**Q. 6** Affinity for hydrogen decreases in the group from fluorine to iodine. Which of the halogen acids should have highest bond dissociation enthalpy?

- (a) HF (b) HCl (c) HBr (d) HI

**Ans. (a)** HF | On moving top to bottom  
 HCl | • Size of halogen atom increases  
 HBr | • H-X bond length increases  
 HI | • Bond dissociation enthalpy decreases

**Q. 7** Bond dissociation enthalpy of E—H (E= element) bonds is given below. Which of the compounds will act as strongest reducing agent?

Compound	NH <sub>3</sub>	PH <sub>3</sub>	AsH <sub>3</sub>	SbH <sub>3</sub>
$\Delta_{\text{diss}}(\text{E—H}) / \text{kJ mol}^{-1}$	389	322	297	255

- (a) NH<sub>3</sub> (b) PH<sub>3</sub> (c) AsH<sub>3</sub> (d) SbH<sub>3</sub>

**Ans. (d)** On moving top to bottom, size of central atom increases. Bond length of X—H bond increases and bond dissociation energy decreases. Hence, reducing nature increases.

NH<sub>3</sub> |  
 PH<sub>3</sub> | • Bond length increases  
 AsH<sub>3</sub> | • Bond dissociation energy decreases  
 SbH<sub>3</sub> | • Reducing character increases  
 Hence, SbH<sub>3</sub> is act as strongest reducing agent among these.

**Q. 8** On heating with concentrated NaOH solution in an inert atmosphere of CO<sub>2</sub>, white phosphorus gives a gas. Which of the following statement is incorrect about the gas?

- (a) It is highly poisonous and has smell like rotten fish  
 (b) It's solution in water decomposes in the presence of light  
 (c) It is more basic than NH<sub>3</sub>  
 (d) It is less basic than NH<sub>3</sub>

**Ans. (c)** White phosphorous on reaction with NaOH solution in the presence of inert atmosphere of CO<sub>2</sub> it produces phosphine gas which is less basic than NH<sub>3</sub>.

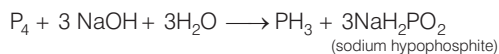

**Q. 9** Which of the following acids forms three series of salts?

- (a) H<sub>3</sub>PO<sub>2</sub> (b) H<sub>3</sub>BO<sub>3</sub> (c) H<sub>3</sub>PO<sub>4</sub> (d) H<sub>3</sub>PO<sub>3</sub>

**Ans. (c)** Structure of H<sub>3</sub>PO<sub>4</sub> is

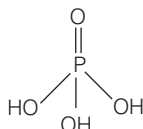

H<sub>3</sub>PO<sub>4</sub> has 3—OH groups *i.e.*, has three ionisable H-atoms and hence forms three series of salts. These three possible series of salts for H<sub>3</sub>PO<sub>4</sub> are as follows



**Q. 10** Strong reducing behaviour of  $\text{H}_3\text{PO}_2$  is due to

- (a) low oxidation state of phosphorus
- (b) presence of two —OH groups and one P—H bond
- (c) presence of one —OH group and two P—H bonds
- (d) high electron gain enthalpy of phosphorus

**Ans. (c)** Strong reducing behaviour of  $\text{H}_3\text{PO}_2$  is due to presence of two P—H bonds and one P—OH bond

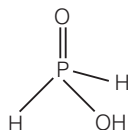

**Hypophosphorous following  
(Monobasic)**

**Q. 11** On heating lead nitrate forms oxides of nitrogen and lead. The oxides formed are .....

- (a)  $\text{N}_2\text{O}$ , PbO
- (b)  $\text{NO}_2$ , PbO
- (c) NO, PbO
- (d) NO,  $\text{PbO}_2$

**Ans. (b)** On heating lead nitrate it produces brown coloured nitrogen dioxide ( $\text{NO}_2$ ) and lead (II) oxide.

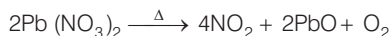

**Q. 12** Which of the following elements does not show allotropy?

- (a) Nitrogen
- (b) Bismuth
- (c) Antimony
- (d) Arsenic

**Ans. (a)** Nitrogen does not show allotropy due to its weak N—N single bond. Therefore, ability of nitrogen to form polymeric structure or more than one structure or form become less. Hence, nitrogen does not show allotropy.

**Q. 13** Maximum covalency of nitrogen is .....

- (a) 3
- (b) 5
- (c) 4
- (d) 6

**Ans. (c)** Maximum covalency of nitrogen is 4 in which one electron is made available by s-orbital and 3 electrons are made available by p orbitals. Hence, total four electrons are available for bonding.

**Q. 14** Which of the following statements is wrong?

- (a) Single N—N bond is stronger than the single P—P bond.
- (b)  $\text{PH}_3$  can act as a ligand in the formation of coordination compound with transition elements.
- (c)  $\text{NO}_2$  is paramagnetic in nature.
- (d) Covalency of nitrogen in  $\text{N}_2\text{O}_5$  is four.

**Ans. (a)** True statement is that single N — N bond is weaker than the single P — P bond. This is why phosphorous show allotropy but nitrogen does not.

- (i)  $\text{PH}_3$  acts as a ligand in the formation of coordination compound due to presence of lone pair of electrons.

- (ii)  $\text{NO}_2$  is paramagnetic in nature due to presence of one unpaired electron.  
Structure of  $\text{NO}_2$  is

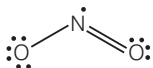

- (iii) Covalency of nitrogen in  $\text{N}_2\text{O}_5$  is 4.

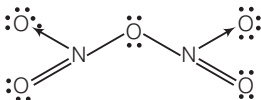

**Q. 15** A brown ring is formed in the ring test for  $\text{NO}_3^-$  ion. It is due to the formation of

- (a)  $[\text{Fe}(\text{H}_2\text{O})_5(\text{NO})]^{2+}$  (b)  $\text{FeSO}_4 \cdot \text{NO}_2$   
(c)  $[\text{Fe}(\text{H}_2\text{O})_4(\text{NO})_2]^{2+}$  (d)  $\text{FeSO}_4 \cdot \text{HNO}_3$

**Ans. (a)** When freshly prepared solution of  $\text{FeSO}_4$  is added in a solution containing  $\text{NO}_3^-$  ion, it leads to formation of a brown coloured complex. This is known as brown ring test of nitrate.

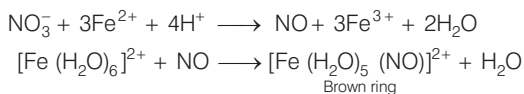

**Q. 16** Elements of group- 15 form compounds in +5 oxidation state. However, bismuth forms only one well characterised compound in +5 oxidation state. The compound is

- (a)  $\text{Bi}_2\text{O}_5$  (b)  $\text{BiF}_5$   
(c)  $\text{BiCl}_5$  (d)  $\text{Bi}_2\text{S}_5$

**Ans. (b)** Stability of + 5 oxidation state decreases top to bottom and + 3 oxidation state increases top to bottom due to inert pair effect. Meanwhile compound having + 5 oxidation state of Bi is  $\text{BiF}_5$ . It is due to smaller size and high electronegativity of fluorine.

**Q. 17** On heating ammonium dichromate and barium azide separately we get

- (a)  $\text{N}_2$  in both cases  
(b)  $\text{N}_2$  with ammonium dichromate and  $\text{NO}$  with barium azide  
(c)  $\text{N}_2\text{O}$  with ammonium dichromate and  $\text{N}_2$  with barium azide  
(d)  $\text{N}_2\text{O}$  with ammonium dichromate and  $\text{NO}_2$  with barium azide

**Ans. (a)** On heating ammonium dichromate and barium azide it produces  $\text{N}_2$  gas separately.

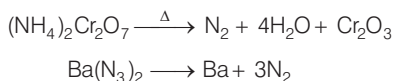

**Q. 18** In the preparation of  $\text{HNO}_3$ , we get  $\text{NO}$  gas by catalytic oxidation of ammonia. The moles of  $\text{NO}$  produced by the oxidation of two moles of  $\text{NH}_3$  will be .....

- (a) 2 (b) 3 (c) 4 (d) 6

**Ans. (a)** Two moles of  $\text{NH}_3$  will produce 2 moles of  $\text{NO}$  on catalytic oxidation of ammonia in preparation of nitric acid.

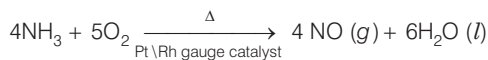

**Q. 19** The oxidation state of central atom in the anion of compound  $\text{NaH}_2\text{PO}_2$  will be .....

- (a) + 3                      (b) + 5                      (c) + 1                      (d) - 3

**Ans. (c)** Let oxidation state of P in  $\text{NaH}_2\text{PO}_2$  is  $x$ .

$$\begin{aligned} 1 + 2 \times 1 + x + 2 \times -2 &= 0 \\ 1 + 2 + x - 4 &= 0 \\ + x - 1 &= 0 \\ x &= + 1 \end{aligned}$$

**Q. 20** Which of the following is not tetrahedral in shape?

- (a)  $\text{NH}_4^+$                       (b)  $\text{SiCl}_4$                       (c)  $\text{SF}_4$                       (d)  $\text{SO}_4^{2-}$

**Ans. (c)**  $\text{SF}_4$  has sea-saw shaped as shown below

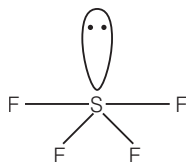

It has trigonal bipyramidal geometry having  $sp^3d$  hybridisation.

**Q. 21** Which of the following are peroxyacids of sulphur?

- (a)  $\text{H}_2\text{SO}_5$  and  $\text{H}_2\text{S}_2\text{O}_8$                       (b)  $\text{H}_2\text{SO}_5$  and  $\text{H}_2\text{S}_2\text{O}_7$   
 (c)  $\text{H}_2\text{S}_2\text{O}_7$  and  $\text{H}_2\text{S}_2\text{O}_8$                       (d)  $\text{H}_2\text{S}_2\text{O}_6$  and  $\text{H}_2\text{S}_2\text{O}_7$

**Ans. (a)** Peroxyacids of sulphur must contain one  $\text{—O—O—}$  bond as shown below

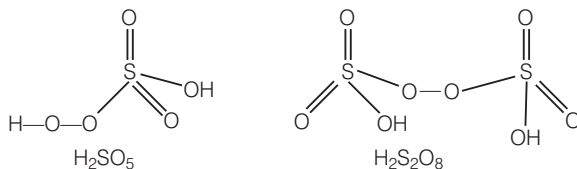

**Q. 22** Hot conc.  $\text{H}_2\text{SO}_4$  acts as moderately strong oxidising agent. It oxidises both metals and non-metals. Which of the following element is oxidised by conc.  $\text{H}_2\text{SO}_4$  into two gaseous products?

- (a) Cu                      (b) S                      (c) C                      (d) Zn

**Ans. (c)**  $\text{H}_2\text{SO}_4$  is a moderately strong oxidising agent which oxidises both metals and non-metals as shown below

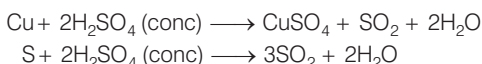

While carbon on oxidation with  $\text{H}_2\text{SO}_4$  produces two types of oxides  $\text{CO}_2$  and  $\text{SO}_2$ .

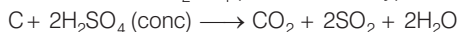



**Q. 26** Reduction potentials of some ions are given below. Arrange them in decreasing order of oxidising power.

Ion	$\text{ClO}_4^-$	$\text{IO}_4^-$	$\text{BrO}_4^-$
Reduction potential $E^-/V$	$E^\circ = 1.19\text{ V}$	$E^s = 1.65\text{ V}$	$E^s = 1.74\text{ V}$

- (a)  $\text{ClO}_4^- > \text{IO}_4^- > \text{BrO}_4^-$                       (b)  $\text{IO}_4^- > \text{BrO}_4^- > \text{ClO}_4^-$   
 (c)  $\text{BrO}_4^- > \text{IO}_4^- > \text{ClO}_4^-$                       (d)  $\text{BrO}_4^- > \text{ClO}_4^- > \text{IO}_4^-$

**Thinking Process**

*This problem is based on concept of standard reduction potential of species and oxidising property.*

**Ans. (c)** Greater the SRP value of species higher will be its oxidising power.

Species	$E^\circ_{\text{cell}}$	
$\text{ClO}_4^-$	1.19V	↓ SRP of species increases. Oxidising power increase.
$\text{IO}_4^-$	1.65V	
$\text{BrO}_4^-$	1.74V	

Here, SRP = standard reduction potential.

**Q. 27** Which of the following is isoelectronic pair?

- (a)  $\text{ICl}_2$ ,  $\text{ClO}_2$                                       (b)  $\text{BrO}_2^-$ ,  $\text{BrF}_2^+$   
 (c)  $\text{ClO}_2$ ,  $\text{BrF}$                                       (d)  $\text{CN}^-$ ,  $\text{O}_3$

**Ans. (b)** Isoelectronic pair have same number of electrons

	$\text{BrO}_2^-$	$\text{BrF}_2^+$
<b>Total number of electrons</b>	$= 35 + 2 \times 8 + 1 = 52$	$= 35 + 9 \times 2 - 1 = 52$

Hence, (b) is the correct choice, while in another cases this value is not equal.

<b><math>\text{ICl}_2</math></b>	<b><math>\text{ClO}_2</math></b>
$53 + 2 \times 17 = 87$	$17 + 16 = 33$
<b><math>\text{ClO}_2</math></b>	<b><math>\text{BrF}</math></b>
$17 + 16 = 33$	$35 + 9 = 44$
<b><math>\text{CN}^-</math></b>	<b><math>\text{O}_3</math></b>
$= 6 + 7 + 1 = 14$	$= 8 \times 3 = 24$

Hence, only (b) is the correct choice.

## Multiple Choice Questions (More Than One Options)

**Q. 28** If chlorine gas is passed through hot **NaOH** solution, two changes are observed in the oxidation number of chlorine during the reaction. These are ..... and .....

- (a) 0 to +5                      (b) 0 to +3                      (c) 0 to -1                      (d) 0 to +1

**Ans. (a, c)**

When chlorine gas is passed through hot NaOH solution it produces NaCl and NaClO<sub>3</sub>.

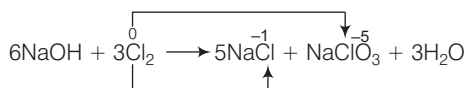

Oxidation state varies from 0 to -1 and 0 to +5.

Hence, (a) and (c) are correct choices.

**Q. 29** Which of the following options are not in accordance with the property mentioned against them?

- (a)  $\text{F}_2 > \text{Cl}_2 > \text{Br}_2 > \text{I}_2$                       Oxidising power  
 (b)  $\text{MI} > \text{MBr} > \text{MCl} > \text{MF}$                       Ionic character of metal halide  
 (c)  $\text{F}_2 > \text{Cl}_2 > \text{Br}_2 > \text{I}_2$                       Bond dissociation enthalpy  
 (d)  $\text{HI} < \text{HBr} < \text{HCl} < \text{HF}$                       Hydrogen-halogen bond strength

**Ans. (b, c)**

$\text{F}_2 > \text{Cl}_2 > \text{Br}_2 > \text{I}_2$  As ability to gain electron increases oxidising property increases. Here, F is the most electronegative element having highest value of SRP hence it has highest oxidising power.

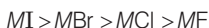

This is the incorrect order of ionic character of metal halide.

Correct order can be written as



As electronegativity difference between metal and halogen increases ionic character increases.

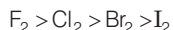

This is incorrect order of bond dissociation energy. Correct order is  $\text{Cl}_2 > \text{Br}_2 > \text{F}_2 > \text{I}_2$  due to electronic repulsion among lone pairs in F<sub>2</sub> molecule.

**Q. 30** Which of the following is correct for P<sub>4</sub> molecule of white phosphorus?

- (a) It has 6 lone pairs of electrons                      (b) It has six P — P single bonds  
 (c) It has three P — P single bonds                      (d) It has four lone pairs of electrons

**Ans. (b, d)**

Structure of P<sub>4</sub> molecule can be represented as

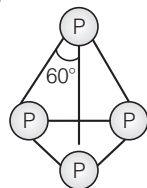

It has total four lone pairs of electrons situated at each P-atom.

It has six P—P single bond.



**Q. 31** Which of the following statements are correct?

- Among halogens, radius ratio between iodine and fluorine is maximum.
- Leaving F — F bond, all halogens have weaker X — X bond than X — X' bond in interhalogens.
- Among interhalogen compounds maximum number of atoms are present in iodine fluoride.
- Interhalogen compounds are more reactive than halogen compounds.

**Ans. (a, c, d)**

- Among halogens, radius ratio between iodine and fluorine is maximum because iodine has maximum radius and fluorine has minimum radius.
- It can be correctly stated as in general interhalogen compounds are more reactive than halogen. This is because X — X' bond in interhalogen is weaker than X — X bond in halogens except F—F bond.
- Among interhalogen compounds maximum number of atoms are present in iodine fluoride because radius ratio of iodine and fluorine has maximum value.
- Interhalogen compounds are more reactive than halogen due to weaker X — X' bond as compared to X — X of halogen compounds.

**Q. 32** Which of the following statements are correct for SO<sub>2</sub> gas?

- It acts as bleaching agent in moist conditions.
- Its molecule has linear geometry.
- Its dilute solution is used as disinfectant.
- It can be prepared by the reaction of dilute H<sub>2</sub>SO<sub>4</sub> with metal sulphide.

**Ans. (a, c)**

- In moist condition SO<sub>2</sub> gas acts as a bleaching agent.  
e.g., it converts Fe (III) to Fe (II) ion and decolourises acidified KMnO<sub>4</sub> (VII).

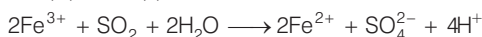

- is incorrect it has bent structure.

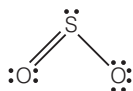

- Its dilute solution is used as a disinfectant.
- It can be prepared by the reaction of O<sub>2</sub> with sulphide ore,

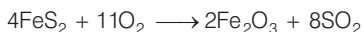

while metal on treatment with H<sub>2</sub>SO<sub>4</sub> produces H<sub>2</sub>S.

Hence, options (a) and (c) are correct choices.

**Q. 33** Which of the following statements are correct?

- All the three N — O bond lengths in HNO<sub>3</sub> are equal.
- All P — Cl bond lengths in PCl<sub>5</sub> molecule in gaseous state are equal
- P<sub>4</sub> molecule in white phosphorus have angular strain therefore white phosphorus is very reactive
- PCl<sub>5</sub> is ionic in solid state in which cation is tetrahedral and anion is octahedral.

**Ans. (c, d)**

- (a) All the three N—O bond lengths in  $\text{HNO}_3$  are not equal.  
 (b) All P—Cl bond lengths in  $\text{PCl}_5$  molecule in gaseous state are not equal. Axial bond is longer than equatorial bond.  
 (c)  $\text{P}_4$  molecule in white phosphorous have angular strain therefore white phosphorous is very reactive.  
 (d)  $\text{PCl}_5$  is ionic in solid state in which cation is tetrahedral and anion is octahedral.

**Q. 34** Which of the following orders are correct as per the properties mentioned against each?

- (a)  $\text{As}_2\text{O}_3 < \text{SiO}_2 < \text{P}_2\text{O}_3 < \text{SO}_2$  Acid strength.  
 (b)  $\text{AsH}_3 < \text{PH}_3 < \text{NH}_3$  Enthalpy of vaporisation.  
 (c)  $\text{S} < \text{O} < \text{Cl} < \text{F}$  More negative electron gain enthalpy.  
 (d)  $\text{H}_2\text{O} > \text{H}_2\text{S} > \text{H}_2\text{Se} > \text{H}_2\text{Te}$  Thermal stability.

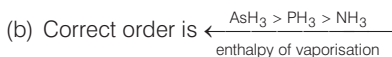
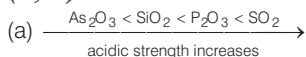
**Ans. (a, d)**

- (c)  $\text{S} < \text{O} < \text{Cl} < \text{F}$  More negative electron gain enthalpy  
 (d)  $\text{H}_2\text{O} > \text{H}_2\text{S} > \text{H}_2\text{Se} > \text{H}_2\text{Te}$  Thermal stability decreases on moving top to bottom due to increase in its bond length.

**Q. 35** Which of the following statements are correct?

- (a) S—S bond is present in  $\text{H}_2\text{S}_2\text{O}_6$   
 (b) In peroxosulphuric acid ( $\text{H}_2\text{SO}_5$ ) sulphur is in + 6 oxidation state  
 (c) Iron powder along with  $\text{Al}_2\text{O}_3$  and  $\text{K}_2\text{O}$  is used as a catalyst in the preparation of  $\text{NH}_3$  by Haber's process  
 (d) Change in enthalpy is positive for the preparation of  $\text{SO}_3$  by catalytic oxidation of  $\text{SO}_2$

**Ans. (a, b)**

- (a) Structure of  $\text{H}_2\text{S}_2\text{O}_6$  is as shown below

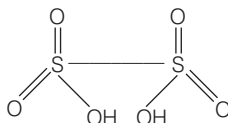

It contains one S—S bond.

- (b) In peroxosulphuric acid ( $\text{H}_2\text{SO}_5$ ) sulphur is in + 6 oxidation state.  
 Structure of  $\text{H}_2\text{SO}_5$  is

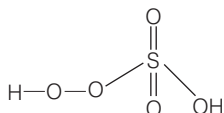

Let oxidation state of S =  $x$

$$2 \times (+1) + x + 3 \times (-2) + 2 \times (-1) = 0$$

$$x - 6 = 0$$

$$x = 6$$

- (c) During preparation of ammonia, iron oxide with small amount of  $K_2O$  and  $Al_2O_3$  is used as a catalyst to increase the rate of attainment of equilibrium.
- (d) Change in enthalpy is negative for preparation of  $SO_3$  by catalytic oxidation of  $SO_2$ .

**Q. 36** In which of the following reactions conc.  $H_2SO_4$  is used as an oxidising reagent?

- (a)  $CaF_2 + H_2SO_4 \longrightarrow CaSO_4 + 2HF$
- (b)  $2HI + H_2SO_4 \longrightarrow I_2 + SO_2 + 2H_2O$
- (c)  $Cu + 2H_2SO_4 \longrightarrow CuSO_4 + SO_2 + 2H_2O$
- (d)  $NaCl + H_2SO_4 \longrightarrow NaHSO_4 + HCl$

**Ans. (b, c)**

In the above given four reactions, (b) and (c) represent oxidising behaviour of  $H_2SO_4$ . As we know that oxidising agent reduces itself as oxidation state of central atom decreases.

Here,

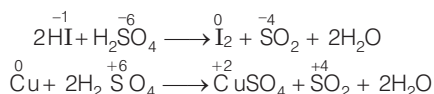

**Q. 37** Which of the following statements are true?

- (a) Only type of interactions between particles of noble gases are due to weak dispersion forces.
- (b) Ionisation enthalpy of molecular oxygen is very close to that of xenon.
- (c) Hydrolysis of  $XeF_6$  is a redox reaction.
- (d) Xenon fluorides are not reactive.

**Ans. (a, b)**

- (a) Only one type of interactions between particles of noble gases are due to weak dispersion forces.
- (b) Ionisation enthalpy of molecular oxygen is very close to that of xenon. This is the reason for the formation of xenon oxides.
- (c) Hydrolysis of  $XeF_6$  ( $\overset{+6}{Xe}\overset{-1}{F}_6 + 3\overset{+1}{H}\overset{-2}{O} \longrightarrow \overset{+6}{Xe}\overset{-2}{O}_3 + 3\overset{+1}{H}\overset{-1}{F}$ ) is not a redox reaction.
- (d) Xenon fluorides are highly reactive hydrolysis readily even by traces of water.

## Short Answer Type Questions

**Q. 38** In the preparation of  $\text{H}_2\text{SO}_4$  by Contact process, why is  $\text{SO}_3$  not absorbed directly in water to form  $\text{H}_2\text{SO}_4$ ?

**Ans.** In Contact process  $\text{SO}_3$  is not absorbed directly in water to form  $\text{H}_2\text{SO}_4$  because the reaction is highly exothermic, acid mist is formed. Hence, the reaction becomes difficult to handle.

**Note**

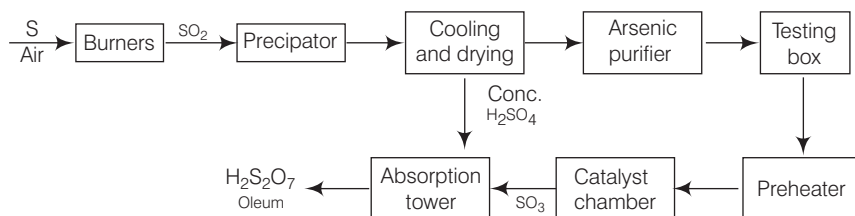

**Flow chart of Contact process**

**Q. 39** Write a balanced chemical equation for the reaction showing catalytic oxidation of  $\text{NH}_3$  by atmospheric oxygen.

**Ans.** Ammonia ( $\text{NH}_3$ ) on catalytic oxidation by atmospheric oxygen in presence of Rh/Pt gauge at 500K under pressure of 9 bar produces nitrous oxide.

Balanced chemical reaction can be written as

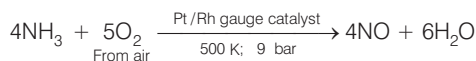

**Q. 40** Write the structure of pyrophosphoric acid.

**Ans.** Molecular formula of pyrophosphoric acid is  $\text{H}_4\text{P}_2\text{O}_7$  and its structure is as follows

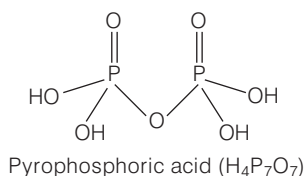

**Q. 41**  $\text{PH}_3$  forms bubbles when passed slowly in water but  $\text{NH}_3$  dissolves. Explain why?

**Ans.** Dissolution of  $\text{NH}_3$  and  $\text{PH}_3$  in water can be explained on the basis of H-bonding.  $\text{NH}_3$  forms H-bond with water so it is soluble but  $\text{PH}_3$  does not form H-bond with water so it remains as gas and forms bubble in water.

**Q. 42** In  $\text{PCl}_5$ , phosphorus is in  $sp^3d$  hybridised state but all its five bonds are not equivalent. Justify your answer with reason.

**Ans.** It has trigonal bipyramidal geometry, in which two Cl atoms occupy axial position while three occupy equatorial positions. All five P—Cl bonds are not identical. There are two types of bond lengths (i) Axial bond lengths (ii) Equatorial bond lengths

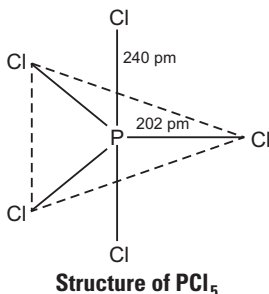

Thus, difference in bond length is due to fact that axial bond pairs suffer more repulsion as compared to equatorial bond pairs.

**Q. 43** Why is nitric oxide paramagnetic in gaseous state but the solid obtained on cooling it is diamagnetic?

**Ans.** In gaseous state,  $\text{NO}_2$  exists as a monomer which has one unpaired electron but in solid state, it dimerises to  $\text{N}_2\text{O}_4$  so no unpaired electron left. Therefore,  $\text{NO}_2$  is paramagnetic in gaseous state but diamagnetic in solid state.

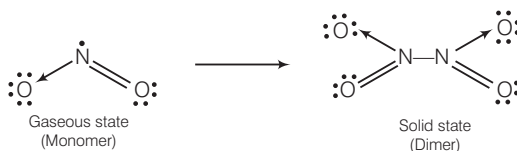

**Q. 44** Give one reason to explain why  $\text{ClF}_3$  exists but  $\text{FCl}_3$  does not exist?

**Ans.** Existence of  $\text{ClF}_3$  and  $\text{FCl}_3$  can be explained on the basis of size of central atom. Because fluorine is more electronegative as compared to chlorine and has smaller size. Thus, one large Cl atom can accommodate three smaller F atoms but reverse is not true.

**Q. 45** Out of  $\text{H}_2\text{O}$  and  $\text{H}_2\text{S}$ , which one has higher bond angle and why?

**Ans.** Bond angle of  $\text{H}_2\text{O}$  ( $\text{H}—\text{O}—\text{H} = 104.5^\circ$ ) is larger than that of  $\text{H}_2\text{S}$  ( $\text{H}—\text{S}—\text{H} = 92^\circ$ ) because oxygen is more electronegative than sulphur therefore, bond pair electron of  $\text{O}—\text{H}$  bond will be closer to oxygen and there will be more bond pair—bond pair repulsion between bond pairs of two  $\text{O}—\text{H}$  bonds.

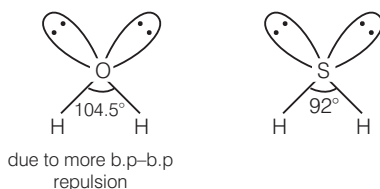

**Q. 46**  $\text{SF}_6$  is known but  $\text{SCl}_6$  is not. Why?

**Ans.** Fluorine atom is smaller in size so, six  $\text{F}^-$  ions can surround a sulphur atom. The case is not so with chlorine atom due to its large size. So,  $\text{SF}_6$  is known but  $\text{SCl}_6$  is not known due to interionic repulsion between larger  $\text{Cl}^-$  ions.

**Q. 47** On reaction with  $\text{Cl}_2$ , phosphorus forms two types of halides 'A' and 'B'. Halide 'A' is yellowish-white powder but halide 'B' is colourless oily liquid. Identify A and B and write the formulae of their hydrolysis products.

**Ans.** Phosphorus on reaction with  $\text{Cl}_2$  forms two types of halides A and B.

'A' is  $\text{PCl}_5$  and 'B' is  $\text{PCl}_3$ .

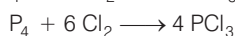
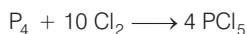

When 'A' and 'B' are hydrolysed

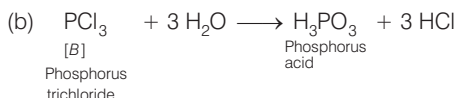
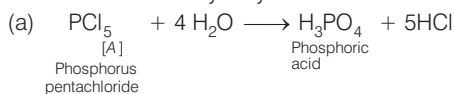

**Q. 48** In the ring test of  $\text{NO}_3^-$  ion,  $\text{Fe}^{2+}$  ion reduces nitrate ion to nitric oxide, which combines with  $\text{Fe}^{2+}$  (aq) ion to form brown complex. Write the reactions involved in the formation of brown ring.

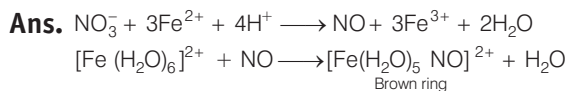

This test is known as brown ring test of nitrates generally used to identify the presence of nitrate ion in given solution.

**Q. 49** Explain why the stability of oxoacids of chlorine increases in the order given below.

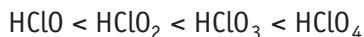

**Ans.** Oxygen is more electronegative than chlorine, therefore dispersal of negative charge present on chlorine increases from  $\text{ClO}^-$  to  $\text{ClO}_4^-$  ion because number of oxygen atoms attached to chlorine is increasing. Therefore, stability of ions will increase in the order given below

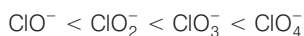

Due to increase in stability of conjugate base, acidic strength of corresponding acid increases in the same order

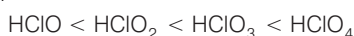

**Q. 50** Explain why ozone is thermodynamically less stable than oxygen?

**Ans.** Ozone is thermodynamically less stable than oxygen because its decomposition into oxygen results in the liberation of heat ( $\Delta H$  is negative) and an increase in entropy ( $\Delta S$  is positive). These two effects reinforce each other, resulting in large negative Gibbs energy change ( $\Delta G$ ) for its conversion into oxygen.



**Q. 53** Name three oxoacids of nitrogen. Write the disproportionation reaction of that oxoacid of nitrogen in which nitrogen is in + 3 oxidation state.

**Ans.** Three oxoacids of nitrogen having oxidation state + 3 are

(a)  $\text{HNO}_2$ , nitrous acid

(b)  $\text{HNO}_3$ , nitric acid

(c) Hyponitrous acid,  $\text{H}_2\text{N}_2\text{O}_2$

In  $\text{HNO}_2$ , N is in + 3 oxidation state

Disproportionation reaction



**Q. 54** Nitric acid forms an oxide of nitrogen on reaction with  $\text{P}_4\text{O}_{10}$ . Write the reaction involved. Also write the resonating structures of the oxide of nitrogen formed.

**Ans.**  $\text{P}_4\text{O}_{10}$  being a dehydrating agent, on reaction with  $\text{HNO}_3$  removes a molecule of water and forms anhydride of  $\text{HNO}_3$ .

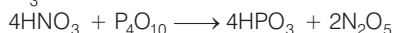

Resonating structures of  $\text{N}_2\text{O}_5$  are

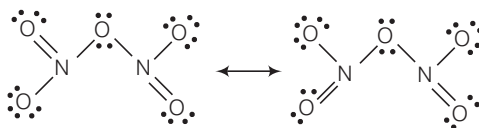

**Q. 55** (i) white phosphorus (ii) red phosphorus and (iii) black phosphorus. Write the difference between white red and black phosphorus on the basis of their structure and reactivity.

Phosphorus has three allotropic forms —

**Ans.**

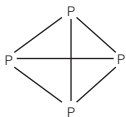
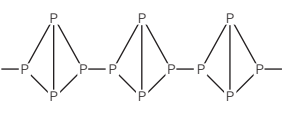
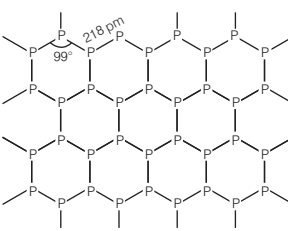
	White phosphorus	Red phosphorus	Black phosphorus
1.	It is less stable form of P	More stable than white P.	It is most stable form of P
2.	It is highly reactive. 	Less reactive than white P. 	It is least reactive. 
3.	It has regular tetrahedron structure.	It has polymeric structure.	It has a layered structure.



**Q. 56** Give an example to show the effect of concentration of nitric acid on the formation of oxidation product.

**Ans.** Effect of concentration of nitric acid on the formation of oxidation product can be understood by its reaction with conc  $\text{HNO}_3$ . Dilute and concentrated nitric acid give different oxidation products on reaction with copper metal.

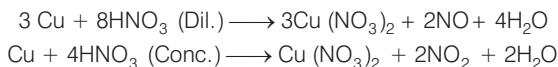

**Q. 57**  $\text{PCl}_5$  reacts with finely divided silver on heating and a white silver salt is obtained, which dissolves on adding excess aqueous  $\text{NH}_3$  solution. Write the reactions involved to explain what happens.

**Ans.**  $\text{PCl}_5$  on reaction with finely divided silver produced silver halide.

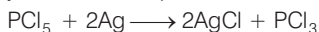

$\text{AgCl}$  on further reaction with aqueous ammonia solution produces a soluble complex of  $[\text{Ag} (\text{NH}_3)_2]^+ \text{Cl}^-$

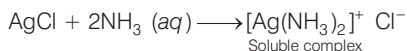

**Q. 58** Phosphorus forms a number of oxoacids. Out of these oxoacids, phosphinic acid has strong reducing property. Write its structure and also write a reaction showing its reducing behaviour.

**Ans.** Among various forms of oxoacids, phosphinic acid has stronger reducing property.

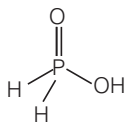

**Structure of phosphinic acid**

Reaction showing reducing behaviour of phosphinic acid is as follows

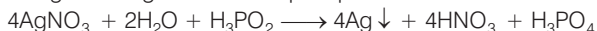

## Matching The Columns

**Q. 59** Match the compounds given in Column I with the hybridisation and shape given in Column II and mark the correct option.

Column I	Column II
A. $\text{XeF}_6$	1. $sp^3d^3$ -distorted octahedral
B. $\text{XeO}_3$	2. $sp^3d^2$ -square planar
C. $\text{XeOF}_4$	3. $sp^3$ -pyramidal
D. $\text{XeF}_4$	4. $sp^3d^2$ -square pyramidal

**Codes**

A	B	C	D	A	B	C	D
(a) 1	3	4	2	(b) 1	2	4	3
(c) 4	3	1	2	(d) 4	1	2	3

Ans. (a) A. →(1) B. →(3) C. →(4) D. →(2)

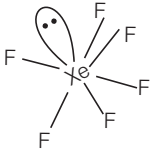
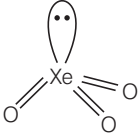
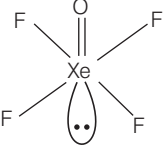
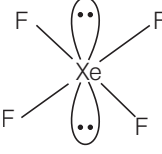
S. No.	Compound	Hybridisation
A.		$sp^3d^3$ -distorted octahedral
B.		$sp^3$ -pyramidal
C.		$sp^3d^2$ -square pyramidal
D.		$sp^3d^2$ -square planar

Q. 60 Match the formulas of oxides given in Column I with the type of oxide given in Column II and mark the correct option.

Column I	Column II
A. $Pb_3O_4$	1. Neutral oxide
B. $N_2O$	2. Acidic oxide
C. $Mn_2O_7$	3. Basic oxide
D. $Bi_2O_3$	4. Mixed oxide

Codes

A	B	C	D	A	B	C	D		
(a)	1	2	3	4	(b)	4	1	2	3
(c)	3	2	4	1	(d)	4	3	1	2

Ans. (b) A. →(4) B. →(1) C. →(2) D. →(3)

	Formulas of the compound	Type of oxide
A.	$Pb_3O_4$ ( $PbO \cdot Pb_2O_3$ )	Mixed oxide
B.	$N_2O$	Neutral oxide
C.	$Mn_2O_7$	Acidic oxide
D.	$Bi_2O_3$	Basic oxide

$Mn_2O_7$  on dissolution in water produces acidic solution.

$Bi_2O_3$  on dissolution in water produces basic solution.

**Q. 61** Match the items of Columns I and II and mark the correct option.

Column I	Column II
A. $\text{H}_2\text{SO}_4$	1. Highest electron gain enthalpy
B. $\text{CCl}_3\text{NO}_2$	2. Chalcogen
C. $\text{Cl}_2$	3. Tear gas
D. Sulphur	4. Storage batteries

**Codes**

A B C D

(a) 4 3 1 2

(c) 4 1 2 3

A B C D

(b) 3 4 1 2

(d) 2 1 3 4

**Ans. (a)** A. →(4) B. →(3) C. →(1) D. →(2)

A.  $\text{H}_2\text{SO}_4$  is used in storage batteries.

B.  $\text{CCl}_3\text{NO}_2$  is known as tear gas.

C.  $\text{Cl}_2$  has highest electron gain enthalpy.

D. Sulphur is a member of chalcogen *i.e.*, ore producing elements.

**Q. 62** Match the species given in Column I with the shape given in Column II and mark the correct option.

Column I	Column II
A. $\text{SF}_4$	1. Tetrahedral
B. $\text{BrF}_3$	2. Pyramidal
C. $\text{BrO}_3^-$	3. Sea-saw shaped
D. $\text{NH}_4^+$	4. Bent T-shaped

**Codes**

A B C D

(a) 3 2 1 4

(c) 1 2 3 4

A B C D

(b) 3 4 2 1

(d) 1 4 3 2

**Ans. (b)** A. →(3) B. →(4) C. →(2) D. →(1)

	Species	Shape	Structure
A.	$\text{SF}_4$	Sea-saw shaped	
B.	$\text{BrF}_3$	Bent T-shaped	
C.	$\text{BrO}_3^-$	Pyramidal	
D.	$\text{NH}_4^+$	Tetrahedral	

**Q. 63** Match the items of Columns I and II and mark the correct option.

Column I	Column II
A. Its partial hydrolysis does not change oxidation state of central atom.	1. He
B. It is used in modern diving apparatus.	2. XeF <sub>6</sub>
C. It is used to provide inert atmosphere for filling electrical bulbs.	3. XeF <sub>4</sub>
D. Its central atom is in $sp^3d^2$ hybridisation.	4. Ar

**Codes**

A	B	C	D	A	B	C	D
(a) 1	4	2	3	(b) 1	2	3	4
(c) 2	1	4	3	(d) 1	3	2	4

**Ans. (c)** A. → (2)    B. → (1)    C. → (4)    D. → (3)

(A) Partial hydrolysis of XeF<sub>6</sub> does not change oxidation state of central atom.

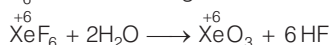

(B) He is used in modern diving apparatus.

(C) Ar is used to provide inert atmosphere for filling electrical bulbs

(D) Central atom (Xe) of XeF<sub>4</sub> is in  $sp^3d^2$  hybridisation.

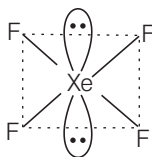

**Square planar geometry**

## Assertion and Reason

*In the following questions a statement of Assertion (A) followed by a statement of Reason (R) is given. Choose the correct answer out of the following choices.*

- Both Assertion and Reason are correct statements, and Reason is the correct explanation of the Assertion.
- Both Assertion and Reason are correct statements, and Reason is not the correct explanation of the Assertion.
- Assertion is correct, but Reason is wrong statement.
- Assertion is wrong but Reason is correct statement.
- Both Assertion and Reason are wrong statements.

**Q. 64** Assertion (A) N<sub>2</sub> is less reactive than P<sub>4</sub>.

Reason (R) Nitrogen has more electron gain enthalpy than phosphorus.

**Ans. (c)** Assertion is true, but reason is false.

$N_2$  is less reactive than  $P_4$  due to high value of bond dissociation energy which is due to presence of triple bond between two N-atoms of  $N_2$  molecule.

**Q. 65** Assertion (A)  $HNO_3$  makes iron passive.

Reason (R)  $HNO_3$  forms a protective layer of ferric nitrate on the surface of iron.

**Ans. (c)** Assertion is true, but reason is false.

$HNO_3$  makes iron passive due to formation of passive form of oxide on the surface. Hence, Fe does not dissolve in conc  $HNO_3$  solution.

**Q. 66** Assertion (A) HI cannot be prepared by the reaction of KI with concentrated  $H_2SO_4$ .

Reason (R) HI has lowest H—X bond strength among halogen acids.

**Ans. (b)** Both assertion and reason are correct statements, but reason is not the correct explanation of the assertion.

HI cannot be prepared by the reaction of KI with concentrated  $H_2SO_4$  because HI is converted into  $I_2$  on reaction with  $H_2SO_4$ .

**Q. 67** Assertion (A) Both rhombic and monoclinic sulphur exist as  $S_8$  but oxygen exists as  $O_2$ .

Reason (R) Oxygen forms  $p\pi - p\pi$  multiple bond due to small size and small bond length but  $p\pi - p\pi$  bonding is not possible in sulphur.

**Ans. (a)** Both assertion and reason are correct statements, and reason is the correct explanation of the assertion.

Both rhombic and monoclinic sulphur exist as  $S_8$  but oxygen exists as  $O_2$ , because oxygen forms  $p\pi - p\pi$  multiple bond due to its small size and small bond length. But  $p\pi - p\pi$  bonding is not possible in sulphur due to its bigger size as compared to oxygen.

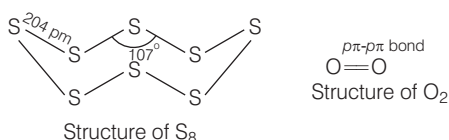

**Q. 68** Assertion (A)  $NaCl$  reacts with concentrated  $H_2SO_4$  to give colourless fumes with pungent smell. But on adding  $MnO_2$  the fumes become greenish yellow.

Reason (R)  $MnO_2$  oxidises  $HCl$  to chlorine gas which is greenish yellow.

**Ans. (a)** Both assertion and reason are correct statements, and reason is the correct explanation of the assertion.

$NaCl$  reacts with concentrated  $H_2SO_4$  to give colourless fumes with pungent smell. Pungent smell is due to formation of  $HCl$ .

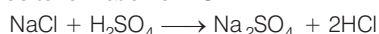

But on adding  $MnO_2$  the fumes become greenish yellow due to formation of chlorine gas.

**Q. 69** Assertion (A)  $\text{SF}_6$  cannot be hydrolysed but  $\text{SF}_4$  can be.

Reason (R) Six F-atoms in  $\text{SF}_6$  prevent the attack of  $\text{H}_2\text{O}$  on sulphur atom of  $\text{SF}_6$ .

**Ans. (a)** Assertion and reason both are true and reason is the correct explanation of assertion.  $\text{SF}_4$  can be hydrolysed but  $\text{SF}_6$  can not because six F-atoms in  $\text{SF}_6$  prevent the attack of  $\text{H}_2\text{O}$  on sulphur atoms of  $\text{SF}_6$ .

## Long Answer Type Questions

**Q. 70** An amorphous solid "A" burns in air to form a gas "B" which turns lime water milky. The gas is also produced as a by-product during roasting of sulphide ore. This gas decolourises acidified aqueous  $\text{KMnO}_4$  solution and reduces  $\text{Fe}^{3+}$  to  $\text{Fe}^{2+}$ . Identify the solid "A" and the gas "B" and write the reactions involved.

### 💡 Thinking Process

*This problem is based on concept of properties of sulphur and its oxide.*

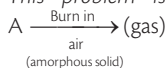

*Amorphous solid A gives B is a gas which turns lime water milky and also produced as a by product during roasting of sulphide ore. This gas decolourises acidified aqueous  $\text{KMnO}_4$  solution and reduces  $\text{Fe}^{3+}$  to  $\text{Fe}^{2+}$ . Hence, compound B (g) must be  $\text{SO}_2$ .*

**Ans.** Since, the by-product of roasting of sulphide ore is  $\text{SO}_2$ , so A is  $\text{S}_8$  'A' =  $\text{S}_8$ ; 'B' =  $\text{SO}_2$

### Reactions

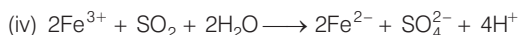
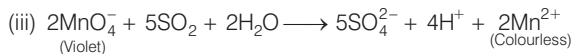
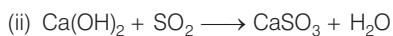
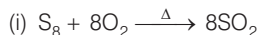

**Q. 71** On heating lead (II) nitrate gives a brown gas "A". The gas "A" on cooling changes to colourless solid "B". Solid "B" on heating with NO changes to a blue solid 'C'. Identify 'A', 'B' and 'C' and also write reactions involved and draw the structures of 'B' and 'C'.

### 💡 Thinking Process

*This problem is based on preparation and properties of  $\text{NO}_2$ .*

**Ans.**  $\text{Pb}(\text{NO}_3)_2$  on heating produces a brown coloured gas which may be  $\text{NO}_2$ . Since, on reaction with  $\text{N}_2\text{O}_4$  and on heating it produces  $\text{N}_2\text{O}_3$  and  $\text{N}_2\text{O}_4$  respectively.

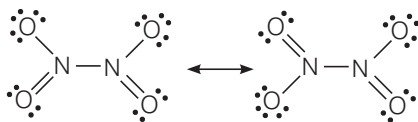
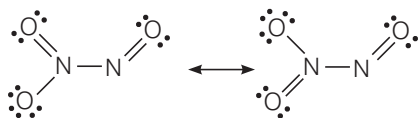
**Structures**(i)  $N_2O_4$ (ii)  $N_2O_3$ 

**Q. 72** On heating compound (A) gives a gas (B) which is a constituent of air. This gas when treated with 3 moles of hydrogen ( $H_2$ ) in the presence of a catalyst gives another gas (C) which is basic in nature. Gas C on further oxidation in moist condition gives a compound (D) which is a part of acid rain. Identify compounds (A) to (D) and also give necessary equations of all the steps involved.

**Ans.** The main constituents of air are nitrogen (78%) and oxygen (21%). Only  $N_2$  reacts with three moles of  $H_2$  in the presence of a catalyst to give  $NH_3$  (ammonia) which is a gas having basic nature. On oxidation,  $NH_3$  gives  $NO_2$  which is a part of acid rain. So, the compounds A to D are as

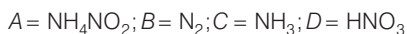

Reactions involved can be given, as

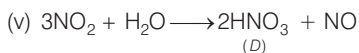
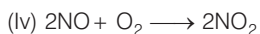
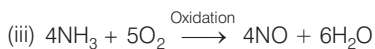
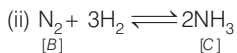
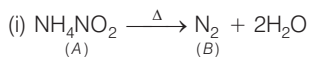

# *d* and *f*-Block Elements

## Multiple Choice Questions (MCQs)

**Q. 1** Electronic configuration of a transition element X in +3 oxidation state is  $[\text{Ar}]3d^5$ . What is its atomic number?

- (a) 25                      (b) 26                      (c) 27                      (d) 24

**Ans. (b)** Electronic configuration of  $X^{3+}$  is  $[\text{Ar}]3d^5$   
It represents the total number of  $e^-$ s and oxidation state.  
Therefore, atomic number of  $X = 18 + 5 + 3 = 26$   
Hence, option (b) is correct.

**Q. 2** The electronic configuration of Cu(II) is  $3d^9$  where as that of Cu(I) is  $3d^{10}$ .  
Which of the following is correct?

- (a) Cu(II) is more stable  
(b) Cu(II) is less stable  
(c) Cu(I) and Cu(II) are equally stable  
(d) Stability of Cu(I) and Cu(II) depends on nature of copper salts

**Ans. (a)** Cu(II) is more stable than Cu(I). As it is known that, Cu(I) has  $3d^{10}$  stable configuration while Cu(II) has  $3d^9$  configuration. But Cu(II) is more stable due to greater effective nuclear charge of Cu(II) *i.e.*, it hold 17 electrons instead of 18 in Cu(I).

**Q. 3** Metallic radii of some transition elements are given below. Which of these elements will have highest density?

Element	Fe	Co	Ni	Cu
Metallic radii/pm	126	125	125	128

- (a) Fe                      (b) Ni                      (c) Co                      (d) Cu

**Ans. (d)** On moving left to right along period, metallic radius decreases while mass increases. Decrease in metallic radius coupled with increase in atomic mass results in increase in density of metal.  
Hence, among the given four choices Cu belongs to right side of Periodic Table in transition metal, and it has highest density ( $89 \text{ g/cm}^3$ ).



**Q. 4** Generally, transition elements form coloured salts due to the presence of unpaired electrons. Which of the following compounds will be coloured in solid state?

- (a)  $\text{Ag}_2\text{SO}_4$                       (b)  $\text{CuF}_2$                       (c)  $\text{ZnF}_2$                       (d)  $\text{Cu}_2\text{Cl}_2$

**Ans. (b)** Transition elements form coloured salt due to the presence of unpaired electrons. In  $\text{CuF}_2$ ,  $\text{Cu(II)}$  contain one unpaired electron hence,  $\text{CuF}_2$  is coloured in solid state.

**Q. 5** On addition of small amount of  $\text{KMnO}_4$  to concentrated  $\text{H}_2\text{SO}_4$ , a green oily compound is obtained which is highly explosive in nature. Identify the compound from the following.

- (a)  $\text{Mn}_2\text{O}_7$                       (b)  $\text{MnO}_2$                       (c)  $\text{MnSO}_4$                       (d)  $\text{Mn}_2\text{O}_3$

**Ans. (a)** On addition of  $\text{KMnO}_4$  to concentrated  $\text{H}_2\text{SO}_4$ , a green oily compound  $\text{Mn}_2\text{O}_7$  is obtained which is highly explosive in nature.



**Q. 6** The magnetic nature of elements depends on the presence of unpaired electrons. Identify the configuration of transition element, which shows highest magnetic moment.

- (a)  $3d^7$                       (b)  $3d^5$                       (c)  $3d^8$                       (d)  $3d^2$

**Thinking Process**

*This problem is based on calculation of magnetic moment can be done as  
Magnetic moment ( $\mu$ ) =  $\sqrt{n(n+2)}$  BM.*

**Ans. (b)** Greater the number of unpaired electron, higher will be its value of magnetic moment. Since,  $3d^5$  has 5 unpaired electrons hence highest magnetic moment.

$$\begin{aligned}\mu &= \sqrt{5(5+2)} \\ &= \sqrt{35} \\ &= 5.95\text{BM}\end{aligned}$$

**Q. 7** Which of the following oxidation state is common for all lanthanoids?

- (a) +2                      (b) +3                      (c) +4                      (d) +5

**Ans. (b)** Lanthanoids show common oxidation state of +3. Some of which also show +2 and +4 stable oxidation state alongwith +3 oxidation state. These are shown by those elements which by losing 2 or 4 electrons acquire a stable configuration of  $f^0$ ,  $f^7$  or  $f^{14}$ , e.g.,  $\text{Eu}^{2+}$  is  $[\text{Xe}]4f^7$ ,  $\text{Yb}^{2+}$  is  $[\text{Xe}]4f^{14}$ ,  $\text{Ce}^{4+}$  is  $[\text{Xe}]4f^0$  and  $\text{Tb}^{4+}$  is  $[\text{Xe}]4f^7$ .

**Q. 8** Which of the following reactions are disproportionation reactions?

- (i)  $\text{Cu}^+ \longrightarrow \text{Cu}^{2+} + \text{Cu}$   
 (ii)  $3\text{MnO}_4^- + 4\text{H}^+ \longrightarrow 2\text{MnO}_4^- + \text{MnO}_2 + 2\text{H}_2\text{O}$   
 (iii)  $2\text{KMnO}_4 \longrightarrow \text{K}_2\text{MnO}_4 + \text{MnO}_2 + \text{O}_2$   
 (iv)  $2\text{MnO}_4^- + 3\text{Mn}^{2+} + 2\text{H}_2\text{O} \longrightarrow 5\text{MnO}_2 + 4\text{H}^+$

- (a) (i)                      (b) (i), (ii) and (iii)                      (c) (ii), (iii) and (iv)                      (d) (i) and (iv)

**Ans. (a)** The reaction in which oxidation as well as reduction, occur upon same atom simultaneously is known as disproportionation reaction.

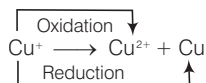

**Q. 9** When  $\text{KMnO}_4$  solution is added to oxalic acid solution, the decolourisation is slow in the beginning but becomes instantaneous after some time because

- (a)  $\text{CO}_2$  is formed as the product (b) reaction is exothermic  
(c)  $\text{MnO}_4^-$  catalyses the reaction (d)  $\text{Mn}^{2+}$  acts as autocatalyst

**Ans. (d)** When  $\text{KMnO}_4$  solution is added to oxalic acid solution, the decolourisation is slow in the beginning but becomes instantaneous after some time because  $\text{Mn}^{2+}$  acts as autocatalyst.

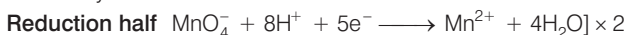

**Overall equation**



**End point of this reaction** Colourless to light pink

**Q. 10** There are 14 elements in actinoid series. Which of the following elements does not belong to this series?

- (a) U (b) Np (c) Tm (d) Fm

**Ans. (c)** Tm ( $Z = 69$ ) do not belong to actinoid series. The actinoid series is with atomic numbers 90 to 103. Thulium (Tm) has atomic number 69 belongs to lanthanoids (4f series).

**Q. 11**  $\text{KMnO}_4$  acts as an oxidising agent in acidic medium. The number of moles of  $\text{KMnO}_4$  that will be needed to react with one mole of sulphide ions in acidic solution is

- (a)  $\frac{2}{5}$  (b)  $\frac{3}{5}$  (c)  $\frac{4}{5}$  (d)  $\frac{1}{5}$

**Ans.** The reaction of  $\text{KMnO}_4$  in which it acts as an oxidising agent in acidic medium is

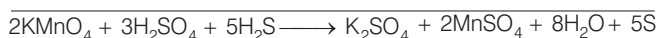
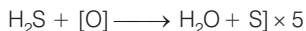
$$2\text{KMnO}_4 + 3\text{H}_2\text{SO}_4 \longrightarrow \text{K}_2\text{SO}_4 + 2\text{MnSO}_4 + 3\text{H}_2\text{O} + 5[\text{O}]$$

5 moles of  $\text{S}^{2-}$  ions react with 2 moles of  $\text{KMnO}_4$ . So, 1 mole of  $\text{S}^{2-}$  ion will react with  $\frac{2}{5}$  moles of  $\text{KMnO}_4$ .

**Q. 12** Which of the following is amphoteric oxide?

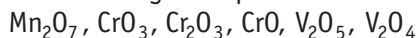

- (a)  $\text{V}_2\text{O}_5, \text{Cr}_2\text{O}_3$  (b)  $\text{Mn}_2\text{O}_7, \text{CrO}_3$   
(c)  $\text{CrO}, \text{V}_2\text{O}_5$  (d)  $\text{V}_2\text{O}_5, \text{V}_2\text{O}_4$

**Ans. (a)**  $\text{V}_2\text{O}_5$  and  $\text{Cr}_2\text{O}_3$  are amphoteric oxide because both react with alkalis as well as acids.

**Note** In lower oxides, the basic character is predominant while in higher oxides, the acidic character is predominant.

**Q. 13** Gadolinium belongs to 4f series. Its atomic number is 64. Which of the following is the correct electronic configuration of gadolinium?

- (a)  $[\text{Xe}]4f^75d^16s^2$  (b)  $[\text{Xe}]4f^65d^26s^2$   
 (c)  $[\text{Xe}]4f^86d^2$  (d)  $[\text{Xe}]4f^95s^1$

**Ans. (a)** Gadolinium belongs to 4f series and has atomic number 64. The correct electronic configuration of gadolinium is



It has extra stability due to half-filled 4f subshell.

**Q. 14** Interstitial compounds are formed when small atoms are trapped inside the crystal lattice of metals. Which of the following is not the characteristic property of interstitial compounds?

- (a) They have high melting points in comparison to pure metals  
 (b) They are very hard  
 (c) They retain metallic conductivity  
 (d) They are chemically very reactive

**Ans. (d)** Interstitial compounds are formed when small atoms are trapped inside the crystal lattice of metals. *Some of their important characteristics are as follows*

- (i) They are very hard and rigid.  
 (ii) They have high melting point which are higher than those of the pure metals.  
 (iii) They show conductivity like that of the pure metal.  
 (iv) They acquire chemical inertness.

**Q. 15** The magnetic moment is associated with its spin angular momentum and orbital angular momentum. Spin only magnetic moment value of  $\text{Cr}^{3+}$  ion is

- (a) 2.87 BM (b) 3.87 BM  
 (c) 3.47 BM (d) 3.57 BM

**Ans. (b)** The magnetic moment is associated with its spin angular momentum and orbital angular momentum.

Spin only magnetic moment value of  $\text{Cr}^{3+}$  ion is  $3d^3$

$$\begin{aligned} \text{Hence, magnetic moment } (\mu) &= \sqrt{n(n+2)} \text{ BM} \\ &= \sqrt{3(3+2)} = \sqrt{15} \\ &= 3.87 \text{ BM} \end{aligned}$$

**Q. 16**  $\text{KMnO}_4$  acts as an oxidising agent in alkaline medium. When alkaline  $\text{KMnO}_4$  is treated with KI, iodide ion is oxidised to .....

- (a)  $\text{I}_2$  (b)  $\text{IO}^-$   
 (c)  $\text{IO}_3^-$  (d)  $\text{IO}_4^-$

**Ans. (c)**  $\text{KMnO}_4$  acts as an oxidising agent in alkaline medium. When alkaline  $\text{KMnO}_4$  is treated with KI, iodide ion is oxidised to  $\text{IO}_3^-$ .



**Q. 17** Which of the following statements is not correct?

- (a) Copper liberates hydrogen from acids
- (b) In its higher oxidation states, manganese forms stable compounds with oxygen and fluorine
- (c)  $\text{Mn}^{3+}$  and  $\text{Co}^{3+}$  are oxidising agents in aqueous solution
- (d)  $\text{Ti}^{2+}$  and  $\text{Cr}^{2+}$  are reducing agents in aqueous solution

**Ans. (a)** Copper lies below hydrogen in the electrochemical series and hence does not liberate  $\text{H}_2$  from acids. Therefore, option (a) is not correct.  
Other three options (b, c, d) are correct.

**Q. 18** When acidified  $\text{K}_2\text{Cr}_2\text{O}_7$  solution is added to  $\text{Sn}^{2+}$  salt then  $\text{Sn}^{2+}$  changes to

- (a) Sn
- (b)  $\text{Sn}^{3+}$
- (c)  $\text{Sn}^{4+}$
- (d)  $\text{Sn}^+$

**Ans. (c)** When acidified  $\text{K}_2\text{Cr}_2\text{O}_7$  solution is added to  $\text{Sn}^{2+}$  salts then  $\text{Sn}^{2+}$  changes to  $\text{Sn}^{4+}$ .  
The reaction is given below

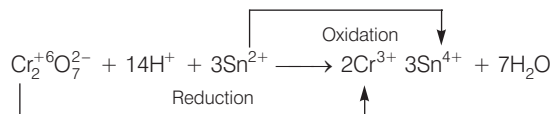

**Q. 19** Highest oxidation state of manganese in fluoride is +4 ( $\text{MnF}_4$ ) but highest oxidation state in oxides is +7 ( $\text{Mn}_2\text{O}_7$ ) because

- (a) fluorine is more electronegative than oxygen
- (b) fluorine does not possess *d* orbitals
- (c) fluorine stabilises lower oxidation state
- (d) in covalent compounds, fluorine can form single bond only while oxygen forms double bond

**Ans. (d)** Highest oxidation state of manganese in fluoride is +4 ( $\text{MnF}_4$ ) but highest oxidation state in oxides is +7 ( $\text{Mn}_2\text{O}_7$ ). The reason is that in covalent compounds fluorine can form single bond while oxygen forms double bond.

**Q. 20** Although zirconium belongs to 4d transition series and hafnium to 5d transition series even then they show similar physical and chemical properties because .....

- (a) both belong to *d*-block
- (b) both have same number of electrons
- (c) both have similar atomic radius
- (d) both belong to the same group of the Periodic Table

**Ans. (c)** Due to lanthanoid contraction, Zr and Hf possess nearly same atomic and ionic radii i.e., Zr = 160 pm and Hf = 159 pm,  $\text{Zr}^{4+}$  = 79 pm and  $\text{Hf}^{4+}$  = 78 pm. Therefore, these two elements show similar properties (physical and chemical properties).

**Q. 21** Why is HCl not used to make the medium acidic in oxidation reactions of  $\text{KMnO}_4$  in acidic medium?

- (a) Both HCl and  $\text{KMnO}_4$  act as oxidising agents
- (b)  $\text{KMnO}_4$  oxidises HCl into  $\text{Cl}_2$  which is also an oxidising agent
- (c)  $\text{KMnO}_4$  is a weaker oxidising agent than HCl
- (d)  $\text{KMnO}_4$  acts as a reducing agent in the presence of HCl

**Ans. (b)** HCl is not used to make the medium acidic in oxidation reactions of  $\text{KMnO}_4$  in acidic medium. The reason is that if HCl is used, the oxygen produced from  $\text{KMnO}_4 + \text{HCl}$  is partly utilised in oxidising HCl to  $\text{Cl}_2$ , which itself acts as an oxidising agent and partly oxidises the reducing agent.

## Multiple Choice Questions (More Than One Options)

**Q. 22** Generally transition elements and their salts are coloured due to the presence of unpaired electrons in metal ions. Which of the following compounds are coloured?

- (a)  $\text{KMnO}_4$
- (b)  $\text{Ce}(\text{SO}_4)_2$
- (c)  $\text{TiCl}_4$
- (d)  $\text{Cu}_2\text{Cl}_2$

**Ans. (a, b)**

$\text{KMnO}_4$  is coloured due to the charge transfer and not because of the presence of unpaired electrons. Similarly, oxidation state of Ce in  $\text{Ce}(\text{SO}_4)_2$  is +4 with  $4f^0$  electronic configuration. It is also coloured (yellow) due to charge transfer and not due to  $f-f$  transition.

**Q. 23** Transition elements show magnetic moment due to spin and orbital motion of electrons. Which of the following metallic ions have almost same spin only magnetic moment?

- (a)  $\text{Co}^{2+}$
- (b)  $\text{Cr}^{2+}$
- (c)  $\text{Mn}^{2+}$
- (d)  $\text{Cr}^{3+}$

**Ans. (a, d)**

Electronic configuration of  $\text{Co}^{2+} = [\text{Ar}] 3d^7$ ; Number of unpaired electrons = 3

Electronic configuration of  $\text{Cr}^{2+} = [\text{Ar}] 3d^4$ ; Number of unpaired electrons = 4

Electronic configuration of  $\text{Mn}^{2+} = [\text{Ar}] 3d^5$ ; Number of unpaired electrons = 5

Electronic configuration of  $\text{Cr}^{3+} = [\text{Ar}] 3d^3$ ; Number of unpaired electrons = 3

Hence, it is clearly seen that both  $\text{Co}^{2+}$  and  $\text{Cr}^{3+}$  have same number of unpaired electrons. *i.e.*, 3.

**Q. 24** In the form of dichromate, Cr(VI) is a strong oxidising agent in acidic medium but Mo(VI) in  $\text{MoO}_3$  and W(VI) in  $\text{WO}_3$  are not because

- (a) Cr (VI) is more stable than Mo(VI) and W(VI).
- (b) Mo (VI) and W (VI) are more stable than Cr(VI).
- (c) Higher oxidation states of heavier members of group-6 of transition series are more stable.
- (d) Lower oxidation states of heavier members of group-6 of transition series are more stable.

**Ans. (b, c)**

In d-block elements, for heavier elements, the higher oxidation states are more stable. Hence, Mo(VI) and W(VI) are more stable than Cr (VI). That's why, Cr (VI) in the form of dichromate is a stronger oxidising agent in acidic medium whereas  $\text{MoO}_3$  and  $\text{WO}_3$  are not.

**Q. 25** Which of the following actinoids show oxidation states upto +7?

- (a) Am                      (b) Pu                      (c) U                      (d) Np

**Ans. (b, d)**

The oxidation states of the following actinoids are

- (a) Americium ( $Z = 95$ ); Electronic configuration =  $[\text{Rn}]5f^7 6d^0 7s^2$   
Oxidation states shown by Am = + 3, + 4, + 5, + 6.
- (b) Plutonium ( $Z = 94$ ); Electronic configuration =  $[\text{Rn}] 5f^6 6d^0 7s^2$   
Oxidation states shown by Pu = + 3, + 4, + 5, + 6, + 7.
- (c) Uranium ( $Z = 92$ ); Electronic configuration =  $[\text{Rn}] 5f^3 6d^1 7s^2$   
Oxidation states shown by U = + 3, + 4, + 5, + 6.
- (d) Neptunium ( $Z = 93$ ); Electronic configuration =  $[\text{Rn}] 5f^4 6d^1 7s^2$   
Oxidation states shown by Np = + 3, + 4, + 5, + 6, + 7.

**Q. 26** General electronic configuration of actinoids is  $(n-2)f^{1-14} (n-1)d^{0-2} ns^2$ .

Which of the following actinoids have one electron in 6d orbital?

- (a) U (Atomic number. 92)                      (b) Np (Atomic number. 93)  
(c) Pu (Atomic number. 94)                      (d) Am (Atomic number. 95)

**Ans. (a, b)**

General electronic configuration of actinoids is  $(n-1)f^{1-14} (n-1)d^{0-2} ns^2$ . U and Np each have one electron in 6d orbital. (Also, refer to Q. 25)

**Q. 27** Which of the following lanthanoids show +2 oxidation state besides the characteristic oxidation state +3 of lanthanoids?

- (a) Ce                      (b) Eu                      (c) Yb                      (d) Ho

**Ans. (b, c)**

- (a) Cerium ( $Z = 57$ )  $\Rightarrow$  Electronic configuration =  $[\text{Xe}]4f^5 5d^0 6s^2$   
Oxidation state of Ce = +3, +4
- (b) Europium ( $Z = 63$ )  $\Rightarrow$  Electronic configuration =  $[\text{Xe}]4f^7 5d^0 6s^2$   
Oxidation state of Eu = +2, +3
- (c) Ytterbium ( $Z = 70$ )  $\Rightarrow$  Electronic configuration =  $[\text{Xe}]4f^{14} 5d^0 6s^2$   
Oxidation state of Yb = +2, +3
- (d) Holmium ( $Z = 67$ )  $\Rightarrow$  Electronic configuration =  $[\text{Xe}]4f^{11} 5d^0 6s^2$   
Oxidation state of Ho = +3

**Q. 28** Which of the following ions show higher spin only magnetic moment value?

- (a)  $\text{Ti}^{3+}$                       (b)  $\text{Mn}^{2+}$   
(c)  $\text{Fe}^{2+}$                       (d)  $\text{Co}^{3+}$

**Ans. (b, c)**

As,

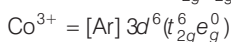
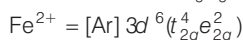
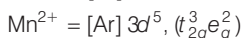
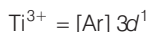

Crystal field splitting energy (CFSE) is high in  $\text{Co}^{3+}$ , thus electrons pair up in  $t_{2g}$ . Hence, only  $\text{Fe}^{2+}$  and  $\text{Mn}^{2+}$  show higher spin magnetic moment value.

**Q. 29** Transition elements form binary compounds with halogens. Which of the following elements will form  $\text{MF}_3$  type compounds?

(a) Cr

(b) Co

(c) Cu

(d) Ni

**Ans. (a, b)**

Transition elements such as Cr and Co form binary compounds with halogens, *i.e.*,  $\text{CrF}_3$  and  $\text{CoF}_3$  whereas Cu and Ni do not form  $\text{CuF}_3$  and  $\text{NiF}_3$ .

**Q. 30** Which of the following will not act as oxidising agents?

(a)  $\text{CrO}_3$ (b)  $\text{MoO}_3$ (c)  $\text{WO}_3$ (d)  $\text{CrO}_4^{2-}$ **Ans. (b, c)**

A species can act as oxidising agent only when metal is present in high oxidation state but lower oxidation state show stability. As higher oxidations states of W and Mo are more stable, therefore they will not act as oxidising agents.

**Q. 31** Although +3 is the characteristic oxidation state for lanthanoids but cerium also shows +4 oxidation state because

(a) it has variable ionisation enthalpy

(b) it has a tendency to attain noble gas configuration

(c) it has a tendency to attain  $f^0$  configuration(d) it resembles  $\text{Pb}^{4+}$ **Ans. (b, c)**

Electronic configuration of  ${}_{58}\text{Ce} = {}_{54}[\text{Xe}] 4f^2 5d^0 6s^2$ .

Therefore, electronic configuration of  $\text{Ce}^{4+} = {}_{54}[\text{Xe}] 4f^0$ .

Thus, it has a tendency to attain noble gas configuration and attain  $f^0$  configuration.

## Short Answer Type Questions

**Q. 32** Why does copper not replace hydrogen from acids?

**Ans.** Copper not replace hydrogen from acids because Cu has positive  $E^\circ$  value, i.e., less reactive than hydrogen which has electrode potential 0.00V.

**Q. 33** Why  $E^-$  values for Mn, Ni and Zn are more negative than expected?

**Ans.** Negative values of  $Mn^{2+}$  and  $Zn^{2+}$  are related to stabilities of half-filled and completely filled configuration respectively. But for  $Ni^{2+}$ ,  $E^\circ$  value is related to the highest negative enthalpy of hydration.

Hence,  $E^S$  values for Mn, Ni and Zn are more negative than expected.

**Q. 34** Why first ionisation enthalpy of Cr is lower than that of Zn?

**Ans.** Ionisation enthalpy of Cr is less than that of Zn because Cr has stable  $d^5$  configuration. In case of zinc, electron comes out from completely filled 4s-orbital. So, removal of electron from zinc requires more energy as compared to the chromium.

**Q. 35** Transition elements show high melting points. Why?

**Ans.** Transition elements show high melting point, due to involvement of greater number of electrons in the interatomic bonding from  $(n-1)d$ -orbitals in addition to  $ns$  electrons in forming metallic bond. Thus, large number of electrons participate forming large number of metallic bond.

**Q. 36** When  $Cu^{2+}$  ion is treated with KI, a white precipitate is formed. Explain the reaction with the help of chemical equation.

**Ans.** When  $Cu^{2+}$  ion is treated with KI, it produces  $Cu_2I_2$  white precipitate in the final product.

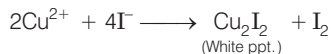

(In this reaction,  $CuI_2$  is formed which being unstable, dissociates into  $Cu_2I_2$  and  $I_2$ ).

**Q. 37** Out of  $Cu_2Cl_2$  and  $CuCl_2$ , which is more stable and why?

**Ans.** Among  $Cu_2Cl_2$  and  $CuCl_2$ ,  $Cu_2Cl_2$  is more stable. Stability of complex can be explained on the basis of stability of oxidation state of copper. Stability of  $Cu^{2+}(aq)$  rather than  $Cu^+(aq)$  is due to much more negative value of  $[\Delta_{hyd}H^S \text{ of } Cu^{2+}(aq)]$  than  $Cu^+$  which more than compensates for the second ionisation enthalpy of Cu.

**Q. 38** When a brown compound of manganese (A) is treated with HCl it gives a gas (B). The gas taken in excess, reacts with  $NH_3$  to give an explosive compound (C). Identify compounds A, B and C.

### 💡 Thinking Process

*This problem is based on the properties of  $MnO_2$  and preparation of  $NCl_3$ .*

**Ans.**  $MnO_2$  is the brown compound of Mn which reacts with HCl to give  $Cl_2$  gas. This gas forms an explosive compound  $NCl_3$  when treated with  $NH_3$ . Thus,  $A = MnO_2$ ;  $B = Cl_2$ ;  $C = NCl_3$  and reactions are as follows

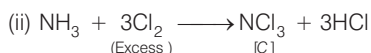
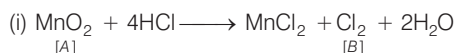







**Q. 50** While filling up of electrons in the atomic orbitals, the 4s orbital is filled before the 3d orbital but reverse happens during the ionisation of the atom. Explain why?

**Ans.** During filling up of electrons follow  $(n + l)$  rule. Here 4s has lower energy than 3d orbital. After the orbitals are filled 4s goes beyond 3d, i.e., 4s is farther from nucleus than 3d. So, electron from 4s is removed earlier than from 3d.

**Q. 51** Reactivity of transition elements decreases almost regularly from Se to Cu. Explain.

**Ans.** Reactivity of transition elements depends mostly upon their ionisation enthalpies. As we move from left to right in the periodic table (Se to Cu), ionisation enthalpies increase almost regularly.

Hence, their reactivity decreases almost regularly from Se to Cu.

## Matching The Columns

**Q. 52** Match the catalysts given in Column I with the processes given in Column II.

Column I (Catalyst)	Column II (Process)
A. Ni in the presence of hydrogen	1. Ziegler-Natta catalyst
B. $\text{Cu}_2\text{Cl}_2$	2. Contact process
C. $\text{V}_2\text{O}_5$	3. Vegetable oil to ghee
D. Finely divided iron	4. Sandmeyer reaction
E. $\text{TiCl}_4 + \text{Al}(\text{CH}_3)_3$	5. Haber's process
	6. Decomposition of $\text{KClO}_3$

**Ans.** A. → (3)    B. → (4)    C. → (2)    D. → (5)    E. → (1)

Catalyst	Process
A. Ni in the presence of hydrogen	Vegetable oil to ghee
B. $\text{Cu}_2\text{Cl}_2$	Sandmeyer reaction
C. $\text{V}_2\text{O}_5$	Contact process $\text{SO}_2 \xrightarrow{\text{V}_2\text{O}_5} \text{SO}_3$
D. Finely divided iron	Haber's process $\text{N}_2 + 3\text{H}_2 \xrightarrow{\text{Fe}} 2\text{NH}_3$
E. $\text{TiCl}_4 + \text{Al}(\text{CH}_3)_3$	Ziegler-Natta catalyst

**Q. 53** Match the compounds/elements given in Column I with uses given in Column II.

Column I (Compound/element)	Column II (Use)
A. Lanthanoid oxide	1. Production of iron alloy
B. Lanthanoid	2. Television screen
C. Misch metall	3. Petroleum cracking
D. Magnesium based alloy is constituent of	4. Lanthanoid metal + iron
E. Mixed oxides of lanthanoids are employed	5. Bullets
	6. X-ray screen

**Ans.** A. → (2)    B. → (1)    C. → (4)    D. → (5)    E. → (3)

	Compound /Element	Use
A.	Lanthanoid oxide	Television screen
B.	Lanthanoid	Production of iron alloy
C.	Misch metall	Lanthanoid metal + iron
D.	Magnesium based alloy is constitute of	Bullets
E.	Mixed oxides of lanthanoids are employed	Petroleum cracking

**Q. 54** Match the properties given in Column I with the metals given in Column II.

Column I (Property)	Column II (Metal)
A. An element which can show +8 oxidation state	1. Mn
B. 3d block element that can show upto +7 oxidation state	2. Cr
C. 3d block element with highest melting point	3. Os
	4. Fe

**Ans.** A. → (3)    B. → (1)    C. → (2)

- A. Osmium is an element which can show +8 oxidation state.  
 B. 3d block element that can show upto +7 oxidation state is manganese.  
 C. 3d block element with highest melting point is chromium.

**Q. 55** Match the statements given in Column I with the oxidation states given in Column II.

Column I	Column II
A. Oxidation state of Mn in $\text{MnO}_2$ is	1. +2
B. Most stable oxidation state of Mn is	2. +3
C. Most stable oxidation state of Mn in oxides is	3. +4
D. Characteristic oxidation state of lanthanoids is	4. +5
	5. +7

**Ans. A.** → (3)    **B.** → (1)    **C.** → (5)    **D.** → (2)

- A. Oxidation state of Mn in  $\text{MnO}_2$  is + 4.  
 B. Most stable oxidation state of Mn is + 2.  
 C. Most stable oxidation state of Mn in oxides is + 7.  
 D. Characteristic oxidation state of lanthanoids is + 3.

**Q. 56** Match the solutions given in Column I and the colours given in Column II.

Column I (Aqueous solution of salt)		Column II (Colour)	
A.	$\text{FeSO}_4 \cdot 7\text{H}_2\text{O}$	1.	Green
B.	$\text{NiCl}_2 \cdot 4\text{H}_2\text{O}$	2.	Light pink
C.	$\text{MnCl}_2 \cdot 4\text{H}_2\text{O}$	3.	Blue
D.	$\text{CoCl}_2 \cdot 6\text{H}_2\text{O}$	4.	Pale green
E.	$\text{Cu}_2\text{Cl}_2$	5.	Pink
		6.	Colourless

**Ans. A.** → (4)    **B.** → (1)    **C.** → (2)    **D.** → (5)    **E.** → (6)

	Aqueous solution of salt	Colour
A.	$\text{FeSO}_4 \cdot 7\text{H}_2\text{O}$	Pale green
B.	$\text{NiCl}_2 \cdot 4\text{H}_2\text{O}$	Green
C.	$\text{MnCl}_2 \cdot 4\text{H}_2\text{O}$	Light pink
D.	$\text{CoCl}_2 \cdot 6\text{H}_2\text{O}$	Pink
E.	$\text{Cu}_2\text{Cl}_2$	Colourless

**Q. 57** Match the property given in Column I with the element given in Column II.

Column I (Property)		Column II (Element)	
A.	Lanthanoid which shows + 4 oxidation state	1.	Pm
B.	Lanthanoid which can show +2 oxidation state	2.	Ce
C.	Radioactive lanthanoid	3.	Lu
D.	Lanthanoid which has $4f^7$ electronic configuration in +3 oxidation state	4.	Eu
E.	Lanthanoid which has $4f^{14}$ electronic configuration in +3 oxidation state	5.	Gd
		6.	Dy

**Ans. A.** → (2)    **B.** → (4)    **C.** → (1)    **D.** → (5)    **E.** → (3)

- A. Lanthanoid which shows +4 oxidation state is cerium.  
 ${}_{58}\text{Ce} = [\text{Xe}]4f^2 5d^0 6s^2$ ; Oxidation state = +3, +4  
 B. Lanthanoid which can show +2 oxidation state is europium.  
 ${}_{63}\text{Eu} = [\text{Xe}]4f^7 5d^0 6s^2$ ; Oxidation state = +2, +3

- C. Radioactive lanthanoid is promethium. It is the only synthetic (man-made) radioactive lanthanoid.
- D. Lanthanoid which has  $4f^7$  electronic configuration in +3 oxidation state is gadolinium.  
 ${}_{64}\text{Gd} = [\text{Xe}]4f^7 5d^1 6s^2$ ; Oxidation state = +3
- E. Lanthanoid which has  $4f^{14}$  electronic configuration in +3 oxidation state is lutetium  
 ${}_{71}\text{Lu} = [\text{Xe}]4f^{14} 5d^1 6s^2$ ; Oxidation state = +3

**Q. 58** Match the properties given in Column I with the metals given in Column II.

Column I (Property)	Column II (Metal)
A. Element with highest second ionisation enthalpy	1. Co
B. Element with highest third ionisation enthalpy	2. Cr
C. M in $\text{M}(\text{CO})_6$ is	3. Cu
D. Element with highest heat of atomisation	4. Zn
	5. Ni

**Ans.** A.  $\rightarrow$  (3)    B.  $\rightarrow$  (4)    C.  $\rightarrow$  (2)    D.  $\rightarrow$  (1)

- A.  $\text{Cu}^+ = 3d^{10}$  which is very stable configuration due to full-filled orbitals. Hence, removal of second electron requires very high energy.
- B.  $\text{Zn}^{2+} = 3d^{10}$  which is very stable configuration. Hence, removal of third electron requires very high energy.
- C. Metal carbonyl with formula  $\text{M}(\text{CO})_6$  is  $\text{Cr}(\text{CO})_6$ .
- D. Nickel is the element with highest heat of atomisation.

## Assertion and Reason

*In the following questions a statement of assertion (A) followed by a statement of reason (R) is given. Choose the correct answer out of the following choices.*

- (a) Both assertion and reason are true, and reason is the correct explanation of the assertion.
- (b) Both assertion and reason are true but reason is not the correct explanation of assertion.
- (c) Assertion is not true but reason is true.
- (d) Both assertion and reason are false.

**Q. 59** Assertion (A)  $\text{Cu}^{2+}$  iodide is not known.  
Reason (R)  $\text{Cu}^{2+}$  oxidises  $\text{I}^-$  to iodine.

**Ans. (a)** Assertion and reason both are correct and reason is the correct explanation of assertion.

Copper (II) iodide ( $\text{CuI}_2$ ) is not known because  $\text{Cu}^{2+}$  oxidises  $\text{I}^-$  to iodine.

**Q. 60** Assertion (A) Separation of Zr and Hf is difficult.

Reason (R) Because Zr and Hf lie in the same group of the Periodic Table.

**Ans. (b)** Assertion and reason are true but reason is not correct explanation of assertion.  
Separation of Zr and Hf is difficult; it is not because of they lie in the same group of Periodic Table. This is due to lanthanoid contraction which causes almost similar radii of both of them.

**Q. 61** Assertion (A) Actinoids form relatively less stable complexes as compared to lanthanoids.

Reason (R) Actinoids can utilise their 5f orbitals alongwith 6d orbitals in bonding but lanthanoids do not use their 4f orbital for bonding.

**Ans. (c)** Assertion is not true but reason is true.  
Actinoids form relatively more stable complexes as compared to lanthanoids because of actinoids can utilise their 5f orbitals along with 6d orbitals in bonding but lanthanoids do not use their 4f orbitals for bonding.

**Q. 62** Assertion (A) Cu cannot liberate hydrogen from acids.

Reason (R) Because it has positive electrode potential.

**Ans. (a)** Assertion and reason both are correct and reason is correct explanation of assertion.  
Cu can not liberate hydrogen from acids because it has positive electrode potential. Metals having negative value of electrode potential liberate H<sub>2</sub> gas.

**Q. 63** Assertion (A) The highest oxidation state of osmium is +8 .

Reason (R) Osmium is a 5d-block element.

**Ans. (b)** Assertion and reason both are correct but reason is not the correct explanation of assertion.  
The highest oxidation state of osmium is +8 due to its ability to expand their octet by using its all 8 electrons (2 from 6s and 6 from 5d).

## Long Answer Type Questions

**Q. 64** Identify A to E and also explain the reaction involved.

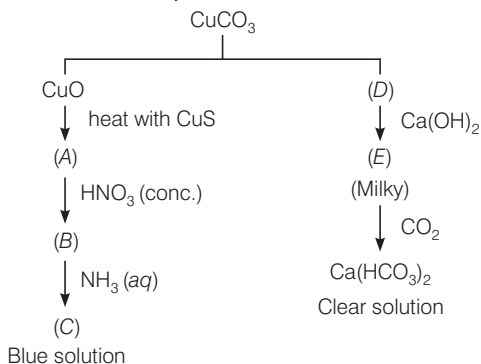

**Ans.** The substances from A to E are

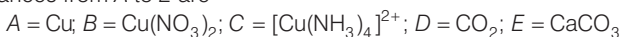

**Reactions:**

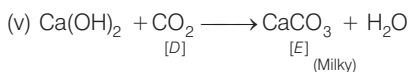
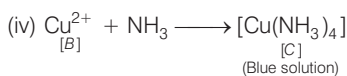
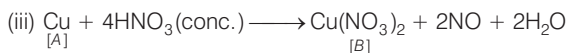
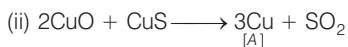
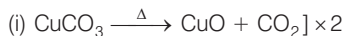

**Q. 65** When a chromite ore (A) is fused with sodium carbonate in free excess of air and the product is dissolved in water, a yellow solution of compound (B) is obtained. After treatment of this yellow solution with sulphuric acid, compound (C) can be crystallised from the solution. When compound (C) is treated with KCl, orange crystals of compound (D) crystallise out. Identify A to D and also explain the reactions.

**Ans.**  $\text{K}_2\text{Cr}_2\text{O}_7$  is an orange compound. It is formed when  $\text{Na}_2\text{Cr}_2\text{O}_7$  reacts with KCl. In acidic medium, yellow coloured  $\text{CrO}_4^{2-}$  (chromate ion) changes into dichromate.

The given process is the preparation method of potassium dichromate from chromite ore.

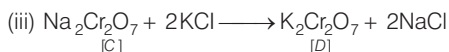
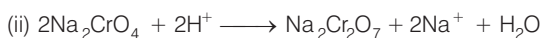
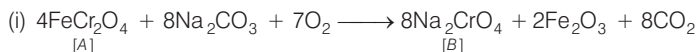
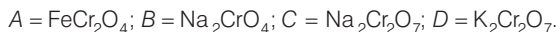



**Q. 66** When an oxide of manganese (A) is fused with KOH in the presence of an oxidising agent and dissolved in water, it gives a dark green solution of compound (B). Compound (B) disproportionates in neutral or acidic solution to give purple compound (C). An alkaline solution of compound (C) oxidises potassium iodide solution to a compound (D) and compound (A) is also formed. Identify compounds A to D and also explain the reactions involved.

**Thinking Process**

*This problem based on the concept of preparation and properties of potassium permanganate.*

**Ans.** It is the method of preparation of potassium permanganate (purple).

Thus, (A) =  $\text{MnO}_2$  (B) =  $\text{K}_2\text{MnO}_4$   
(C) =  $\text{KMnO}_4$  (D) =  $\text{KIO}_3$

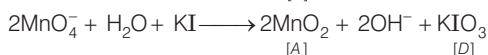
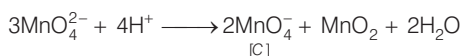
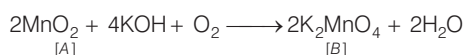

**Q. 67** On the basis of lanthanoid contraction, explain the following:

- (i) Nature of bonding in  $\text{La}_2\text{O}_3$  and  $\text{Lu}_2\text{O}_3$ .
- (ii) Trends in the stability of oxo salts of lanthanoids from La to Lu.
- (iii) Stability of the complexes of lanthanoids.
- (iv) Radii of 4d and 5d block elements.
- (v) Trends in acidic character of lanthanoid oxides.

**Ans.** (i) As the size decreases covalent character increases. Therefore,  $\text{La}_2\text{O}_3$  is more ionic and  $\text{Lu}_2\text{O}_3$  is more covalent.

(ii) As the size decreases from La to Lu, stability of oxo salts also decreases.

(iii) Stability of complexes increases as the size of lanthanoids decreases.

(iv) Radii of 4d and 5d-block elements will be almost same.

(v) Acidic character of oxides increases from La to Lu.

**Q. 68** (a) Answer the following questions

- (i) Which element of the first transition series has highest second ionisation enthalpy?
- (ii) Which element of the first transition series has highest third ionisation enthalpy?
- (iii) Which element of the first transition series has lowest enthalpy of atomisation?

(b) Identify the metal and justify your answer.

(i) Carbonyl  $\text{M}(\text{CO})_5$

(ii)  $\text{MO}_3\text{F}$

- Ans. (a)**
- (i) Cu, because the electronic configuration of Cu is  $3d^{10}4s^1$ . So, second electron needs to be removed from completely filled *d*-orbital which is very difficult.
  - (ii) Zinc, because of electronic configuration of Zn =  $3d^{10}4s^2$  and  $Zn^{2+} = 3d^{10}$  which is fully filled and hence is very stable. Removal of third electron requires very high energy.
  - (iii) Zinc, because of it has completely filled  $3d$  subshell and no unpaired electron is available for metallic bonding.
- (b)**
- (i) Carbonyl  $M(CO)_5$  is  $Fe(CO)_5$   
According to EAN rule, the effective number of a metal in a metal carbonyl is equal to the atomic number of nearest inert gas EAN is calculated as  
EAN = number of electrons in metal +  $2 \times$  (CO)  
= atomic number of nearest inert gas  
In  $M(CO)_5 = x + 2 \times (5) = 36$  (Kr is the nearest inert gas)  
 $x = 26$  (atomic number of metal)  
So, the metal is Fe(iron).
  - (ii)  $MO_3F$  is  $MnO_3F$ .  
In  $MO_3F$   
Let us assume that oxidation state of *M* is *x*  
 $x + 3 \times (-2) + (-1) = 0$   
or,  $x = +7$  i.e., *M* is in +7 oxidation state of +7. Hence, the given compound is  $MnO_3F$ .

**Q. 69** Mention the type of compounds formed when small atoms like H, C and N get trapped inside the crystal lattice of transition metals. Also give physical and chemical characteristics of these compounds.

**Ans.** When small atoms like H, C and N get trapped inside the crystal lattice of transition metals.

- (a) Such compounds are called interstitial compounds.
- (b) Their characteristic properties are;
  - (i) They have high melting points, higher than those of pure metals.
  - (ii) They are very hard.
  - (iii) They retain metallic conductivity.
  - (iv) They are chemically inert.

**Q. 70** (a) Transition metals can act as catalysts because these can change their oxidation state. How does Fe (III) catalyse the reaction between iodide and persulphate ions?

(b) Mention any three processes where transition metals act as catalysts.

**Ans. (a)** Reaction between iodide and persulphate ions is

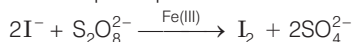

Role of Fe(III) ions

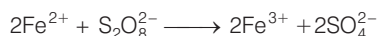

- (b) (i) Vanadium (V) oxide used in contact process for oxidation of  $\text{SO}_2$  to  $\text{SO}_3$ .  
 (ii) Finely divided iron in Haber's process in conversion of  $\text{N}_2$  and  $\text{H}_2$  to  $\text{NH}_3$ .  
 (iii)  $\text{MnO}_2$  in preparation of oxygen from  $\text{KClO}_3$ .

**Q. 71** A violet compound of manganese (A) decomposes on heating to liberate oxygen and compounds (B) and (C) of manganese are formed. Compound (C) reacts with  $\text{KOH}$  in the presence of potassium nitrate to give compound (B). On heating compound (C) with conc.  $\text{H}_2\text{SO}_4$  and  $\text{NaCl}$ , chlorine gas is liberated and a compound (D) of manganese along with other products is formed. Identify compounds A to D and also explain the reactions involved.

💡 **Thinking Process**

*This problem is based on preparation and properties of  $\text{KMnO}_4$ ,  $\text{K}_2\text{MnO}_4$  and  $\text{MnO}_2$ .*

**Ans.** Since, compound (C) on treating with conc.  $\text{H}_2\text{SO}_4$  and  $\text{NaCl}$  gives  $\text{Cl}_2$  gas, so it is manganese dioxide ( $\text{MnO}_2$ ). It is obtained along with  $\text{MnO}_4^{2-}$  when  $\text{KMnO}_4$  (violet) is heated.

Thus, (A) =  $\text{KMnO}_4$                       (B) =  $\text{K}_2\text{MnO}_4$   
 (C) =  $\text{MnO}_2$                               (D) =  $\text{MnCl}_2$

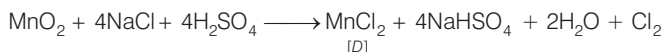
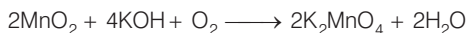
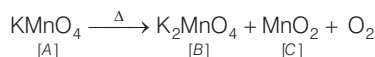

# Coordination Compounds

## Multiple Choice Questions (MCQs)

**Q. 1** Which of the following complexes formed by  $\text{Cu}^{2+}$  ions is most stable?

- (a)  $\text{Cu}^{2+} + 4\text{NH}_3 \longrightarrow [\text{Cu}(\text{NH}_3)_4]^{2+}$ ,  $\log K = 11.6$   
 (b)  $\text{Cu}^{2+} + 4\text{CN}^- \longrightarrow [\text{Cu}(\text{CN})_4]^{2-}$ ,  $\log K = 27.3$   
 (c)  $\text{Cu}^{2+} + 2\text{en}^- \longrightarrow [\text{Cu}(\text{en})_2]^{2+}$ ,  $\log K = 15.4$   
 (d)  $\text{Cu}^{2+} + 4\text{H}_2\text{O} \longrightarrow [\text{Cu}(\text{H}_2\text{O})_4]^{2+}$ ,  $\log K = 8.9$

**Ans. (b)** Greater the value of  $\log K$ , greater will be stability of complex compound formed.  
 For reaction,

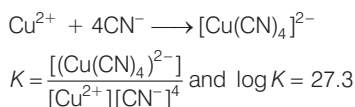

For this reaction,  $\log K$  has highest value among the given four reactions. Hence,  $K$  will also be higher among these four. *i.e.*, stability of the complexes will be highest among these four complexes.

**Q. 2** The colour of the coordination compounds depends on the crystal field splitting. What will be the correct order of absorption of wavelength of light in the visible region, for the complexes,  $[\text{Co}(\text{NH}_3)_6]^{3+}$ ,  $[\text{Co}(\text{CN})_6]^{3-}$ ,  $[\text{Co}(\text{H}_2\text{O})_6]^{3+}$

- (a)  $[\text{Co}(\text{CN})_6]^{3-} > [\text{Co}(\text{NH}_3)_6]^{3+} > [\text{Co}(\text{H}_2\text{O})_6]^{3+}$   
 (b)  $[\text{Co}(\text{NH}_3)_6]^{3+} > [\text{Co}(\text{H}_2\text{O})_6]^{3+} > [\text{Co}(\text{CN})_6]^{3-}$   
 (c)  $[\text{Co}(\text{H}_2\text{O})_6]^{3+} > [\text{Co}(\text{NH}_3)_6]^{3+} > [\text{Co}(\text{CN})_6]^{3-}$   
 (d)  $[\text{Co}(\text{CN})_6]^{3-} > [\text{Co}(\text{NH}_3)_6]^{3+} > [\text{Co}(\text{H}_2\text{O})_6]^{3+}$

### Thinking Process

This problem is based on the concept of crystal field splitting and colour of coordination compounds. Follow the steps to answer this question

- (i) Arrange the given complexes in increasing order of their crystal field splitting energy.  
 (ii) Now arrange them in decreasing order of the wavelength of light.

(iii) As energy and wavelength are related as  $\Delta E = h\nu = \frac{hc}{\lambda}$

**Ans. (c)** As we know that, strong field ligand split the five degenerate energy levels with more energy separation than weak field ligand, *i.e.*, as strength of ligand increases crystal field splitting energy increases.

Hence, 
$$\Delta E = \frac{hc}{\lambda}$$

$$\Rightarrow \Delta E \propto \frac{1}{\lambda} \Rightarrow \lambda \propto \frac{1}{\Delta E}$$

As energy separation increases, the wavelength decreases.

Thus, the correct order is

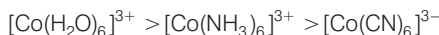

Here, strength of ligand increases,  $\Delta E$  increases, CFSE increases and  $\lambda$  absorbed decreases.

Hence, correct choice is (c).

**Q. 3** When 0.1 mol  $\text{CoCl}_3(\text{NH}_3)_5$  is treated with excess of  $\text{AgNO}_3$ , 0.2 mol of  $\text{AgCl}$  are obtained. The conductivity of solution will correspond to

- (a) 1 : 3 electrolyte (b) 1 : 2 electrolyte  
(c) 1 : 1 electrolyte (d) 3 : 1 electrolyte

**Ans. (b)** One mole of  $\text{AgNO}_3$  precipitates one mole of chloride ion. In the above reaction, when 0.1 mole  $\text{CoCl}_3(\text{NH}_3)_5$  is treated with excess of  $\text{AgNO}_3$ , 0.2 mole of  $\text{AgCl}$  are obtained thus, there must be two free chloride ions in the solution of electrolyte.

So, molecular formula of complex will be  $[\text{Co}(\text{NH}_3)_5\text{Cl}]\text{Cl}_2$  and electrolytic solution must contain  $[\text{Co}(\text{NH}_3)_5\text{Cl}]^{2+}$  and two  $\text{Cl}^-$  as constituent ions. Thus, it is 1 : 2 electrolyte.

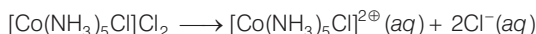

Hence, option (b) is the correct.

**Q. 4** When 1 mole of  $\text{CrCl}_3 \cdot 6\text{H}_2\text{O}$  is treated with excess of  $\text{AgNO}_3$ , 3 moles of  $\text{AgCl}$  are obtained. The formula of the complex is

- (a)  $[\text{CrCl}_3(\text{H}_2\text{O})_3] \cdot 3\text{H}_2\text{O}$  (b)  $[\text{CrCl}_2(\text{H}_2\text{O})_4]\text{Cl} \cdot 2\text{H}_2\text{O}$   
(c)  $[\text{CrCl}(\text{H}_2\text{O})_5]\text{Cl}_2 \cdot \text{H}_2\text{O}$  (d)  $[\text{Cr}(\text{H}_2\text{O})_6]\text{Cl}_3$

**Ans. (d)** 1 mole of  $\text{AgNO}_3$  precipitates one free chloride ion ( $\text{Cl}^-$ ).

Here, 3 moles of  $\text{AgCl}$  are precipitated by excess of  $\text{AgNO}_3$ . Hence, there must be three free  $\text{Cl}^-$  ions.

So, the formula of the complex can be  $[\text{Cr}(\text{H}_2\text{O})_6]\text{Cl}_3$  and correct choice is (d).

**Q. 5** The correct IUPAC name of  $[\text{Pt}(\text{NH}_3)_2\text{Cl}_2]$  is

- (a) Diamminedichloridoplatinum (II)  
(b) Diamminedichloridoplatinum (IV)  
(c) Diamminedichloridoplatinum (0)  
(d) Dichloridodiammineplatinum (IV)

### Thinking Process

*This problem is based on IUPAC nomenclature of coordination compound. IUPAC nomenclature of any coordination compound can be done as follows*

- (i) Positively charged ions are named first.  
(ii) Negatively charged ions are named in alphabetical order of ligands including their numbers followed by metal ending with *-ium* and oxidation state in the bracket.



**Q. 9** Due to the presence of ambidentate ligands coordination compounds show isomerism. Palladium complexes of the type  $[\text{Pd}(\text{C}_6\text{H}_5)_2(\text{SCN})_2]$  and  $[\text{Pd}(\text{C}_6\text{H}_5)_2(\text{NCS})_2]$  are

- (a) linkage isomers (b) coordination isomers  
(c) ionisation isomers (d) geometrical isomers

**Ans. (a)** The ligand(s) which has two different bonding sites are known as ambident ligands e.g., NCS,  $\text{NO}_2$  etc.

Here, NCS has two binding sites at N and S.

Hence, NCS (thiocyanate) can bind to the metal ion in two ways



Thus, coordination compounds containing NCS as a ligand can show linkage isomerism i.e.,  $[\text{Pd}(\text{C}_6\text{H}_5)_2(\text{SCN})_2]$  and  $[\text{Pd}(\text{C}_6\text{H}_5)_2(\text{NCS})_2]$  are linkage isomers.

Hence, correct choice is (a).

**Q. 10** The compounds  $[\text{Co}(\text{SO}_4)(\text{NH}_3)_5]\text{Br}$  and  $[\text{Co}(\text{SO}_4)(\text{NH}_3)_5]\text{Cl}$  represent

- (a) linkage isomerism (b) ionisation isomerism  
(c) coordination isomerism (d) no isomerism

**Ans. (d)** Compounds having same molecular formula but different structural formula are known as isomers.  $[\text{Co}(\text{SO}_4)_2(\text{NH}_3)_5]\text{Br}$  and  $[\text{Co}(\text{SO}_4)(\text{NH}_3)_5]\text{Cl}$  have not same molecular formula. Hence, they are not isomers.

**Q. 11** A chelating agent has two or more than two donor atoms to bind to a single metal ion. Which of the following is not a chelating agent?

- (a) Thiosulphato (b) Oxalato  
(c) Glycinato (d) Ethane-1, 2-diamine

**Ans. (a)** A chelating ligand has two or more binding donor atoms to a single metal ion e.g.,

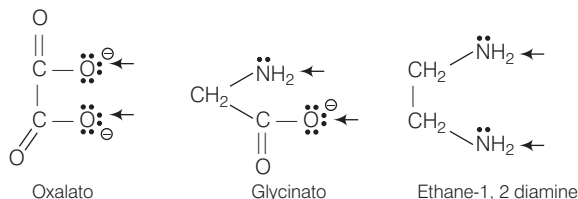

Here ( $\leftarrow$ ) denotes binding site.

thiosulphato ( $\text{S}_2\text{O}_3^{2-}$ ) is not a chelating ligand because geometrically it is not favourable for  $\text{S}_2\text{O}_3^{2-}$  to chelate a metal ion.

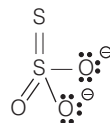

**Q. 12** Which of the following species is not expected to be a ligand?

- (a) NO (b)  $\text{NH}_4^+$   
(c)  $\text{NH}_2\text{CH}_2\text{CH}_2\text{NH}_2$  (d) CO

**Ans. (b)** Ligand must donate a pair of electron or loosely held electron pair to metal and form a  $M-L$  bond.

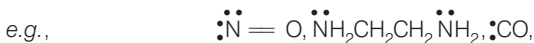

Among  $\text{NH}_4^+$  does not have any pair of electron.

Hence  $\text{NH}_4^+$  is not a ligand.

**Q. 13** What kind of isomerism exists between  $[\text{Cr}(\text{H}_2\text{O})_6]\text{Cl}_3$  (violet) and  $[\text{Cr}(\text{H}_2\text{O})_5\text{Cl}]\text{Cl}_2 \cdot \text{H}_2\text{O}$  (greyish-green)?

- (a) Linkage isomerism
- (b) Solvate isomerism
- (c) Ionisation isomerism
- (d) Coordination isomerism

**Ans. (c)** Solvate isomerism is shown when two compounds having same molecular formula differ by whether or solvent molecule is directly bonded to metal ion or is present as free solvent molecules in the crystal lattice.

When water is present as solvent and show this type of isomerism then it is known as hydrate isomerism.

Coordination compound  $[\text{Cr}(\text{H}_2\text{O})_6]\text{Cl}_3$  and  $[\text{Cr}(\text{H}_2\text{O})_5\text{Cl}]\text{H}_2\text{O} \cdot \text{Cl}_2$  are solvate isomers, because water is exchanged by chloride ion. This is why both of them show different colour on exposure to sunlight.

**Q. 14** IUPAC name of  $[\text{Pt}(\text{NH}_3)_2\text{Cl}(\text{NO}_2)]$  is

- (a) Platinum diaminechloronitrite
- (b) Chloronitrito-N-ammineplatinum (II)
- (c) Diamminechloridonitrito-N-platinum (II)
- (d) Diamminechloronitrito-N-platinate (II)

**Ans. (c)** Correct IUPAC name can be written as

*The ligands present in the given coordination compound are*

- (i)  $\text{NH}_3$  represented as amine
- (ii)  $\text{Cl}^-$  represented as chlorido
- (iii)  $\text{NO}_2^-$  represented as nitrito-N

According to IUPAC rule, ligands are named in an alphabetical order before central atom. Prefix di- will be used to indicate the number of  $\text{NH}_3$  ligands present.

Oxidation state of metal is indicated by Roman numeral in parenthesis.

So, IUPAC name will be

diamminechloronitrito-N-platinum (II)

Hence, option (c) is correct.



## Multiple Choice Questions (More Than One Options)

**Q. 15** Atomic number of Mn, Fe and Co are 25, 26 and 27 respectively. Which of the following inner orbital octahedral complex ions are diamagnetic?

- (a)  $[\text{Co}(\text{NH}_3)_6]^{3+}$  (b)  $[\text{Mn}(\text{CN})_6]^{3-}$  (c)  $[\text{Fe}(\text{CN})_6]^{4-}$  (d)  $[\text{Fe}(\text{CN})_6]^{3-}$

**Thinking Process**

This problem is based on magnetic property of coordination compound. Coordination compound containing at least one unpaired electron(s) are paramagnetic and coordination compounds all containing all paired electrons are diamagnetic in nature.

**Ans. (a, c)**

Molecular orbital electronic configuration of  $\text{Co}^{3+}$  in  $[\text{Co}(\text{NH}_3)_6]^{3+}$  is

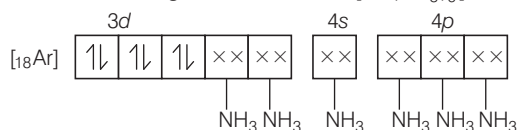

Number of unpaired electron = 0

Magnetic property = Diamagnetic

Molecular orbital electronic configuration of  $\text{Mn}^{3+}$  in  $[\text{Mn}(\text{CN})_6]^{3-}$

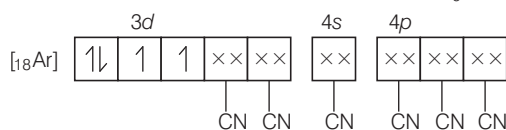

Number of unpaired electrons = 2

Magnetic property = Paramagnetic

Molecular orbital electronic configuration of  $\text{Fe}^{2+}$  in  $[\text{Fe}(\text{CN})_6]^{4-}$  is

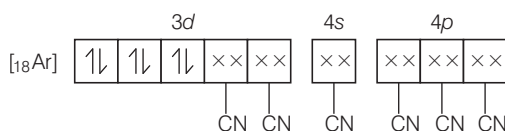

Number of unpaired electron = 0

Magnetic property = Diamagnetic

Molecular orbital electronic configuration of  $\text{Fe}^{3+}$  in  $[\text{Fe}(\text{CN})_6]^{3-}$

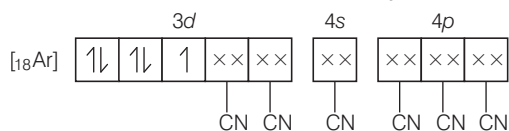

Number of unpaired electron = 1

Magnetic property = Paramagnetic

Thus,  $[\text{Co}(\text{NH}_3)_6]^{3+}$  and  $[\text{Fe}(\text{CN})_6]^{4-}$  are diamagnetic.

Hence, correct choices are options (a) and (c).

**Q. 16** Atomic number of Mn, Fe, Co and Ni are 25, 26, 27 and 28 respectively. Which of the following outer orbital octahedral complexes have same number of unpaired electrons?

- (a)  $[\text{MnCl}_6]^{3-}$  (b)  $[\text{FeF}_6]^{3-}$   
 (c)  $[\text{CoF}_6]^{3-}$  (d)  $[\text{Ni}(\text{NH}_3)_6]^{2+}$

Ans. (a, c)

Molecular orbital electronic configuration of  $Mn^{3+}$  in  $[MnCl_6]^{3-}$  is

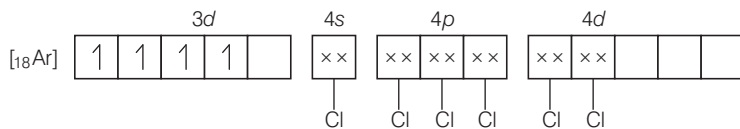

Number of unpaired electrons = 4

Magnetic property = Paramagnetic

Molecular orbital electronic configuration of  $Co^{3+}$  in  $[CoF_6]^{3-}$  is

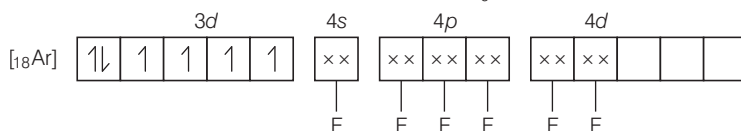

Number of unpaired electrons = 4

Magnetic property = Paramagnetic

Molecular orbital electronic configuration of  $Fe^{3+}$  in  $[FeF_6]^{3-}$  is

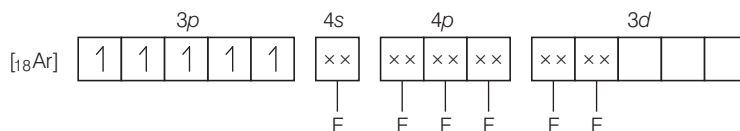

Number of unpaired electrons = 5

Magnetic property = Paramagnetic

Molecular orbital electronic configuration of  $Ni^{2+}$  in  $[Ni(NH_3)_6]^{2+}$  is

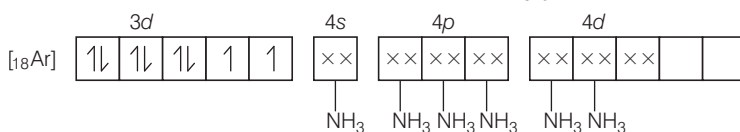

Number of unpaired electrons = 2

Magnetic property = Paramagnetic

Thus,  $[MnCl_6]^{3-}$  and  $[CoF_6]^{3-}$  are paramagnetic having four electrons each.

Hence, correct choices are (a) and (c).

Q. 17 Which of the following options are correct for  $[Fe(CN)_6]^{3-}$  complex?

- (a)  $d^2sp^3$  hybridisation
- (b)  $sp^3d^2$  hybridisation
- (c) Paramagnetic
- (d) Diamagnetic

Ans. (a, c)

According to VBT, the molecular orbital electronic configuration of  $Fe^{3+}$  in  $[Fe(CN)_6]^{3-}$  is

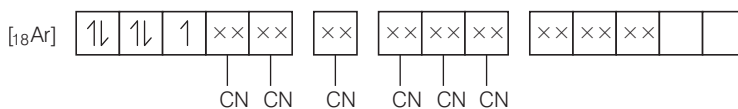

Hybridisation =  $d^2sp^3$

Number of unpaired electron = 1

Magnetic property = Paramagnetic

Hence, correct choices are options (a) and (c).

**Q. 18** An aqueous pink solution of cobalt(II) chloride changes to deep blue on addition of excess of HCl. This is because .....

- (a)  $[\text{Co}(\text{H}_2\text{O})_6]^{2+}$  is transformed into  $[\text{CoCl}_6]^{4-}$   
 (b)  $[\text{Co}(\text{H}_2\text{O})_6]^{2+}$  is transformed into  $[\text{CoCl}_4]^{2-}$   
 (c) tetrahedral complexes have smaller crystal field splitting than octahedral complexes  
 (d) tetrahedral complexes have larger crystal field splitting than octahedral complex

**Ans. (b, c)**

Aqueous pink solution of cobalt (II) chloride is due to electronic transition of electron from  $t_{2g}$  to  $e_g$  energy level of  $[\text{Co}(\text{H}_2\text{O})_6]^{2+}$  complex. When excess of HCl is added to this solution

- (i)  $[\text{Co}(\text{H}_2\text{O})_6]^{2+}$  is transformed into  $[\text{CoCl}_4]^{2-}$ .  
 (ii) Tetrahedral complexes have smaller crystal field splitting than octahedral complexes because  $\Delta_t = \frac{4}{9}\Delta_0$

Hence, options (b) and (c) are correct choices.

**Q. 19** Which of the following complexes are homoleptic?

- (a)  $[\text{Co}(\text{NH}_3)_6]^{3+}$  (b)  $[\text{Co}(\text{NH}_3)_4\text{Cl}_2]^+$   
 (c)  $[\text{Ni}(\text{CN})_4]^{2-}$  (d)  $[\text{Ni}(\text{NH}_3)_4\text{Cl}_2]$

**Ans. (a, c)**

**Homoleptic complex** The complex containing only one species or group as ligand is known as homoleptic ligand.

e.g.,  $[\text{Co}(\text{NH}_3)_6]^{3+}$ ,  $[\text{Ni}(\text{CN})_4]^{2-}$

Here,  $[\text{Co}(\text{NH}_3)_6]^{3+}$  contain only  $\text{NH}_3$  as a ligand and  $[\text{Ni}(\text{CN})_4]^{2-}$  contain CN as a ligand. While other two complexes  $[\text{Co}(\text{NH}_3)_4\text{Cl}_2]^+$  and  $[\text{Ni}(\text{NH}_3)_4\text{Cl}_2]$  contain  $\text{NH}_3$  and Cl as ligands.

Hence, options (a) and (c) are correct choices.

**Q. 20** Which of the following complexes are heteroleptic?

- (a)  $[\text{Cr}(\text{NH}_3)_6]^{3+}$  (b)  $[\text{Fe}(\text{NH}_3)_4\text{Cl}_2]^+$   
 (c)  $[\text{Mn}(\text{CN})_6]^{4-}$  (d)  $[\text{Co}(\text{NH}_3)_4\text{Cl}_2]$

**Ans. (b, d)**

**Heteroleptic complexes** Coordination complexes which contain more than one type of ligands are known as heteroleptic complexes.

e.g.,  $[\text{Fe}(\text{NH}_3)_4\text{Cl}_2]^+$  contain  $\text{NH}_3$  and Cl as a ligand is as heteroleptic complex. Similarly,  $[\text{Co}(\text{NH}_3)_4\text{Cl}_2]$  contain  $\text{NH}_3$  and Cl as ligand is also a heteroleptic complex.

Hence, options (b) and (d) are correct choices.

**Q. 21** Identify the optically active compounds from the following

- (a)  $[\text{Co}(\text{en})_3]^{3+}$  (b) *trans* -  $[\text{Co}(\text{en})_2\text{Cl}_2]^+$   
 (c) *cis* -  $[\text{Co}(\text{en})_2\text{Cl}_2]^+$  (d)  $[\text{Cr}(\text{NH}_3)_5\text{Cl}]$



$[\text{Cr}(\text{NH}_3)_5\text{SCN}]^{2+}$  contains SCN which have two different donor sites S and N can be shown by arrow ( $\rightarrow$ ) as



Hence,  $[\text{Co}(\text{NH}_3)_5(\text{NO}_2)]^{2+}$  and  $[\text{Cr}(\text{NH}_3)_5\text{SCN}]^{2+}$  show linkage isomerism. While  $[\text{Co}(\text{H}_2\text{O})_5\text{CO}]^{3+}$  and  $[\text{Fe}(\text{en})_2\text{Cl}_2]^+$  has no ambident ligand. So, these two will not show linkage isomerism.

Hence, options (a) and (c) are correct choices.

## Short Answer Type Questions

**Q. 24** Arrange the following complexes in the increasing order of conductivity of their solution



### Thinking Process

*This problem is based on the concept of conductivity of coordination compound. Greater the number of ions, greater the conductivity of coordination compound.*

**Ans.** Ions or molecules present outside the coordination sphere are ionisable. A complex which gives more ions on dissolution, is more conducting.

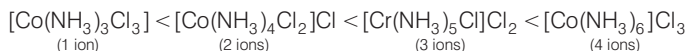

Here, number of ions increases and conductivity increases.

**Q. 25** A coordination compound  $\text{CrCl}_3 \cdot 4\text{H}_2\text{O}$  precipitates silver chloride when treated with silver nitrate. The molar conductance of its solution corresponds to a total of two ions. Write structural formula of the compound and name it.

**Ans.** Formation of white precipitate with  $\text{AgNO}_3$  shows that atleast one Cl ion is present outside the coordination sphere. Moreover only two ions are obtained in solution, so only one  $\text{Cl}^-$  is present outside the sphere.

Thus, the formula of the complex is  $[\text{Co}(\text{H}_2\text{O})_4\text{Cl}_2]\text{Cl}$  and its IUPAC name is Tetraaquadichloridocobalt (III) chloride.

**Q. 26** A complex of the type  $[\text{M}(\text{AA})_2\text{X}_2]^{n+}$  is known to be optically active. What does this indicate about the structure of the complex? Give one example of such complex.

**Ans.** An optically active complex of the type  $[\text{M}(\text{AA})_2\text{X}_2]^{n+}$  indicates *cis*-octahedral structure, e.g., *cis*- $[\text{Pt}(\text{en})_2\text{Cl}_2]^{2+}$  or *cis*- $[\text{Cr}(\text{en})_2\text{Cl}_2]^+$  because its mirror image isomers are non-superimposable.

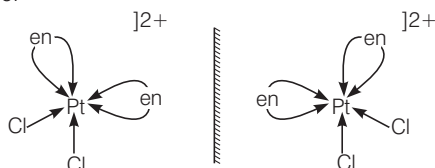

**Non-superimposable isomers of  $[\text{Pt}(\text{en})_2\text{Cl}_2]^{2+}$**

Non-superimposable isomers of  $[\text{Pt}(\text{en})_2\text{Cl}_2]^{2+}$ .

**Q. 27** Magnetic moment of  $[\text{MnCl}_4]^{2-}$  is 5.92 BM. Explain giving reason present.

**Ans.** The magnetic moment 5.92 BM shows that there are five unpaired electrons present in the  $d$ -orbitals of  $\text{Mn}^{2+}$  ion. As a result, the hybridisation involved is  $sp^3$  rather than  $dsp^2$ . Thus tetrahedral structure of  $[\text{MnCl}_4]^{2-}$  complex will show 5.92 BM magnetic moment value.

**Q. 28** On the basis of crystal field theory explain why  $\text{Co(III)}$  forms paramagnetic octahedral complex with weak field ligands whereas it forms diamagnetic octahedral complex with strong field ligands.

**Ans.** With weak field ligands;  $\Delta_o < P$ , (pairing energy) so, the electronic configuration of  $\text{Co(III)}$  will be  $t_{2g}^4 e_g^2$  i.e., it has 4 unpaired electrons and is paramagnetic.

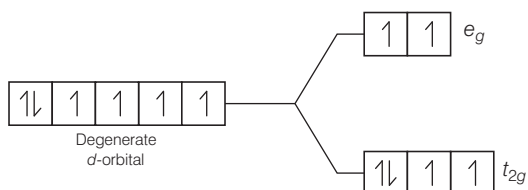

With strong field ligands,  $\Delta_o > P$  (pairing energy), so pairing occurs thus, the electronic configuration will be  $t_{2g}^6 e_g^0$ . It has no unpaired electrons and is diamagnetic.

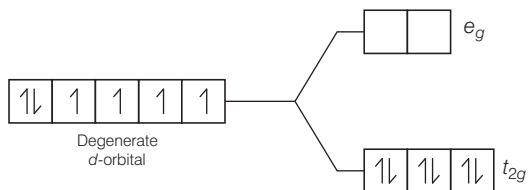

**Q. 29** Why are low spin tetrahedral complexes not formed?

**Ans.** In tetrahedral complex, the  $d$ -orbital is splitting to small as compared to octahedral. For same metal and same ligand  $\Delta_t = \frac{4}{9} \Delta_o$ .

Hence, the orbital splitting energies are not enough to force pairing. As a result, low spin configurations are rarely observed in tetrahedral complexes.

**Q. 30** Give the electronic configuration of the following complexes on the basis of crystal field splitting theory.  $[\text{CoF}_6]^{3-}$ ,  $[\text{Fe}(\text{CN})_6]^{4-}$  and  $[\text{Cu}(\text{NH}_3)_6]^{2+}$ .

**Ans.** According to spectrochemical series, ligands can be arranged in a series in the order of increasing field strength i.e.,  $\text{F}^- < \text{NH}_3 < \text{CN}^-$ .

Hence,  $\text{CN}^-$  and  $\text{NH}_3$  being strong field ligand pair up the  $t_{2g}$  electrons before filling  $e_g$  set.  $[\text{CoF}_6]^{3-}; \text{Co}^{3+} = (d^6) t_{2g}^4 e_g^2$

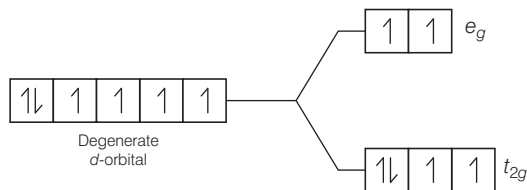

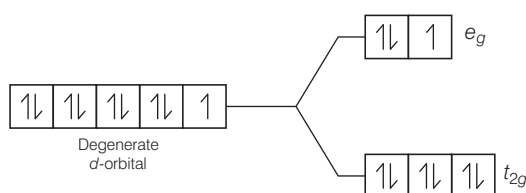
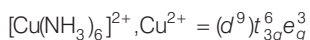
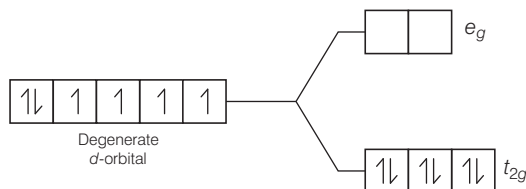
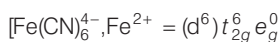

**Q. 31** Explain why  $[\text{Fe}(\text{H}_2\text{O})_6]^{3+}$  has magnetic moment value of 5.92 BM whereas  $[\text{Fe}(\text{CN})_6]^{3-}$  has a value of only 1.74 BM?

**Ans.** As we know,  
where,

$$\mu_m = \sqrt{n(n+2)} \text{ BM}$$

$\mu_m$  = magnetic moment

$\mu_n$  = number of unpaired electrons

It

$$\mu_m = 1.74 \text{ i.e., } n = 1$$

and

$$\mu_m = 5.92 \text{ i.e., } n = 5$$

$[\text{Fe}(\text{CN})_6]^{3-}$  involves  $d^2sp^3$  hybridisation with one unpaired electron (as shown by its magnetic moment 1.74 BM) and  $[\text{Fe}(\text{H}_2\text{O})_6]^{3+}$  involves  $sp^3d^2$  hybridisation with five unpaired electrons (because magnetic moment equal to 5.92 BM).

$\text{CN}^-$  is stronger ligand than  $\text{H}_2\text{O}$  according to spectrochemical series.  $\Delta_0 > P$  for  $\text{CN}^-$  hence, fourth electron will pair itself. Whereas for water pairing will not happen for  $[\text{Fe}(\text{CN})_6]^{3-}$  the electronic configuration of  $\text{Fe}^{3+}$  is

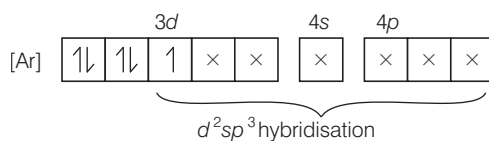

One unpaired electron

For  $[\text{Fe}(\text{H}_2\text{O})_6]^{3+}$  the electronic configuration of  $\text{Fe}^{3+}$  is

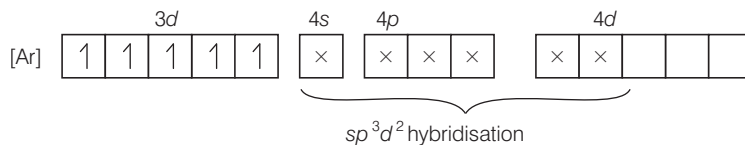

Five unpaired electron

Hence,  $[\text{Fe}(\text{CN})_6]^{3-}$  and  $[\text{Fe}(\text{H}_2\text{O})_6]^{3+}$  are inner orbital and outer orbital complex respectively.

**Q. 32** Arrange following complex ions in increasing order of crystal field splitting energy ( $\Delta_0$ ).

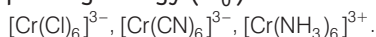

**Ans.** CFSE is higher when the complex contains strong field ligand. Thus, crystal field splitting energy increases in the order

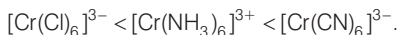

Because according to spectrochemical series the order of field strength is

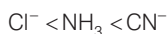

**Q. 33** Why do compounds having similar geometry have different magnetic moment?

**Ans.** It is due to the presence of weak and strong field ligands in complexes. If CFSE is high, the complex will show low value of magnetic moment and *vice-versa*, e.g.  $[\text{CoF}_6]^{3-}$  and  $[\text{Co}(\text{NH}_3)_6]^{3+}$ , the former is paramagnetic, and the latter is diamagnetic because  $\text{F}^-$  is a weak field ligand and  $\text{NH}_3$  is a strong field ligand while both have similar geometry.

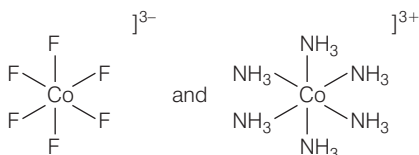

**Q. 34**  $\text{CuSO}_4 \cdot 5\text{H}_2\text{O}$  is blue in colour while  $\text{CuSO}_4$  is colourless. Why?

**Ans.** In  $\text{CuSO}_4 \cdot 5\text{H}_2\text{O}$ , water acts as ligand and causes crystal field splitting. Hence, *d-d* transition is possible thus  $\text{CuSO}_4 \cdot 5\text{H}_2\text{O}$  is coloured. In the anhydrous  $\text{CuSO}_4$  due to the absence of water (ligand), crystal field splitting is not possible and hence, it is colourless.

**Q. 35** Name the type of isomerism when ambidentate ligands are attached to central metal ion. Give two examples of ambidentate ligands.

**Ans.** Ligand having more than one different binding position are known as ambidentate ligand. e.g.,  $\text{SCN}^-$  has two different binding positions S and N. Coordination compound containing ambidentate ligands are considered to show linkage isomerism due to presence of two different binding positions.

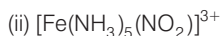



## Matching The Columns

**Q. 36** Match the complex ions given in Column I with the colours given in Column II and assign the correct code.

Column I (Complex ion)	Column II (Colour)
A. $[\text{Co}(\text{NH}_3)_6]^{3+}$	1. Violet
B. $[\text{Ti}(\text{H}_2\text{O})_6]^{3+}$	2. Green
C. $[\text{Ni}(\text{H}_2\text{O})_6]^{2+}$	3. Pale blue
D. $[\text{Ni}(\text{H}_2\text{O})_4(\text{en})]^{2+} (\text{aq})$	4. Yellowish orange

**Codes**

A	B	C	D	A	B	C	D
(a) 1	2	4	5	(b) 4	3	2	1
(c) 3	2	4	1	(d) 4	1	2	3

**Ans. A.** → (4)    **B.** → (3)    **C.** → (2)    **D.** → (1)

Colour of coordination compound is closely related to CFSE of coordination compound. Depending upon the CFSE of given coordination compounds. Correct matching will be as follows

Column I (Complex ion)	Column II (Colour)
A. $[\text{Co}(\text{NH}_3)_6]^{3+}$	4. Yellowish orange
B. $[\text{Ti}(\text{H}_2\text{O})_6]^{3+}$	3. Pale blue
C. $[\text{Ni}(\text{H}_2\text{O})_6]^{2+}$	2. Green
D. $[\text{Ni}(\text{H}_2\text{O})_4(\text{en})]^{2+} (\text{aq})$	1. Violet

Hence, correct choice is (b).

**Q. 37** Match the coordination compounds given in Column I with the central metal atoms given in Column II and assign the correct code.

Column I (Coordination compound)	Column II (Central metal atom)
A. Chlorophyll	1. Rhodium
B. Blood pigment	2. Cobalt
C. Wilkinson catalyst	3. Magnesium
D. Vitamin $\text{B}_{12}$	4. Iron

**Codes**

A	B	C	D	A	B	C	D
(a) 3	4	1	2	(b) 3	4	5	1
(c) 4	3	2	1	(d) 3	4	1	2

Ans. A. → (3) B. → (4) C. → (1) D. → (2)

Central metal ions present on coordination compounds determine the properties of coordination compound and their biological role.

Column I (Coordination compound)	Column II (Central metal atom)
A. Chlorophyll	3. Magnesium
B. Blood pigment	4. Iron
C. Wilkinson catalyst	1. Rhodium
D. Vitamin B <sub>12</sub>	2. Cobalt

Hence, correct choice is (a).

**Q. 38** Match the complex ions given in Column I with the hybridisation and number of unpaired electrons given in Column II and assign the correct code.

Column I (Complex ion)	Column II (Hybridisation, number of unpaired electrons)
A. $[\text{Cr}(\text{H}_2\text{O})_6]^{3+}$	1. $ds^2, 1$
B. $[\text{Co}(\text{CN})_4]^{2-}$	2. $sp^3 d^2, 5$
C. $[\text{Ni}(\text{NH}_3)_6]^{2+}$	3. $d^2 sp^3, 3$
D. $[\text{MnF}_6]^{4-}$	4. $sp^3 d^2, 2$

Codes

A B C D  
(a) 3 1 4 2  
(c) 3 2 4 1

A B C D  
(b) 4 3 2 1  
(d) 4 1 2 3

Ans. A. → (3) B. → (1) C. → (4) D. → (2)

Formation of inner orbital complex and outer orbital complex determines hybridisation of molecule which *intum* depends upon field strength of ligand and number of vacant *d* orbitals.

(i) Strong field ligand forms inner orbital complex with hybridisation  $d^2 sp^3$ .

(ii) Weak field ligand forms outer orbital complex with hybridisation  $sp^3 d^2$ .

According to VBT, hybridisation and number of unpaired electrons of coordination compounds can be calculated as

A.  $[\text{Cr}(\text{H}_2\text{O})_6]^{3+}$

MOEC (Molecular orbital electronic configuration) of  $\text{Cr}^{3+}$  in  $[\text{Cr}(\text{H}_2\text{O})_6]^{3+}$  is

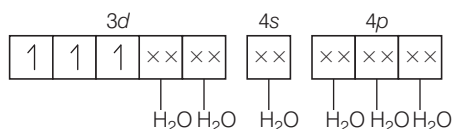

Hybridisation =  $d^2 sp^3$

*n* (number of unpaired electrons) = 3

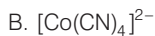
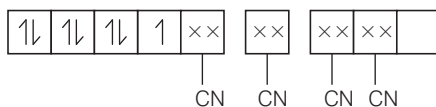
MOEC of  $\text{Co}^{2+}$  in  $[\text{Co}(\text{CN})_4]^{2-}$  isHybridisation =  $dsp^2$ 

$$n = 1$$

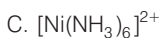
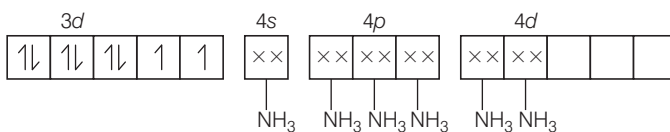
MOEC of  $\text{Ni}^{2+}$  in  $[\text{Ni}(\text{NH}_3)_6]^{2+}$  isHybridisation =  $sp^3d^2$ 

$$n = 2$$

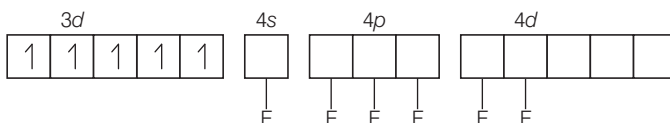
MOEC of  $\text{Mn}^{2+}$  in  $[\text{MnF}_6]^{4-}$  isHybridisation =  $sp^3d^2$ 

$$n = 5$$

Hence, correct choice can be represented by (a).

**Q. 39** Match the complex species given in Column I with the possible isomerism given in Column II and assign the correct code.

Column I (Complex species)	Column II (Isomerism)
A. $[\text{Co}(\text{NH}_3)_4\text{Cl}_2]^+$	1. Optical
B. <i>cis</i> - $[\text{Co}(\text{en})_2\text{Cl}_2]^+$	2. Ionisation
C. $[\text{Co}(\text{NH}_3)_5(\text{NO}_2)]\text{Cl}_2$	3. Coordination
D. $[\text{Co}(\text{NH}_3)_6][\text{Cr}(\text{CN})_6]$	4. Geometrical

Codes

A	B	C	D
(a) 1	2	4	3
(c) 4	2	1	3

A	B	C	D
(b) 4	3	2	1
(d) 4	1	2	3

Ans. A. → (4) B. → (1) C. → (2) D. → (3)

Isomerism in coordination compound is decided by type of ligands and geometry of coordination and arrangement of ligands.

A.  $[\text{Co}(\text{NH}_3)_4\text{Cl}_2]^+$  shows geometrical isomerism due to presence of two types of ligand whose  $[\text{Co}(\text{NH}_3)_4\text{Cl}_2]^+$  arrangement around central metal ion.

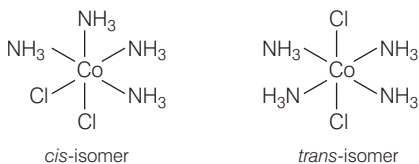

B. *cis* -  $[\text{Co}(\text{en})_2\text{Cl}_2]^+$  shows optical isomer due to its non-superimposable mirror image relationship.

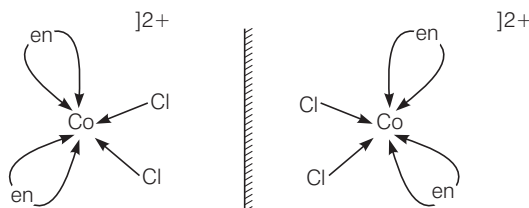

C.  $[\text{Co}(\text{NH}_3)_5(\text{NO}_2)]\text{Cl}_2$  shows ionisation isomer due to its interchanging ligand from outside the ionisation sphere.

D.  $[\text{Co}(\text{NH}_3)_6][\text{Cr}(\text{CN})_6]$  shows coordination isomer due to interchanging of ligand in between two metal ions from one coordination sphere to another coordination sphere.

Hence, correct choice is (d).

**Q. 40** Match the compounds given in Column I with the oxidation state of cobalt present in it (given in column II) and assign the correct code.

Column I (Compound)	Column II (Oxidation state of Co)
A. $[\text{Co}(\text{NCS})(\text{NH}_3)_5](\text{SO}_3)$	1. +4
B. $[\text{Co}(\text{NH}_3)_4\text{Cl}_2]\text{SO}_4$	2. 0
C. $\text{Na}_4[\text{Co}(\text{S}_2\text{O}_3)_3]$	3. +2
D. $[\text{Co}_2(\text{CO})_8]$	4. +3

Code

A	B	C	D	A	B	C	D
(a) 1	2	4	3	(b) 4	3	2	1
(c) 3	1	4	2	(d) 4	1	3	2

Ans. A. → (4) B. → (1) C. → (3) D. → (2)

Oxidation state of CMI (central metal ion) can be calculated by considering the oxidation state of whole molecule is equal to charge present on coordination sphere.

A.  $[\text{Co}(\text{NCS})(\text{NH}_3)_5]\text{SO}_3$ .

Let oxidation state of Co is  $x$ .

$$x - 1 + 5 \times 0 = +2$$

$$x = +2 + 1 = +3$$

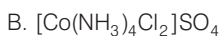
Let oxidation state of Co =  $x$ 

$$\Rightarrow x + 4 \times 0 + 2 \times (-1) = +2$$

$$\Rightarrow x - 2 = +2$$

$$x = 4$$

Let oxidation state of Co =  $x$ 

$$x + 3 \times (-2) = -4$$

$$x - 6 = -4$$

$$x = -4 + 6 = +2$$

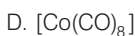
Let oxidation state of Co =  $x$ 

$$x - 8 \times 0 = 0$$

$$x = 0$$

Hence, correct choice is (d).

## Assertion and Reason

*In the following questions a statement of assertion (A) followed by a statement of reason (R) is given. choose the correct answer out of the following choices.*

- (a) Assertion and reason both are true, reason is correct explanation of assertion.
- (b) Assertion and reason both are true but reason is not the correct explanation of assertion.
- (c) Assertion is true, reason is false.
- (d) Assertion is false, reason is true.

**Q. 41** Assertion (A) Toxic metal ions are removed by the chelating ligands.

Reason (R) Chelate complexes tend to be more stable.

**Ans. (a)** Assertion and reason both are correct and reason is the correct explanation of assertion.

Toxic metal ions are removed by chelating ligands. When a solution of chelating ligand is added to solution containing toxic metals ligands chelates the metal ions by formation of stable complex.

**Q. 42** Assertion (A)  $[\text{Cr}(\text{H}_2\text{O}_6)]\text{Cl}_2$  and  $[\text{Fe}(\text{H}_2\text{O})_6]\text{Cl}_2$  are reducing in nature.

Reason (R) Unpaired electrons are present in their d-orbitals.

**Ans. (b)** Assertion and reason both are true but reason is not correct explanation of assertion.

Correct reason is

$[\text{Cr}(\text{H}_2\text{O}_6)]\text{Cl}_2$  and  $[\text{Fe}(\text{H}_2\text{O})_6]\text{Cl}_2$  are reducing in nature due to formation of more stable complex ion after gaining of electron.

**Q. 43** Assertion (A) Linkage isomerism arises in coordination compounds containing ambidentate ligand.

Reason (R) Ambidentate ligand has two different donor atoms.

**Ans. (a)** Assertion and reason both are correct and reason is correct explanation of assertion. Linkage isomerism arises in coordination compounds containing ambidentate ligands because ambidentate ligand has two different donor atoms.  
e.g., SCN, NO<sub>2</sub> etc.

**Q. 44** Assertion (A) Complexes of MX<sub>6</sub> and MX<sub>5</sub>L type (X and L are unidentate) do not show geometrical isomerism.

Reason (R) Geometrical isomerism is not shown by complexes of coordination number 6.

**Ans. (b)** Assertion and reason both are correct and reason is not correct explanation of assertion.

Complexes of MX<sub>6</sub> and MX<sub>5</sub>L type (X and L are unidentate) do not show geometrical isomerism due to presence of plane of symmetry and necessary condition for showing geometrical isomerism is that complex is must of MA<sub>4</sub>B<sub>2</sub> type or [M(AB)<sub>2</sub>X<sub>2</sub>] type

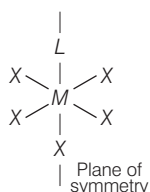

**Q. 45** Assertion (A) [Fe(CN)<sub>6</sub>]<sup>3-</sup> ion shows magnetic moment corresponding to two unpaired electrons.

Reason (R) Because it has d<sup>2</sup>sp<sup>3</sup> type hybridisation.

**Ans. (d)** Assertion is false but reason is true.

According to VBT, MOEC of Fe<sup>3+</sup> in [Fe(CN)<sub>6</sub>]<sup>3-</sup> is

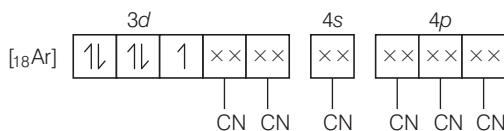

Hybridisation = d<sup>2</sup>sp<sup>3</sup>

$$n = 1$$

Hence, correct assertion is

[Fe(CN)<sub>6</sub>]<sup>3-</sup> ion shows magnetic moment corresponding to one unpaired electron.

i.e.,

$$\begin{aligned} \mu &= \sqrt{n(n+2)} \\ &= \sqrt{1(1+2)} \\ &= \sqrt{3} = 1.73 \text{ BM} \end{aligned}$$

## Long Answer Type Questions

**Q. 46** Using crystal field theory, draw energy level diagram, write electronic configuration of the central metal atom/ion and determine the magnetic moment value in the following

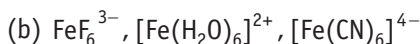
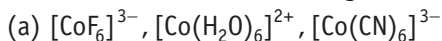

### Thinking Process

This problem includes conceptual mixing of crystal field theory and magnetic moment ( $\mu$ ) determination.

$$\mu = \sqrt{n(n+2)} \text{ BM where, } n = \text{number of unpaired electrons}$$

**Ans. (a)**  $[\text{CoF}_6]^{3-}$ .

$\text{F}^-$  is a weak field ligand.

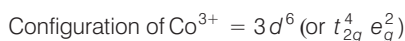
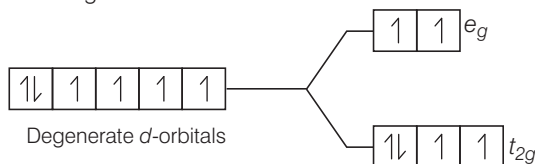

Number of unpaired electrons ( $n$ ) = 4

$$\text{Magnetic moment } (\mu) = \sqrt{n(n+2)} = \sqrt{4(4+2)} = \sqrt{24} = 4.9 \text{ BM}$$

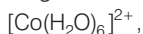

$\text{H}_2\text{O}$  is a weak field ligand.

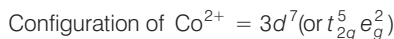
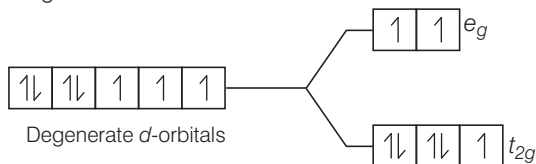

Number of unpaired electrons ( $n$ ) = 3

$$\mu = \sqrt{3(3+2)} = \sqrt{15} = 3.87 \text{ BM}$$

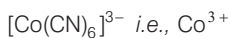

$\therefore$  CN is strong field ligand.

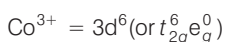
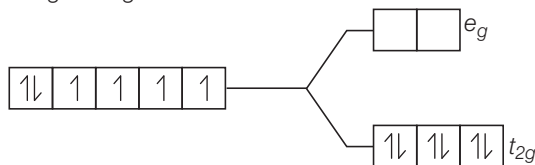

There is no unpaired electron, so it is diamagnetic.

$$\mu = 0$$

(b)  $[\text{FeF}_6]^{3-}$ ,

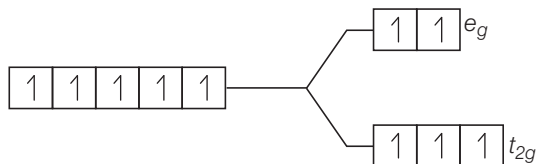

$$\text{Fe}^{3+} = 3d^5 \text{ (or } t_{2g}^3 e_g^2 \text{)}$$

Number of unpaired electrons,  $n = 5$

$$\begin{aligned} \mu &= \sqrt{5(5+2)} \\ &= \sqrt{35} = 5.92 \text{ BM} \end{aligned}$$

$[\text{Fe}(\text{H}_2\text{O})_6]^{2+}$

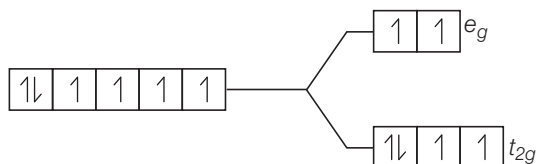

$$\text{Fe}^{2+} = 3d^6 \text{ (or } t_{2g}^4 e_g^2 \text{)}$$

Number of unpaired electrons,  $n = 4$

$$\begin{aligned} \mu &= \sqrt{4(4+2)} \\ Z &= \sqrt{24} \\ &= 4.98 \text{ BM} \end{aligned}$$

$[\text{Fe}(\text{CN})_6]^{4-}$

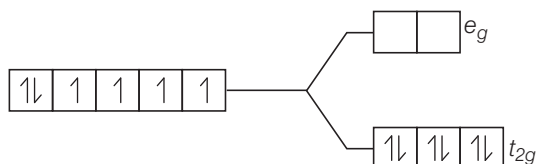

Since,  $\text{CN}^-$  is a strong field ligand, all the electrons get paired.

$$\text{Fe}^{2+} = 3d^6 \text{ (or } t_{2g}^6 e_g^0 \text{)}$$

Because there is no unpaired electron, so it is diamagnetic in nature.

**Q. 47** Using valence bond theory, explain the following in relation to the complexes given below

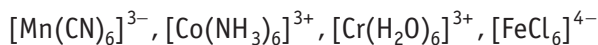

- Type of hybridisation
- Inner or outer orbital complex
- Magnetic behaviour
- Spin only magnetic moment value.



**Ans. (a)**  $[\text{Mn}(\text{CN})_6]^{3-}$

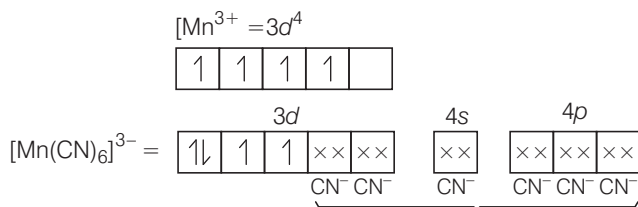

(i)  $d^2sp^3$  hybridisation

(ii) Inner orbital complex because  $(n-1)d$ -orbitals are used.

(iii) Paramagnetic, as two unpaired electrons are present.

(iv) Spin only magnetic moment ( $\mu$ ) =  $\sqrt{2(2+2)} = \sqrt{8} = 2.82$  BM

**(b)**  $[\text{Co}(\text{NH}_3)_6]^{3+}$

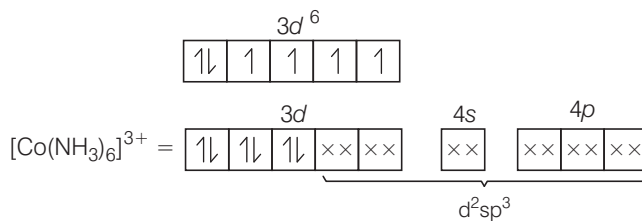
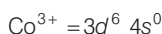

( $\text{NH}_3$  pair up the unpaired  $3d$  electrons.)

(i)  $d^2sp^3$  hybridisation

(ii) Inner orbital complex because of the involvement of  $(n-1)d$ -orbital in bonding.

(iii) Diamagnetic, as no unpaired electron is present.

(iv)  $\mu = \sqrt{n(n+2)} = \sqrt{0(0+2)} = 0$  (Zero)

**(c)**  $[\text{Cr}(\text{H}_2\text{O})_6]^{3+}$

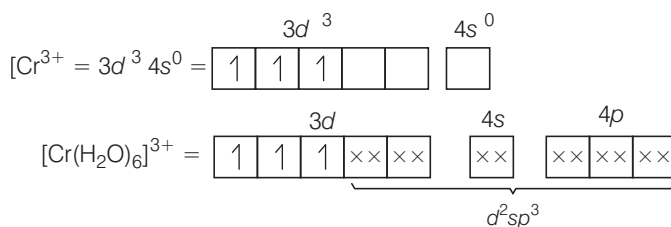

(i)  $d^2sp^3$  hybridisation

(ii) Inner orbital complex (as  $(n-1)d$ -orbital take part.)

(iii) Paramagnetic (as three unpaired electrons are present.)

(iv)  $\mu = \sqrt{n(n+2)} = \sqrt{3(3+2)} = \sqrt{15} = 3.87$  BM

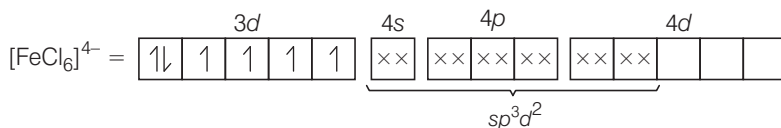
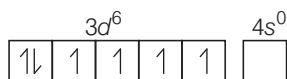
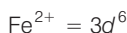
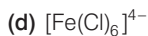

- (i)  $sp^3d^2$  hybridisation
- (ii) Outer orbital complex because  $nd$ -orbitals are involved in hybridisation.
- (iii) Paramagnetic (because of the presence of four unpaired electrons).
- (iv)  $\mu = \sqrt{n(n+2)} = \sqrt{4(4+2)} = \sqrt{24} = 4.9 \text{ BM}$

**Q. 48**  $\text{CoSO}_4\text{Cl} \cdot 5\text{NH}_3$  exists in two isomeric forms 'A' and 'B'. Isomer 'A' reacts with  $\text{AgNO}_3$  to give white precipitate, but does not react with  $\text{BaCl}_2$ . Isomer 'B' gives white precipitate with  $\text{BaCl}_2$  but does not react with  $\text{AgNO}_3$ . Answer the following questions.

- (a) Identify 'A' and 'B' and write their structural formulae.
- (b) Name the type of isomerism involved.
- (c) Give the IUPAC name of 'A' and 'B'.

**Thinking Process**

*This problem is based on chemical properties of coordination compounds, ionisation isomerism, and nomenclature of coordination compounds.*

**Ans.** 'A' gives precipitate with  $\text{AgNO}_3$ , so in it Cl is present outside the coordination sphere. 'B' gives precipitate with  $\text{BaCl}_2$ , so in it  $\text{SO}_4^{2-}$  is present outside the coordination sphere.

- (a) So, A -  $[\text{Co}(\text{NH}_3)_5 \text{SO}_4] \text{Cl}$   
 B -  $[\text{Co}(\text{NH}_3)_5 \text{Cl}] \text{SO}_4$
- (b) Ionisation isomerism (as give different ions when subjected to ionisation.)
- (c) [A], Pentaamminesulphatocobalt (III) chloride.  
 [B], Pentaamminechloridocobalt (III) sulphate.

**Q. 49** What is the relationship between observed colour of the complex and the wavelength of light absorbed by the complex?

**Ans.** When white light falls on the complex, some part of it is absorbed. Higher the crystal field splitting energy, lower will be the wavelength absorbed by the complex. The observed colour of complex is the colour generated from the wavelength left over.

e.g., if green light is absorbed, the complex appears red.

In terms of crystal field theory, suppose there is an octahedral complex with empty  $e_g$  level and unpaired electrons in the  $t_{2g}$  level in ground level. If the unpaired electron absorbs light corresponding to blue-green region, it will excite to  $e_g$  level and the complex will appear violet in colour.

In absence of ligand, crystal field splitting does not occur and the substance is colourless. e.g., anhydrous  $\text{CuSO}_4$  is white, but  $\text{CuSO}_4 \cdot 5\text{H}_2\text{O}$  is blue in colour.

**Q. 50** Why are different colours observed in octahedral and tetrahedral complexes for the same metal and same ligands?

**Ans.** Extent of splitting of  $d$ -orbitals is different in octahedral and tetrahedral field. CFSE in octahedral and tetrahedral field are closely related as.

$$\Delta_t = \left(\frac{4}{9}\right)\Delta_o$$

where,  $\Delta_t$  = crystal field splitting energy in tetrahedral field

$\Delta_o$  = crystal field splitting energy in octahedral field

Wavelength of light and CFSE are related to each other by formula

$$\Delta_o = E = \frac{hc}{\lambda}$$

$$E \propto \frac{1}{\lambda}$$

So, higher wavelength of light is absorbed in octahedral complexes than tetrahedral complexes for same metal and ligands. Thus, different colours are observed.

# 10

## Haloalkanes and Haloarenes

### Multiple Choice Questions (MCQs)

**Q. 1** The order of reactivity of following alcohols with halogen acids is .....

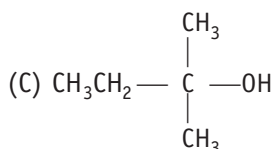
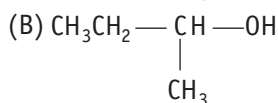
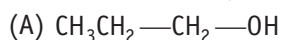

(a) (A) > (B) > (C)

(b) (C) > (B) > (A)

(c) (B) > (A) > (C)

(d) (A) > (C) > (B)

**Ans. (b)** Reaction between alcohols and halogen acid follows  $\text{S}_{\text{N}}1$  mechanism. In  $\text{S}_{\text{N}}1$  mechanism carbocations are formed as intermediates.

Let us consider the formation of carbocations with the given three alcohols.

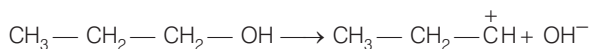

In this case,  $1^\circ$  carbocation is formed. It is least stable. So, here  $\text{S}_{\text{N}}2$  mechanism is followed. In this  $\text{S}_{\text{N}}2$  mechanism a transitory state is observed in  $\alpha$ -carbon is linked with two nucleophiles.

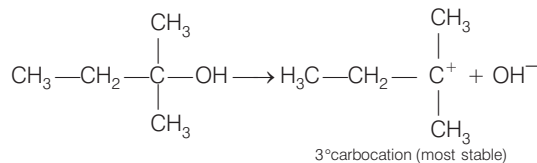
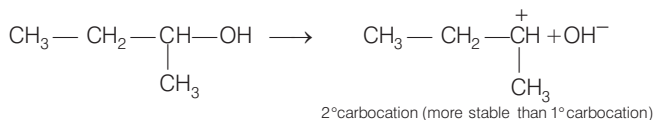

The reaction proceeded with stable carbocation. Higher the stability of carbocation, higher will be the possibilities of attack of  $X^-$  ion to the carbocation.

As, the tertiary carbocation is most stable so the possibilities of attack of  $X^-$  ion are more prominent in case of tertiary carbocations. Thus, attack of  $X^-$  ion to carbocation is proceeded with tertiary carbocation as follows

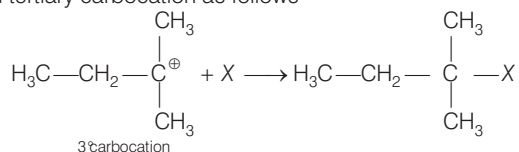

So, the correct option is (b).

**Note** Higher the stability of intermediate, higher will be the reactivity of compound and higher will be the yield of the desired product.

**Q. 2** Which of the following alcohols will yield the corresponding alkyl chloride on reaction with concentrated HCl at room temperature?

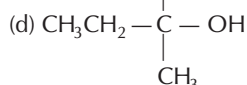
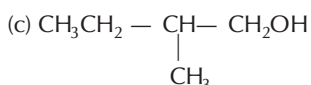
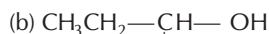

### 💡 Thinking Process

To solve this problem, students keep in mind that tertiary alcohol being most reactive react at room temperature.

**Ans. (d)** When alcohols are treated with conc., HCl at room temperature than alkyl chloride is formed. This reaction follows  $S_N1$  mechanism.  $S_N1$  mechanism completes in two steps. In first step, a carbocation is formed and this carbocation is attacked by nucleophile in second step.

The attack of nucleophile to the carbocation is possible only if the carbocation is stable. Compound present in option (d) will give tertiary carbocation in step I. Tertiary carbocation is most stable so it is further attacked by  $\text{Cl}^-$  nucleophile as follows

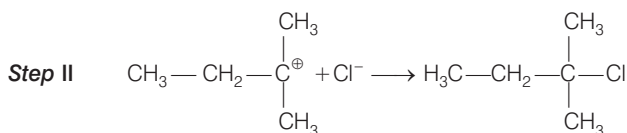
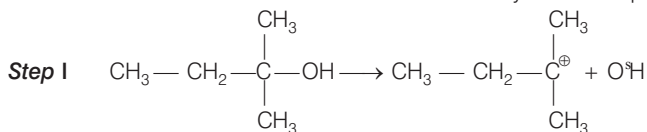

**Q. 3** Identify the compound Y in the following reaction.

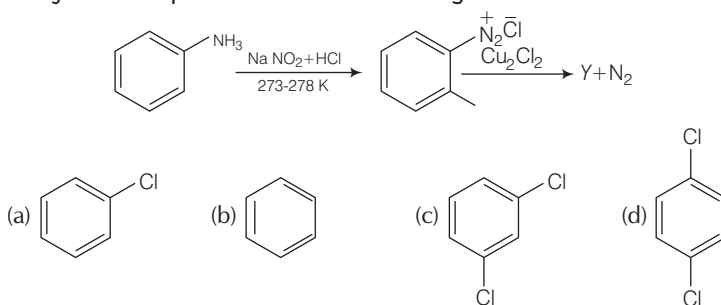

**Ans. (a)** When a primary aromatic amine, dissolved or suspended in cold aqueous mineral acid and treated with sodium nitrite, a diazonium salt is formed. When this freshly prepared diazonium salt is mixed with cuprous chloride, then diazonium group is replaced by — Cl.

Then chlorobenzene is formed which is y in this reaction.

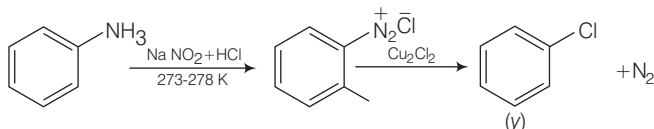

Hence, option (a) is correct.

**Q. 4** Toluene reacts with a halogen in the presence of iron (III) chloride giving ortho and para halo compounds. The reaction is

- (a) electrophilic elimination reaction
- (b) electrophilic substitution reaction
- (c) free radical addition reaction
- (d) nucleophilic substitution reaction

**Ans. (b)** Toluene reacts with a halogen in the presence of iron (III) chloride giving *ortho* and *para* halo compounds. The reaction is electrophilic substitution reaction.

It has the following mechanism

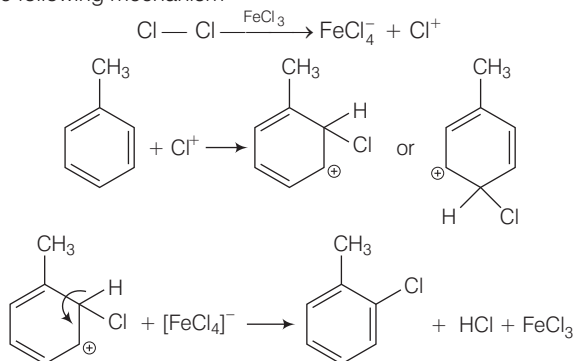

In this mechanism, electrophile  $\text{Cl}^+$  attacks to electron rich benzene ring and replaces hydrogen. So, the reaction is electrophilic substitution reaction.

**Q. 5** Which of the following is halogen exchange reaction?

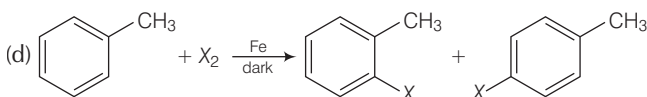
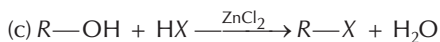
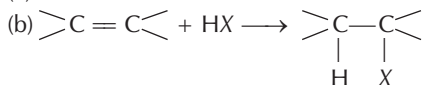
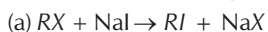

**Ans. (a)** Halogen exchange reactions are those reactions in which one halide replaces another. In option (a) halogen (-X) is replaced by iodine. This reaction is named as Finkelstein reaction.

In option (b), there is the addition of hydrogen halide on alkene.

In option (c), halogen replaces alcoholic group.

While in option (d) halogen replaces the hydrogen of benzene ring.

**Q. 6** Which reagent will you use for the following reaction?

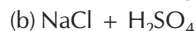
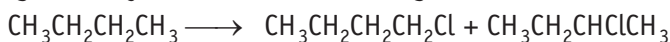

**Ans. (a)** The given reaction is a substitution reaction. It involves the replacement of  $1^\circ$  and  $2^\circ$  hydrogen of alkanes by chlorine. It occurs in presence of ultraviolet light or at high temperature.

The chlorination does not occur at room temperature in absence of light. In this reaction, light is absorbed by the chlorine molecule and activated chlorine initiates the reaction as follows

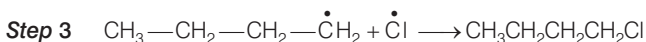
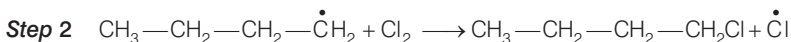
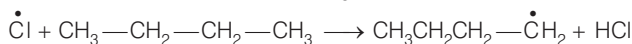

So, option (a) is the correct.

**Q. 7** Arrange the following compounds in the increasing order of their densities.

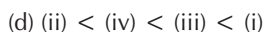
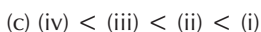
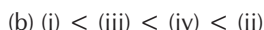
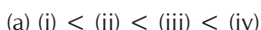
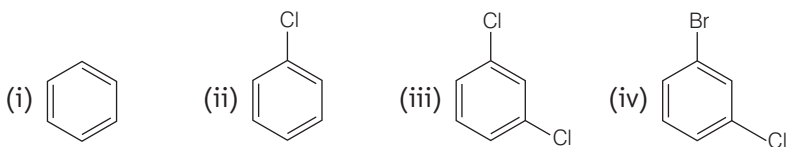

**Ans. (a)** Density is directly related to molecular mass. Higher the molecular mass, higher will be the density of the compound. Among the four given compounds, the order of molecular mass is

benzene < chlorobenzene < dichlorobenzene < bromochlorobenzene

Therefore, the increasing order of their densities are same as above.

Hence, option (a) is correct.

**Q. 8** Arrange the following compounds in increasing order of their boiling points.

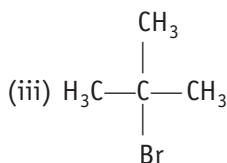
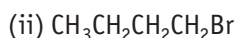
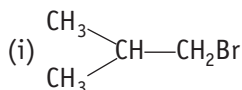

(a) (ii) < (i) < (iii)

(b) (i) < (ii) < (iii)

(c) (iii) < (i) < (ii)

(d) (iii) < (ii) < (i)

**Ans. (c)** Boiling point of a compound depends upon the surface area. Higher the surface area, higher will be the boiling point of a compound. Surface area decreases with increase in branching. If the compound has branching so its boiling point will be minimum.

Thus, the increasing order of their boiling points

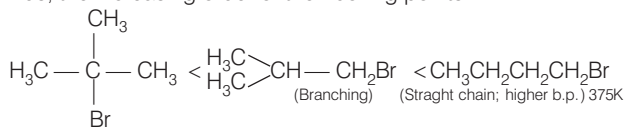

(Maximum branching; lowest b.p. 346K)

**Q. 9** In which of the following molecules carbon atom marked with asterisk (\*) is asymmetric?

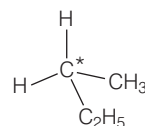
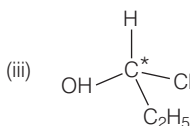
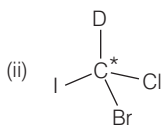
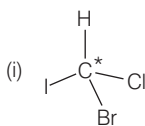

(a) (i), (ii), (iii) and (iv)

(b) (i), (ii) and (iii)

(c) (ii), (iii) and (iv)

(d) (i), (iii) and (iv)

**Ans. (b)** Asymmetric/chiral carbon atom is that in which all of its four valencies with four different groups or atoms. In compound (iv), carbon satisfies two of its valencies with two hydrogen atoms *i.e.*, similar atom.

So, it is not an asymmetric carbon atom while rest of the three molecules have asymmetric carbon as each carbon has satisfied all four valencies with four different groups or atoms.

So, the correct option is (b).



**Q. 10** Which of the following structures is enantiomeric with the molecule (A) given below?

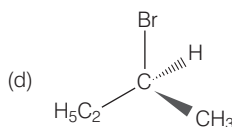
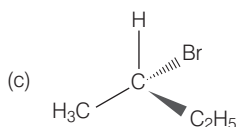
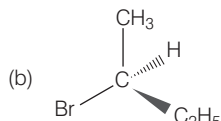
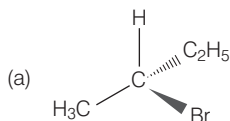
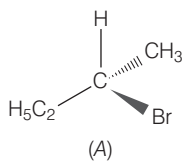

**Ans. (a)** The stereoisomers related to each other as non-superimposable mirror images are called enantiomers. Enantiomers possess identical physical properties. They only differ with respect to the rotation of plane polarised light. If one of the enantiomer is dextro rotatory, the other will be laevo rotatory.

Here, the enantiomer of molecule (A) is

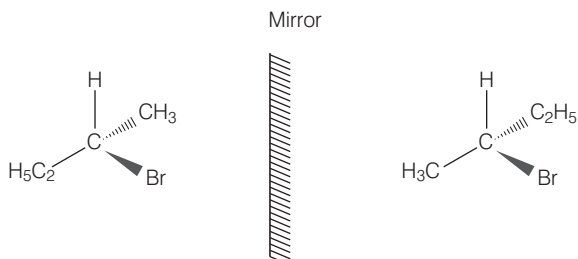

Hence, option (a) is correct.

**Q. 11** Which of the following is an example of vic-dihalide?

- (a) Dichloromethane                      (b) 1, 2-dichloroethane  
(c) Ethylidene chloride                (d) Allyl chloride

**Ans. (b)** vic-dihalides are those halides in which two halogen atoms are present on the two adjacent carbon atoms.

Write the structure of the given compound

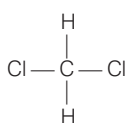

Dichloromethane

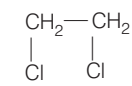

1, 2-dichloroethane

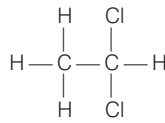

Ethylidene chloride

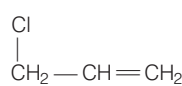

Allyl chloride

In 1, 2-dichloroethane, the two chlorine atoms are attached to two adjacent carbon atoms.

Hence, option (b) is correct.

**Q. 12** The position of Br in the compound in  $\text{CH}_3\text{CH}=\text{CH}(\text{Br})(\text{CH}_3)_2$  can be classified as .....

- (a) allyl                      (b) aryl                      (c) vinyl                      (d) secondary

**Ans. (a)** Allyl halides are those compounds in which the halogen atom is bonded to  $sp^3$  hybridised carbon atom next to carbon carbon-double bond.

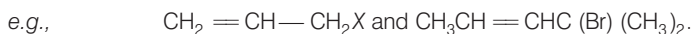

Aryl halides are the compounds in which the halogen atom is bonded to the  $sp^2$  hybridised carbon atom of an aromatic ring.

e.g.,

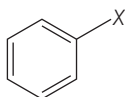

Vinyl halides are the compounds in which the halogen atom is bonded to the  $sp^2$  hybridised carbon atom of a carbon carbon double bond.



Secondary alkyl halides are the compounds in which the halogen atom is bonded to the  $sp^3$  hybridised carbon atom which is further bonded to two alkyl groups and one hydrogen atom.

e.g.,

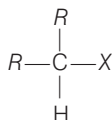

**Q. 13** Chlorobenzene is formed by reaction of chlorine with benzene in the presence of  $\text{AlCl}_3$ . Which of the following species attacks the benzene ring in this reaction?

- (a)  $\text{Cl}^-$                       (b)  $\text{Cl}^+$                       (c)  $\text{AlCl}_3$                       (d)  $[\text{AlCl}_4]^-$

**Ans. (b)** In this reaction,  $\text{AlCl}_3$  is a catalyst which activate the chlorine molecule to show heterolytic cleavage.  $\text{AlCl}_3$  is electron deficient molecule and form  $[\text{AlCl}_4]^-$  and  $\text{Cl}^+$  when reacts with  $\text{Cl}_2$ . This  $\text{Cl}^+$  electrophile attacks on electron rich benzene ring.

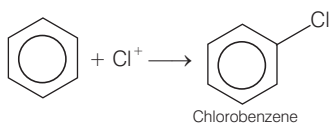
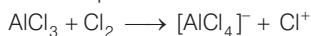

**Q. 14** Ethylidene chloride is a/an .....

- (a) *vic*-dihalide              (b) *gem*-dihalide              (c) allylic halide              (d) vinylic halide

**Ans. (b)** In *vic*-dihalides, halogen atoms are present on the adjacent carbon atoms.

In *gem*-dihalides, halogen atoms are present on the same carbon atom. They are known as alkylidene halides.

In allylic halides, halogen atom is bonded to  $sp^3$  hybridised carbon atom next to carbon-carbon double bond.

In vinylic halides, halogen atom is bonded to  $sp^2$  hybridised carbon atom of a carbon-carbon double bond.

In ethylidene chloride ( $\text{H}_3\text{C} - \text{CHCl}_2$ ) both halogen atoms are present on same carbon atom so it is *gem*-dihalide.

**Q. 15** What is 'A' in the following reaction?

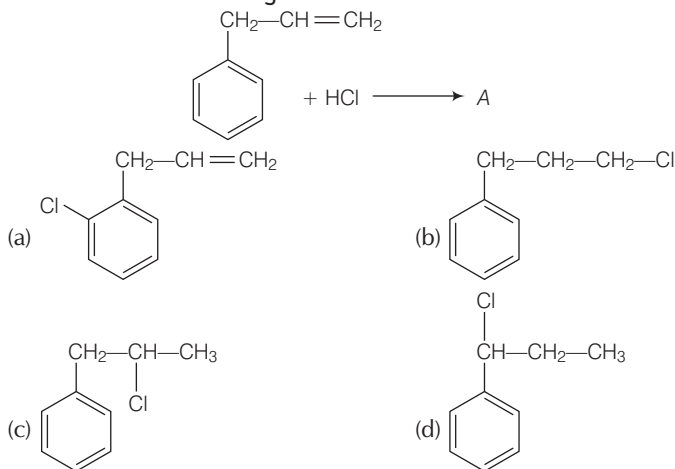

**Ans. (c)** In this reaction, addition of HCl takes place on doubly bonded carbons in accordance with Markownikoff's rule *i.e.*, addition of negative addendum will take place on that carbon which has lesser number of hydrogen.

Thus,

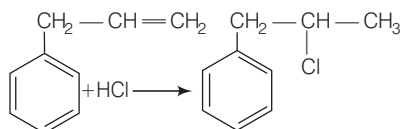

Hence, option (c) is correct.

**Q.16** A primary alkyl halide would prefer to undergo .....

- (a)  $S_N1$  reaction    (b)  $S_N2$  reaction    (c)  $\alpha$ -elimination    (d) racemisation

**Ans. (b)** A primary alkyl halide would prefer to undergo  $S_N2$  reaction.

- (a)  $S_N2$  reactions occur only if the intermediate carbocation is stable *i.e.*,  $3^\circ$  carbocation.
- (b)  $S_N2$  reactions occur if there is less steric hinderance on to the  $\alpha$ -carbon of alkyl halide. In case of primary alkyl halides, carbocation is highly unstable and steric hinderance is very less. So, primary alkyl halide would prefer to undergo  $S_N2$  reaction.
- (c) In  $\alpha$ -elimination, proton and the leaving group are present on same atom.
- (d) Racemisation is the process of conversion of enantiomer into a racemic mixture.

**Q. 17** Which of the following alkyl halides will undergo  $S_N1$  reaction most readily?

- (a)  $(\text{CH}_3)_3\text{C—F}$     (b)  $(\text{CH}_3)_3\text{C—Cl}$     (c)  $(\text{CH}_3)_3\text{C—Br}$     (d)  $(\text{CH}_3)_3\text{C—I}$

**Ans. (d)** All the given compounds are tertiary alkyl halides but the bond formed between carbon and iodine (C—I) bond is the weakest bond due to large difference in the size of carbon and iodine. So,  $(\text{CH}_3)_3\text{C—I}$  gives  $S_N1$  reaction most readily. In other words, iodine is a better leaving group.

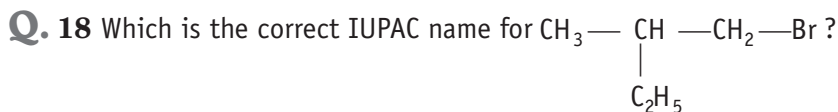

- (a) 1-bromo-2-ethylpropane                      (b) 1-bromo-2-ethyl-2-methylethane  
(c) 1-bromo-2-methylbutane                    (d) 2-methyl-1-bromobutane

**Ans. (c)** The correct IUPAC name of the given compound is

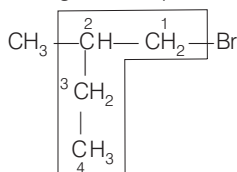

**1-bromo-2-methylbutane**



- (a) 1-bromo-1, 1-diethylmethane              (b) 3-bromopentane  
(c) 1-bromo-1-ethylpropane                  (d) 1-bromopentane

**Ans. (b)** Structure of the diethylbromomethane is given below

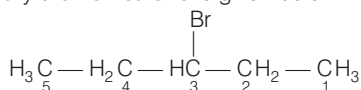

So, the IUPAC name is 3-bromopentane.

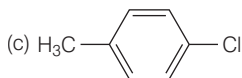
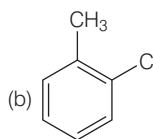
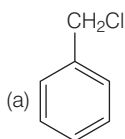
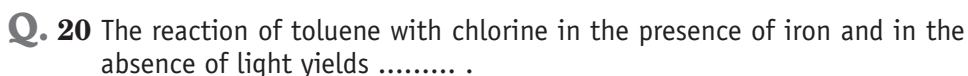

(d) Mixture of (b) and (c)

**Ans. (d)** The reaction of toluene with chlorine in the presence of iron and carried out in absence of light, so the substitution occurs in the benzene ring. The  $-\text{CH}_3$  group of toluene is *o* and *p*-directing then product is the mixture of (b) and (c) *i.e.*, *o*-chlorotoluene and *p*-chlorotoluene.

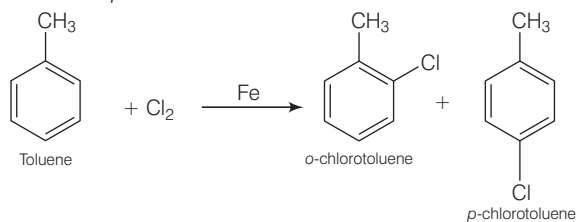

**Q. 21** Chloromethane on treatment with excess of ammonia yields mainly

- (a) N, N-dimethylmethanamine  $\left( \text{CH}_3 - \text{N} \begin{array}{l} \diagup \text{CH}_3 \\ \diagdown \text{CH}_3 \end{array} \right)$   
 (b) N-methylmethanamine  $(\text{CH}_3 - \text{NH} - \text{CH}_3)$   
 (c) methanamine  $(\text{CH}_3\text{NH}_2)$   
 (d) mixture containing all these in equal proportion

**Ans. (c)** Chloromethane on treatment with excess of ammonia yields mainly methanamine.

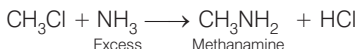

However, if the two reactants are present in the same amount, then the mixture of primary, secondary and tertiary amine is obtained.

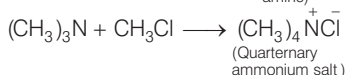
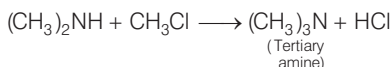
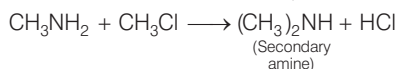
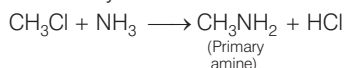

**Q. 22** Molecules whose mirror image is non-superimposable over them are known as chiral. Which of the following molecules is chiral in nature?

- (a) 2-bromobutane (b) 1-bromobutane  
 (c) 2-bromopropane (d) 2-bromopropan-2-ol

**Ans. (a)** Chiral/asymmetric carbon is that carbon in which carbon has formed four bonds with four different groups. Let see the structural formula of the given compounds.

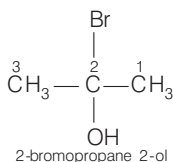
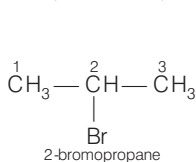
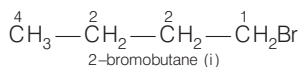
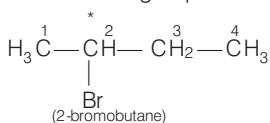

With the help of these structural formulae it is very clear that 2-bromobutane in which asterisk mark carbon atom is bonded to four different atoms or groups. So, this molecule is chiral in nature. Other molecules do not contain four different atoms or groups.

**Q. 23** Reaction of  $\text{C}_6\text{H}_5\text{CH}_2\text{Br}$  with aqueous sodium hydroxide follows .....

- (a)  $\text{S}_{\text{N}}1$  mechanism  
 (b)  $\text{S}_{\text{N}}2$  mechanism  
 (c) Any of the above two depending upon the temperature of reaction  
 (d) Saytzeff rule

**Ans. (a)**  $S_N1$  mechanism depends upon the stability of carbocation. Higher the stability of carbocation, higher will be the possibility of  $S_N1$  mechanism to take place. In the given compound,  $C_6H_5CH_2Br$  carbocation is  $C_6H_5\overset{\oplus}{C}H_2$ . This carbocation  $C_6H_5\overset{\oplus}{C}H_2$  is a stable carbocation due to resonance, therefore, it shows  $S_N1$  mechanism.

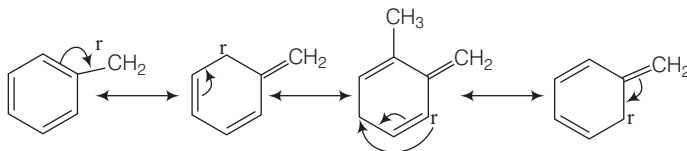

**Q. 24** Which of the carbon atoms present in the molecule given below are asymmetric?

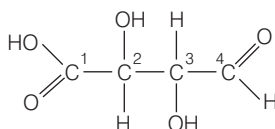

(a) 1, 2, 3, 4

(b) 2, 3

(c) 1, 4

(d) 1, 2, 3

**Ans. (b)** Carbon has four valencies. If a carbon atom satisfies all of its four valencies with four different groups then it is termed as asymmetric/chiral carbon. In the given compound, 2 and 3 carbon are bonded to four different groups, so these are asymmetric.

**Q. 25** Which of the following compounds will give racemic mixture on nucleophilic substitution by  $OH^-$  ion?

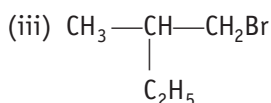
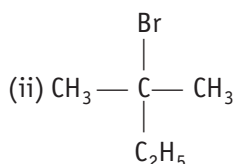
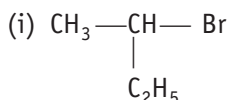

(a) (i)

(b) (i), (ii) and (iii)

(c) (ii) and (iii)

(d) (i) and (iii)

**And. (a)** A mixture containing two enantiomers in equal molar amount have zero optical rotation, as the rotation due to one isomer is cancelled by the rotation due to other isomer. Such a mixture is known as racemic mixture. All those compounds which follow  $S_N2$  mechanism during nucleophilic substitution reaction form racemic mixture.

Order of reactivity of alkyl halides towards  $S_N1$ .

and reactions as follows:

Tertiary halide; secondary halide; primary halide;  $CH_3X$ .

For  $S_N1$  reaction.

Thus,  $CH_3 - \overset{*}{\underset{\substack{| \\ C_2H_5}}{CH}} - Br$  contains a chiral carbon and gives a racemic product.

Hence, option (a) is correct.

**Directions** (Q. Nos. 26-29) In the questions 26 to 29 arrange the compounds in increasing order of rate of reaction towards nucleophilic substitution.

**Q. 26**

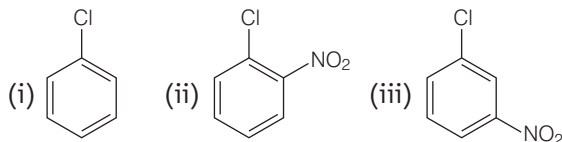

- (a) (i) < (ii) < (iii) (b) (iii) < (ii) < (i) (c) (i) < (iii) < (ii) (d) (iii) < (i) < (ii)

**Thinking Process**

To solve this question, the point keep in mind that presence of electron withdrawing group at *ortho* and *para* position to the halogen atom increases the rate of nucleophilic substitution reaction.

**Ans. (c)** The bond formed between C of benzene ring and halogen is more stable because of resonance it has partial double bond character. So, rate of reaction towards nucleophilic substitution is slow. This substitution is facilitated by the presence of electron withdrawing group at *ortho* and *para* position because electron density is high at these positions.

Compound (ii) and (iii) both has one electron withdrawing group but in compound (ii) electron withdrawing ( $\text{—NO}_2$ ) group is present at *ortho* position, so rate of reaction in compound (ii) is more than that of (iii) while (i) has no electron withdrawing group.

Hence, the correct option is (c).

**Q. 27**

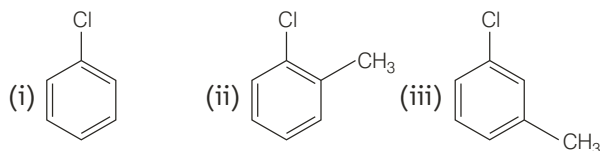

- (a) (i) < (ii) < (iii) (b) (i) < (iii) < (ii)  
(c) (iii) < (ii) < (i) (d) (ii) < (iii) < (i)

**Ans. (d)** Presence of electron releasing group at *ortho* or *para* position decreases the rate of nucleophilic substitution reaction. In compound (iii), electron releasing group is present at *meta* position w.r.t. chlorine, so the impact is less but in compound (ii) it is present at *ortho* position.

Thus, the rate of reaction towards nucleophilic substitution is least in compound (ii) and highest in compound (i) as there is no electron releasing group in this compound.

**Q. 28**

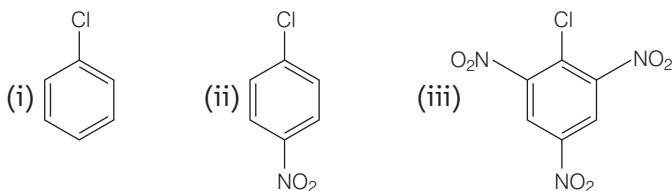

- (a) (iii) < (ii) < (i) (b) (ii) < (iii) < (i)  
(c) (i) < (iii) < (ii) (d) (i) < (ii) < (iii)

**Thinking Process**

For this questions, the point is that electron withdrawing group at *ortho* and *para* position decreases the electron density at these positions and increases the rate of reaction. Further, rate of reaction increases with increase in number of electron withdrawing group.

**Ans. (d)** Presence of electron withdrawing group at *ortho* and *para* position facilitate the nucleophilic substitution reaction and hence, enhances rate of reaction.

Compound (iii) has three electron withdrawing groups at *ortho* and *para* positions *w.r.t.* chlorine while compound (ii) has only one electron withdrawing group and there is no electron withdrawing group in compound (i). So, the increasing order of rate of reaction towards nucleophilic substitution is (i) < (ii) < (iii).

**Q. 29**

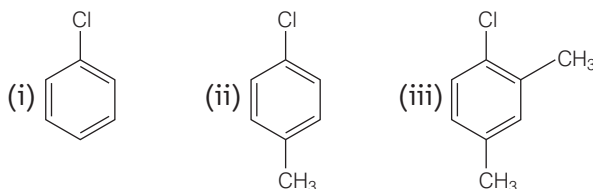

(a) (i) < (ii) < (iii) (b) (ii) < (i) < (iii) (c) (iii) < (ii) < (i) (d) (i) < (iii) < (ii)

**Ans. (c)** Presence of electron releasing group at *ortho* and *para* position *w.r.t.* to chlorine decreases the rate of nucleophilic substitution reaction. Compound (iii) has two electron releasing groups and compound (ii) has one electron releasing group *w.r.t.* chlorine while compound (i) has no electron releasing group.

So, the rate of nucleophilic substitution reaction is highest in compound (i) and order is (iii) < (ii) < (i).

**Q. 30** Which is the correct increasing order of boiling points of the following compounds?

1-iodobutane, 1-bromobutane, 1-chlorobutane, Butane

- (a) Butane < 1-chlorobutane < 1-bromobutane < 1-iodobutane  
 (b) 1-iodobutane < 1-bromobutane < 1-chlorobutane < Butane  
 (c) Butane < 1-iodobutane < 1-bromobutane < 1-chlorobutane  
 (d) Butane < 1-chlorobutane < 1-iodobutane < 1-bromobutane

**Ans. (a)** Higher the surface area, higher will be the intermolecular forces of attraction and thus boiling point too. Boiling point increases with increase in molecular mass of halogen atom for the similar type of alkyl halide. Butane has no halogen atom and rest of all three compounds are halo derivatives of butane.

Atomic mass of iodine is highest so the boiling point of 1-iodobutane is maximum among all the given compounds and hence, option (a) incorrect.

**Q. 31** Which is the correct increasing order of boiling points of the following compounds?

1-bromoethane, 1-bromopropane, 1-bromobutane, Bromobenzene

- (a) Bromobenzene < 1-bromobutane < 1-bromopropane < 1-bromoethane  
 (b) Bromobenzene < 1-bromoethane < 1-bromopropane < 1-bromobutane  
 (c) 1-bromopropane < 1-bromobutane < 1-bromoethane < Bromobenzene  
 (d) 1-bromoethane < 1-bromopropane < 1-bromobutane < Bromobenzene

**Ans. (d)** Boiling point increases with increase in size of hydrocarbon part for the same haloalkanes. All the given haloalkanes contain same halogen atom *i.e.*, bromine but the number of carbon atoms in hydrocarbon part of the molecule are increasing from ethane to benzene.

So, the boiling point is minimum for 1-bromoethane and maximum for 1-bromobenzene.



## Multiple Choice Questions (More Than One Options)

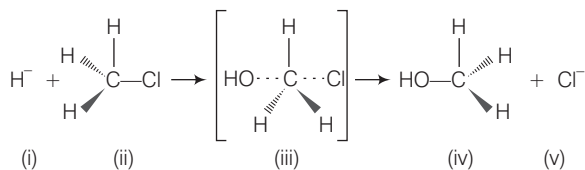

**Q. 32** Which of the statements are correct about above reaction?

- (a) (i) and (v) both are nucleophiles
- (b) In (iii) carbon atom is  $sp^3$  hybridised
- (c) In (iii) carbon atom is  $sp^2$  hybridised
- (d) (i) and (v) both are electrophiles

**Ans. (c)** In the above reaction,  $^-\text{OH}$  and  $\text{Cl}^-$  both are electron rich species as they are holding the negative charge. So, they are nucleophiles.

The above reaction show  $S_N2$  mechanism, carbon of alkyl halide is  $sp^3$  hybridised. During this mechanism, the breaking of C—X bond and formation of new bond (C—Nu) occur simultaneously through a transition state in which carbon atom is approximately  $sp^2$  hybridised.

**Q. 33** Which of the following statements are correct about this reaction?

- (a) The given reaction follows  $S_N2$  mechanism
- (b) (ii) and (iv) have opposite configuration
- (c) (ii) and (iv) have same configuration
- (d) The given reaction follows  $S_N1$  mechanism

**Ans. (a, b)**

In the given reaction, alkyl halide is primary in nature. Here, a transitory state is observed in which one bond is broken and one bond is formed synchronously *i.e.*, in one step. So, it follows  $S_N2$  mechanism.

In this mechanism, nucleophile attacks the carbon at  $180^\circ$  to the leaving group, so the reactant and product have opposite configuration.

**Q. 34** Which of the following statements are correct about the reaction intermediate?

- (a) Intermediate (iii) is unstable because in this carbon is attached to 5 atoms
- (b) Intermediate (iii) is unstable because carbon atom is  $sp^2$  hybridised
- (c) Intermediate (iii) is stable because carbon atom is  $sp^2$  hybridised
- (d) Intermediate (iii) is less stable than the reactant (ii)

**Ans. (a, d)**

For the given reaction, intermediate (iii) represent transition state, and it is highly unstable. In this transition state, carbon atom is  $sp^2$  hybridised as partially bonded to two nucleophiles so it is highly unstable and less stable than the reactant (ii). Reactant (ii), carbon atom is  $sp^3$  hybridised and more stable than intermediate (iii).

**Directions** (Q. Nos. 35-36) on the basis of the following reaction.

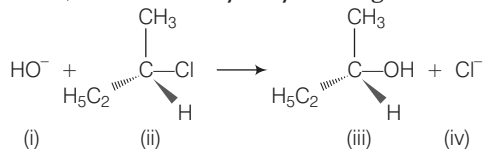

**Q. 35** Which of the following statements are correct about the mechanism of this reaction?

- (a) A carbocation will be formed as an intermediate in the reaction
- (b)  $\text{OH}^-$  will attack the substrate (ii) from one side and  $\text{Cl}^-$  will leave it simultaneously from other side
- (c) An unstable intermediate will be formed in which  $\text{OH}^-$  and  $\text{Cl}^-$  will be attached by weak bonds
- (d) Reaction proceeds through  $\text{S}_{\text{N}}1$  mechanism

**Ans. (a, d)**

The reactant involved in above reaction is secondary alkyl halide. This  $2^\circ$  alkyl halide contain bulky group that's why it follow  $\text{S}_{\text{N}}1$  mechanism instead of  $\text{S}_{\text{N}}2$  mechanism. In  $\text{S}_{\text{N}}1$  mechanism, a stable carbocation will be formed as an intermediate. It is further attacked by  $\text{HO}^-$  nucleophile.

**Q. 36** Which of the following statements are correct about the kinetics of this reaction?

- (a) The rate of reaction depends on the concentration of only (ii)
- (b) The rate of reaction depends on concentration of both (i) and (ii)
- (c) Molecularity of reaction is one
- (d) Molecularity of reaction is two

**Ans. (a c)**

The above reaction follows  $\text{S}_{\text{N}}1$  mechanism. In  $\text{S}_{\text{N}}1$  mechanism formation of carbocation is a slow step. So, the rate of reaction depends upon the concentration of (ii). So, the rate of reaction depends upon the concentration of only (ii) therefore, molecularity of reaction is one.

**Q. 37** Haloalkanes contain halogen atom(s) attached to the  $\text{sp}^3$  hybridised carbon atom of an alkyl group. Identify haloalkane from the following compounds.

- (a) 2-bromopentane
- (b) Vinyl chloride (chloroethene)
- (c) 2-chloroacetophenone
- (d) Trichloromethane

**Ans. (a, d)**

In the structure of 2-bromopentane  $(\text{CH}_3-\text{CH}-\text{CH}_2-\text{CH}_2-\text{CH}_3)$  and trichloromethane  $\left( \begin{array}{c} \text{Cl} \\ | \\ \text{Cl}-\text{C}-\text{H} \\ | \\ \text{Cl} \end{array} \right)$ , halogen atoms are attached to the  $\text{sp}^3$  hybridised carbon atom of an alkyl group.

**Q. 38** Ethylene chloride and ethylidene chloride are isomers. Identify the correct statements.

- (a) Both the compounds form same product on treatment with alcoholic KOH  
 (b) Both the compounds form same product on treatment with aq. NaOH  
 (c) Both the compounds form same product on reduction  
 (d) Both the compounds are optically active

**Ans. (a, c)**

(a) Ethylene chloride and ethylidene chloride on treatment with alc. KOH show elimination reaction and ethyne as the product.

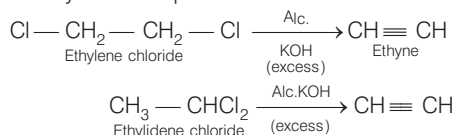

(b) Both these compounds form different products on treatment with aq. NaOH.

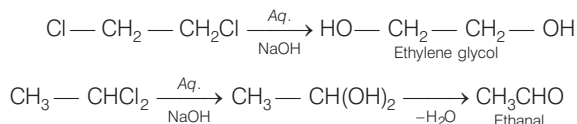

(c) Both these compounds form same products on reduction.

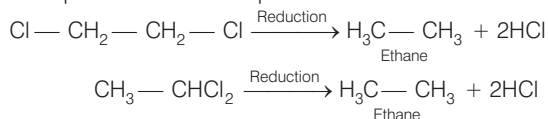

(d) Both these compounds are optically inactive.

**Q. 39** Which of the following compounds are gem-dihalides?

- (a) Ethylidene chloride                      (b) Ethylene dichloride  
 (c) Methylene chloride                      (d) Benzyl chloride

**Ans. (a, c)**

*Gem*-dihalides are those dihalides in which two halogen atoms are bonded to the same carbon atom.

Write the structure of the given compounds.

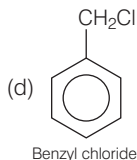
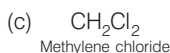
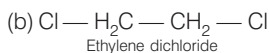
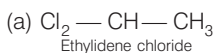

So, in option (a) and (c) two halogen atoms are present on the same carbon atom and they are termed as *gem*-dihalides.

**Q. 40** Which of the following are secondary bromides?

- (a)  $(\text{CH}_3)_2\text{CHBr}$                               (b)  $(\text{CH}_3)_3\text{CCH}_2\text{Br}$   
 (c)  $\text{CH}_3\text{CH}(\text{Br})\text{CH}_2\text{CH}_3$                       (d)  $(\text{CH}_3)_2\text{CBrCH}_2\text{CH}_3$

Ans. (a, c)

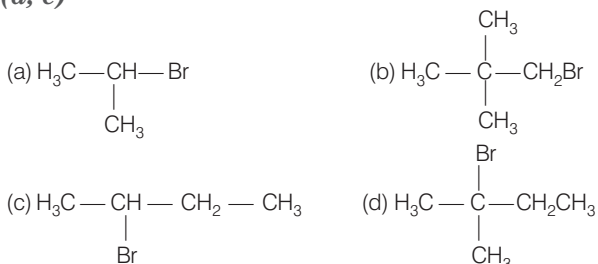

Secondary bromides are those compounds in which  $\alpha$ -carbon (*i.e.*, carbon bonded to bromine) is further bonded to two alkyl groups.

In compound (a) and (c)  $\alpha$ -carbon is bonded to two alkyl groups that's why it is secondary bromide but in compound (b) it is bonded to one alkyl group and it is primary bromide. In compound (d) it is bonded to three alkyl groups and it is tertiary alkyl halide.

**Q. 41** Which of the following compounds can be classified as aryl halides?

- (a)  $p\text{-ClC}_6\text{H}_4\text{CH}_2\text{CH}(\text{CH}_3)_2$       (b)  $p\text{-CH}_3\text{CHCl}(\text{C}_6\text{H}_4)\text{CH}_2\text{CH}_3$   
 (c)  $o\text{-BrH}_2\text{C}-\text{C}_6\text{H}_4\text{CH}(\text{CH}_3)\text{CH}_2\text{CH}_3$       (d)  $\text{C}_6\text{H}_5-\text{Cl}$

**Thinking Process**

To solve this question, point to the mind that

Aryl halides represent these compounds in which the halogen atom is bonded to the  $sp^2$  hybridised carbon atom of an aromatic ring.

Ans. (a, d)

Write the structure of the given compounds.

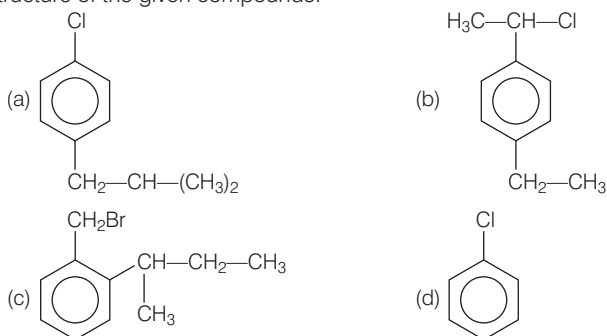

So, from the above structure it is very clear that in compound (a) and compound (d), halogen atom is directly bonded to aromatic ring *therefore* these compounds are classified as aryl halides

**Q. 42** Alkyl halides are prepared from alcohols by treating with

- (a)  $\text{HCl} + \text{ZnCl}_2$       (b)  $\text{Red P} + \text{Br}_2$   
 (c)  $\text{H}_2\text{SO}_4 + \text{KI}$       (d) All of these

Ans. (a, b)

(a) Alcohol when treated with  $\text{HCl} + \text{ZnCl}_2$  then alkyl halide is formed.

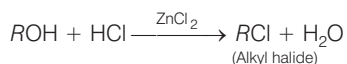

(b) Alcohol when treated with red P and  $X_2$  then product is alkyl halide.

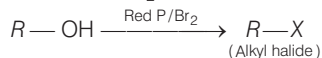

(c) Alcohols when treated with  $H_2SO_4$  and KI then  $H_2SO_4$  oxidises KI to  $I_2$  and does not produce HI. therefore, alkyl iodide does not form if the alcohols are treated with  $H_2SO_4 + KI$ .

**Q. 43** Alkyl fluorides are synthesised by alkyl chloride/bromide in presence of ..... or .....

- (a)  $CaF_2$  (b)  $CoF_2$   
(c)  $Hg_2F_2$  (d) NaF

**Ans. (b, c)**

Alkyl fluorides are synthesised by alkyl chloride/bromide in presence of  $CoF_2$  or  $Hg_2F_2$ . Only transition metal fluorides react with alkyl chloride/bromide to form alkyl fluorides. Alkali metal fluoride such as NaF and alkaline earth metal fluoride such as  $CaF_2$  do not react to form fluorides.

**Note** The reaction is termed as Swarts reaction in which alkyl fluorides are synthesised by heating an alkyl chloride/bromide in the presence of AgF,  $Hg_2F_2$ ,  $CoF_2$ .

**Q. 44** Aryl chlorides and bromides can be easily prepared by electrophilic substitution of arenes with chlorine and bromine respectively in the presence of Lewis acid catalysts. But why does preparation of aryl iodides requires presence of an oxidising agent?

**Ans.** Iodination reactions are reversible in nature.

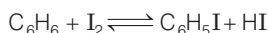

In this above reaction, hydrogen iodide is formed apart from the required product. It has to be removed from the reaction mixture in order to prevent the backward reaction.

To carry out the reaction in the forward direction, HI formed during the reaction is removed by oxidation using oxidising agent. Such as  $HIO_3$  or  $HNO_3$ . The reaction is as follow

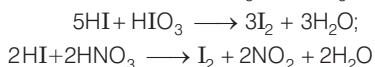

By using a suitable oxidising agent HI is oxidised to give  $I_2$ .

**Q. 45** Out of *o*- and *p*-dibromobenzene which one has higher melting point and why?

**Ans.** *p*-dibromobenzene has higher melting point than its *o*-isomer due to symmetry. Due to symmetry, *p*- isomer fits in the crystal lattice better than the *o*-isomer. Hence, *p*-dibromobenzene has higher melting point.

**Q. 46** Which of the compounds will react faster in  $S_N1$  reaction with the  $^-OH$  ion?

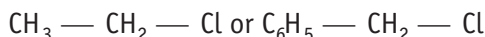

**Ans.**  $S_N1$  mechanism depends upon the stability of carbocation that is formed as intermediate in the mechanism.

$CH_6 - CH_2 - Cl$  will form  $C_6H_5^+CH_2$  carbocation as intermediate.

This carbocation is resonance stabilised and will react faster in  $S_N1$  reaction.

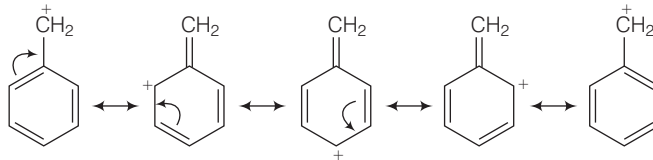

While carbocation formed in  $\text{CH}_3\text{CH}_2\text{Cl}$  is  $\text{CH}_3\overset{+}{\text{C}}\text{H}_2$ . This carbocation is highly unstable and not give  $S_N1$  reaction with  $^-\text{OH}$  ion.

**Q. 47** Why iodoform has appreciable antiseptic property?

**Ans.** Iodoform liberate  $\text{I}_2$  when it comes in contact with skin. Antiseptic property of iodine is due to the liberation of  $\text{I}_2$  not because of iodoform itself.

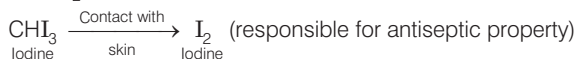

**Q. 48** Haloarenes are less reactive than haloalkanes and haloalkenes. Explain.

**Ans.** Due to resonance, C—X bond in haloarenes and haloalkenes have some double bond character. This partial double bond character of C—X bond strengthen the bond. So, haloarenes and haloalkenes are less reactive than haloalkanes.

Lets see the resonating structure of the haloarenes and haloalkenes

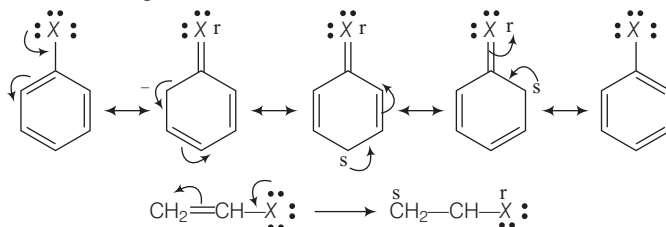

Now, more the number of resonating structure higher will be the stability of the compound and lesser will be the reactivity. In haloarenes, more resonating structures are observed than the haloalkenes. So, haloarenes are less reactive than haloalkenes. In haloalkanes, this C—X bond is purely single bond.

**Q. 49** Discuss the role of Lewis acids in the preparation of aryl bromides and chlorides in the dark.

**Ans.** Lewis acids are electron deficient species. They are responsible for, inducing heterolytic fission in halogen molecule.

Role of Lewis acid is to produce an electrophile. The electrophile produce will attack on electron rich benzene ring to produce aryl bromides and chlorides.

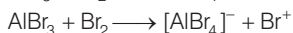
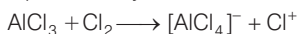

This electrophile will further attack on benzene.

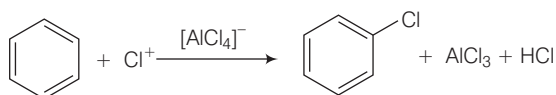

**Q. 50** Which of the following compounds (i) and (ii) will not react with a mixture of NaBr and H<sub>2</sub>SO<sub>4</sub>. Explain why?

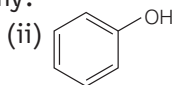
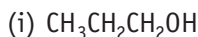

**Ans.** Partial double bond character of a bond increases the strength of the bond and hence, decreases the stability. Phenol will not react with a mixture of NaBr and H<sub>2</sub>SO<sub>4</sub> because it is resonance stabilised. Due to resonance, partial double bond character arises in C—O bond of phenol and it becomes more stable than alcohol. (CH<sub>3</sub>CH<sub>2</sub>CH<sub>2</sub>OH).

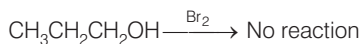
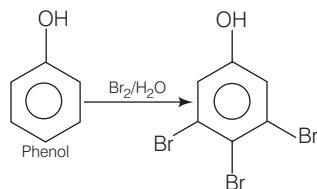
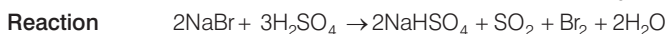

**Q. 51** Which of the products will be major product in the reaction given below? Explain

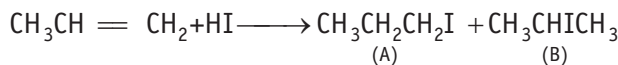

### 💡 Thinking Process

The reaction is based on the Markownikoff's rule.

Markownikoff's rule states that the negative part of adding molecule get attached that carbon atom of double bond which carries lesser number of hydrogen atom.

**Ans.** CH<sub>3</sub>CHICH<sub>3</sub> is the major product of the reaction. The mechanism of the reaction is as follows

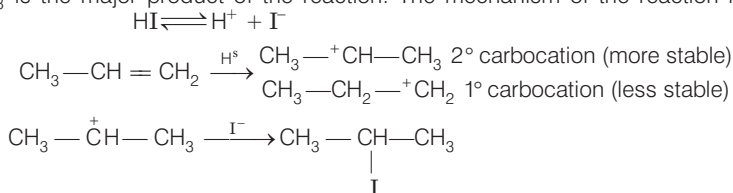

**Q. 52** Why is the solubility of haloalkanes in water very low?

**Ans.** Haloalkanes are slightly soluble in water. For the solubility to haloalkane in water, energy is required to overcome the attractions between its own molecules and to break the bonds between water molecules.

Less energy is released when new attractions are set up between the haloalkanes and the water molecules as these are not as strong as the original hydrogen bonds in water.

**Q. 53** Draw other resonance structures related to the following structure and find out whether the functional group present in the molecule is *ortho*, *para* directing or *meta* directing.



**Ans.** Resonance in halobenzene

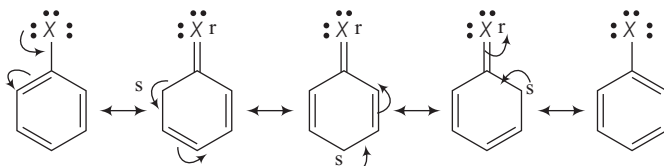

From the above resonating structure it is very clear that electron density is rich at *ortho* and *para* position. Therefore, it is *ortho* and *para* directing not *meta* directing.

**Q. 54** Classify the following compounds as primary, secondary and tertiary halides.

(a) 1-bromobut-2-ene

(b) 4-bromopent-2-ene

(c) 2-bromo-2-methylpropane

**Ans.** The structural formula of the given compounds are

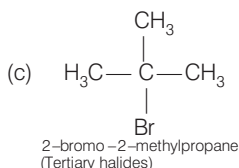
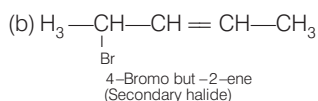
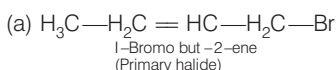

In compound (i), carbon atom to which halogen is bonded, further bonded to two hydrogens and one carbon of hydrocarbon chain. So, it is primary halide.

In compound (ii),  $\alpha$ -carbon is bonded with one hydrogen and two carbons of two hydrocarbons chain. So, it is secondary halide.

In compound (iii)  $\alpha$ -carbon is bonded to three alkyl group, so it is tertiary halide.

**Q. 55** Compound 'A' with molecular formula  $\text{C}_4\text{H}_9\text{Br}$  is treated with aq. KOH solution. The rate of this reaction depends upon the concentration of the compound 'A' only. When another optically active isomer 'B' of this compound was treated with aq. KOH solution, the rate of reaction was found to be dependent on concentration of compound and KOH both.

(i) Write down the structural formula of both compounds 'A' and 'B'.

(ii) Out of these two compounds, which one will be converted to the product with inverted configuration.

**Ans.** (i) As the rate of reaction depends upon the concentration of compound 'A' ( $\text{C}_4\text{H}_9\text{Br}$ ) only therefore, the reaction is proceeded by  $\text{S}_{\text{N}}1$  mechanism and the given compound will be tertiary alkyl halide *i.e.*, 2-bromo-2-methylpropane and the structure is as follow

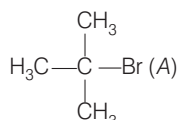



Optically active isomer of (A) is 2-bromobutane (B) and its structural formula is

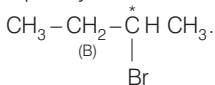

- (ii) As compound (B) is optically active therefore, compound (B) must be 2-bromobutane. Since, the rate of reaction of compound (B) depends both upon the concentration of compound (B) and KOH, hence, the reaction follows  $S_N2$  mechanism. In  $S_N2$  reaction, nucleophile attack from the back side, therefore, the product of hydrolysis will have opposite configuration

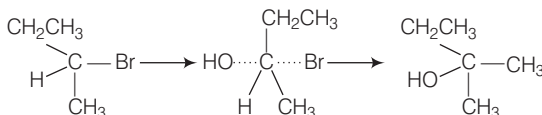

**Q. 56** Write the structures and names of the compounds formed when compound 'A' with molecular formula  $C_7H_8$  is treated with  $Cl_2$  in the presence of  $FeCl_3$ .

**Ans.** When compound 'A' with molecular formula,  $C_7H_8$  is treated with  $Cl_2$  in the presence of  $FeCl_3$  *o*-chlorotoluene or *p*-chlorotoluene will be formed as the compound A with molecular formula  $C_7H_8$  is toluene.

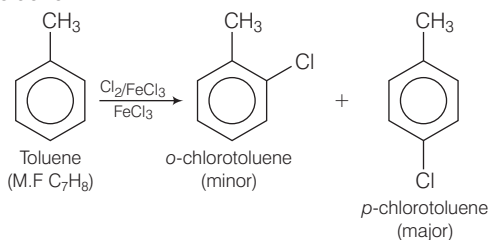

**Mechanism**  $Cl-Cl + FeCl_3 \rightarrow [FeCl_4]^- + Cl^+$

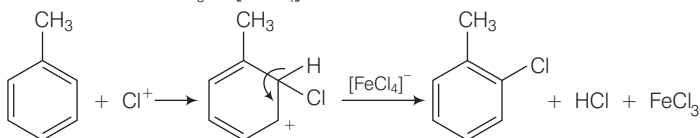

**Q. 57** Identify the products A and B formed in the following reaction

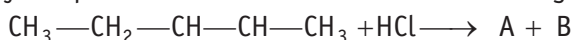

**Ans.** In the given reaction, addition occurs and the following two products (A and B) are possible

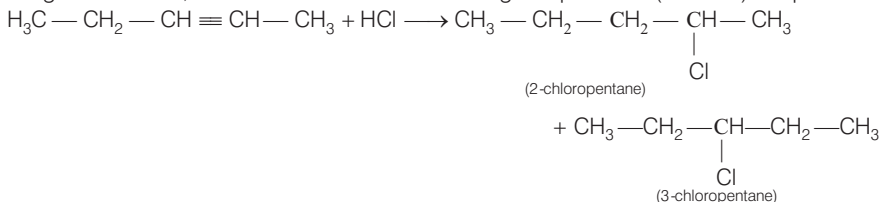

Further the carbocation formed from compound (A) is slightly less stable than carbocation leading to the formation of compound (B) therefore the amount of 2-chloropentane (B) will be slightly more than that of 3-chloropentane (A).

**Q. 58** Which of the following compounds will have the highest melting point and why?

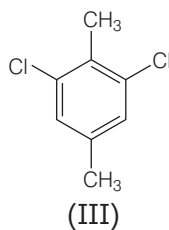
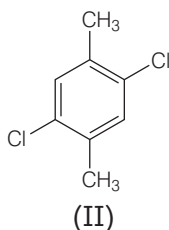
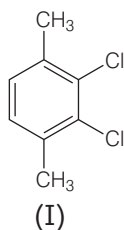

**Ans.** In compound (II), both the  $\text{CH}_3$  groups and Cl atoms at *para*-position to each other. Therefore, compound (II) is more symmetrical and it fits in the crystal lattice better than the other two isomers and hence it has the highest melting point than the others.

**Q. 59** Write down the structure and IUPAC name for neo-pentylbromide.

**Ans.** The structure of *neo*-pentylbromide is

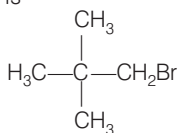

IUPAC name  $\Rightarrow$  1-bromo-2,2-dimethylpropane

Common name  $\Rightarrow$  *neo*-pentylbromide

**Q. 60** A hydrocarbon of molecular mass  $72 \text{ g mol}^{-1}$  gives a single monochloro derivative and two dichloro derivatives on photo chlorination. Give the structure of the hydrocarbon.

**Ans.** Since, the molar mass of hydrocarbon is  $72 \text{ g mol}^{-1}$  that's why the hydrocarbon is  $\text{C}_5\text{H}_{12}$  *i.e.*, pentane.

On photo chlorination, it gives monochloro derivatives so, all the hydrogen atoms must be equivalent and the structure of the compound will be

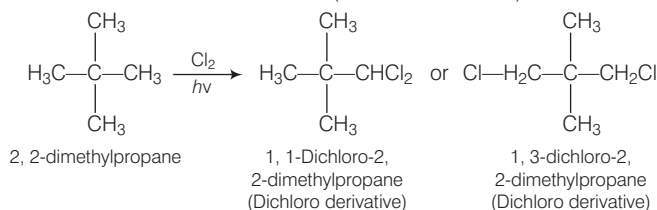
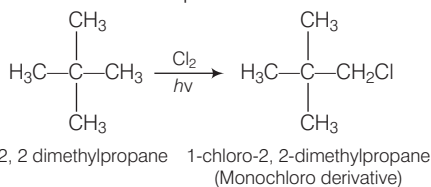

**Q. 61** Name of the alkene which will yield/chloro 1-methylcyclohexane by its reaction with HCl. Write the reactions involved.

**Ans.** Two alkenes are possible

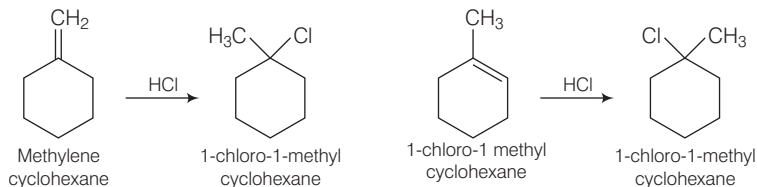

Addition takes place in accordance with Markownikoff's rule *i.e.*, negative part of the adding molecule will get attached to that carbon which has lesser number of hydrogen atom.

**Q. 62** Which of the following haloalkanes reacts with aqueous KOH most easily? Explain giving reason.

(i) 1-bromobutane

(ii) 2-bromobutane

(iii) 2-bromo-2-methylpropane

(iv) 2-chlorobutane

**Ans.** 2-bromo-2-methylpropane (iii), is a tertiary alkyl halide and it will form a stable carbocation on ionisation.

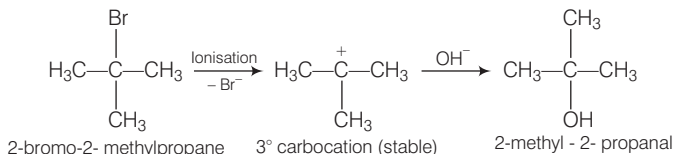

1-bromobutane is primary alkyl halide whereas 2-bromobutane and 2-chlorobutane is secondary alkyl halide.

**Q. 63** Why can aryl halides not be prepared by reaction of phenol with HCl in the presence of  $\text{ZnCl}_2$ ?

**Ans.** Due to resonance in phenol, C—O bond of phenol has some partial double bond character. Partial double bond character strengthens the bond. So, it is difficult to break this C—O bond of phenol while the C—O bond of alcohol is purely single bond and comparatively weaker bond.

So alkyl halides can be prepared by the reaction of alcohols with HCl in the presence of  $\text{ZnCl}_2$  while aryl halides can not be prepared by reaction of phenol with HCl in the presence of  $\text{ZnCl}_2$ .

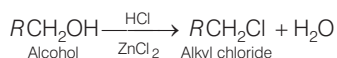
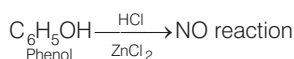

**Q. 64** Which of the following compounds would undergo  $\text{S}_{\text{N}}1$  reaction faster and why?

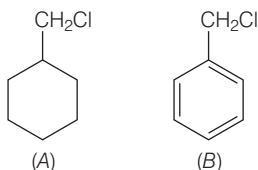

**Ans.** Compound (B) will give  $S_N1$  reaction faster than compound (A) because  $S_N1$  reaction depends upon the stability of carbocation. Benzyl chloride on ionisation gives  $C_6H_5\overset{+}{C}H_2$  carbocation which is resonance stabilised while the carbocation obtained from compound (A) is not stabilised by resonance.

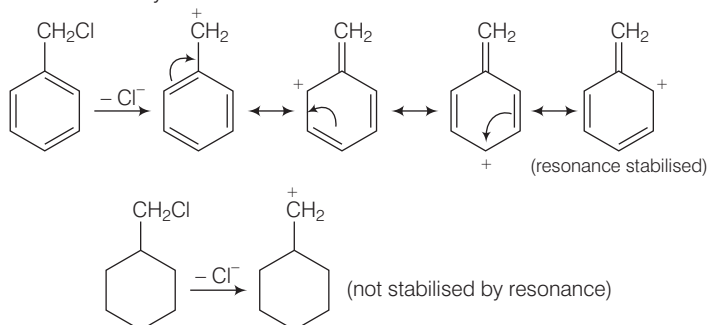

**Q. 65** Allyl chloride is hydrolysed more readily than *n*-propyl chloride. Why?

**Ans.** As we know that  $S_N1$  mechanism depends upon the stability of carbocation. Allyl chloride on hydrolysis gives resonance stabilised carbocation while no resonance is observed in the carbocation formed by *n*-propyl chloride.

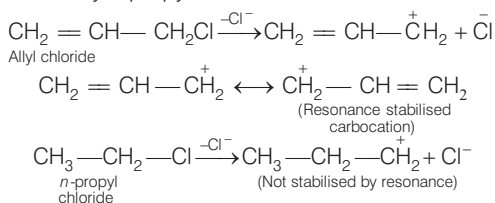

Hence, allyl chloride undergoes hydrolysis much faster than *n*-propyl chloride.

**Q. 66** Why is it necessary to avoid even traces of moisture during the use of a Grignard reagent?

**Ans.** Grignard reagents are highly reactive and react with water to give corresponding hydrocarbons.

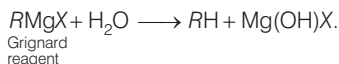

**Q. 67** How do polar solvents help in the first step in  $S_N1$  mechanism?

**Ans.** Polar solvents help in the first step in  $S_N1$  mechanism because leaving group and carbocation both are stabilised by polar solvent. Polarity of a solvent depends upon the value of dielectric constant. Higher the value of dielectric constant, higher will be the polarity of the solvent, faster will be the rate of  $S_N1$  mechanism. These polar solvents can work as a nucleophile and stabilise the carbocation as follows

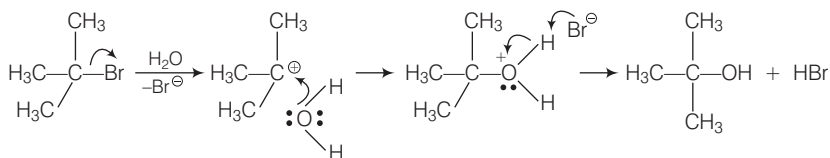

**Q. 68** Write a test to detect the presence of double bond in a molecule.

**Ans.** Presence of double bond in a molecule is detected by following two methods:

- (i) **Br<sub>2</sub> in CCl<sub>4</sub> test** When Br<sub>2</sub> / CCl<sub>4</sub> is added unsaturated compound then orange colour of bromine disappears and dibromoderivative is formed. (colourless).

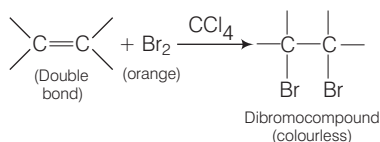

- (ii) **Bayer's test** When alkaline solution of KMnO<sub>4</sub> is added to the solution of unsaturated compound then its pink colour disappears due to the formation of dihydroxy derivative.

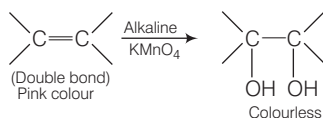

**Q. 69** Diphenyls are potential threat to the environment. How are these produced from aryl halides?

**Ans.** In environment, diphenyl is formed during the incomplete combustion of mineral oil and coal. It is present in the exhaust gases of vehicles and in exhaust air from residential and industrial heating devices.

Acute exposure to high levels of biphenyl has been observed to cause eye and skin irritation and toxic effects on the liver, kidneys and central /peripheral nervous system. Kidneys of animals are also affected due to the ingestion of biphenyls. In rats, fetotoxicity has been observed if they are exposed to high levels of biphenyl.

Preparation of diphenyls from aryl halides

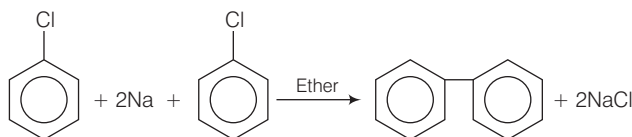

Aryl halides, when treated with sodium in dry ether give diphenyl. This reaction is named as Fittig reaction.

**Q. 70** What are the IUPAC names of the insecticide DDT and benzene hexachloride? Why is their use banned in India and other countries?

**Ans.** The IUPAC name of DDT is 2,2-bis (4-chlorophenyl)-1,1,1-trichloroethane and that of benzene hexachloride is 1,2,3,4,5,6-hexachlorocyclohexane.

They are banned in india because they are non-biodegradable. Instead, they get deposited and stored in fatty tissues. If this ingestion continues at a steady rate, DDT builds up within the animal over time. This will affects the reproductive system of animals.

If animals including humans are exposed to high levels of benzene hexachloride then it may cause acute poisoning. Apart from that this BHC may affect liver functioning in humans.

**Q. 71** Elimination reactions (especially  $\beta$  – elimination) are as common as the nucleophilic substitution reaction in case of alkyl halides. Specify the reagents used in both cases.

**Ans.** Elimination reactions are as common as the nucleophilic substitution reaction in case of alkyl halides as two reactions occur simultaneously. Generally, at lower temperature and by using weaker base nucleophilic substitution reaction occur while at higher temperature and by using a stronger base elimination reactions (especially  $\beta$  – elimination) take place. e.g., If ethyl bromide is treated with aq. KOH, at low temperature it gives ethanol while if it is treated with alc, KOH at high temperature then it gives ethene.

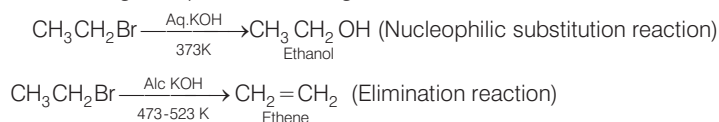

**Q. 72** How will you obtain monobromobenzene from aniline?

**Ans.** When aniline, dissolved or suspended in cold aqueous mineral acid, is treated with sodium nitrite, a diazonium salt is formed. This diazo salt on treatment with cuprous bromide gives monobromobenzene.

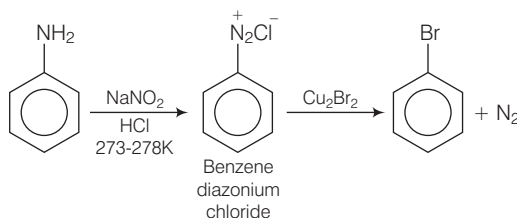

This reaction is named as Sandmeyer's reaction. If benzene diazonium chloride is treated with copper in HBr then the product formed is bromobenzene. This reaction is known as Gattermann reaction.

**Q. 73** Aryl halides are extremely less reactive towards nucleophilic substitution. Predict and explain the order of reactivity of the following compounds towards nucleophilic substitution.

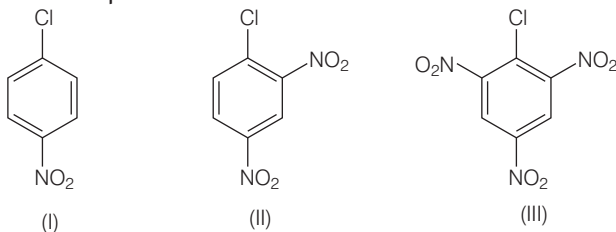

**Ans.** Aryl halides are less reactive towards nucleophilic substitution reaction. Presence of electron withdrawing group at *ortho* and *para* position increases the stability of intermediates and hence increases the reactivity of aryl halides towards nucleophilic substitution reaction.

Now, more the number of EWG at *ortho* and *para* position, higher will be the reactivity of aryl halide. Compound (III) has three EWG so, it is most reactive and compound (I) has only one EWG so, it is least reactive. So, the order of reactivity is (I) < (II) < (III)

**Q. 74** *tert*-Butylbromide reacts with aq. NaOH by  $S_N1$  mechanism while *n*-butylbromide reacts by  $S_N2$  mechanism. Why?

**Ans.** *tert.* butyl bromide reacts with aq. NaOH as follows

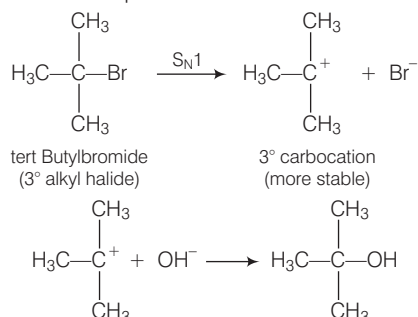

*tert.* butyl bromide when treated with aq. NaOH, it forms *tert.* carbocation which is more stable intermediate. This intermediate is further attacked by  $\text{OH}^-$  ion.

As *tert.* carbocation is highly stable so *tert* butylbromide follow  $S_N1$  mechanism.

In case of *n*-butylbromide, primary carbocation is formed which is least stable so, it does not follow  $S_N1$  mechanism. Here, steric hindrance is very less so, it follow  $S_N2$  mechanism. In  $S_N2$  mechanism,  $\text{OH}^-$  will attack from backside and a transition state is formed.

The leaving group is then pushed off the opposite side and the product is formed.

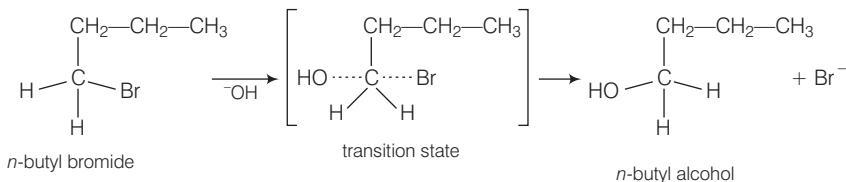

**Q. 75** Predict the major product formed when HCl is added to isobutylene, Explain the mechanism involved.

**Ans.** Reaction between the isobutylene added to HCl

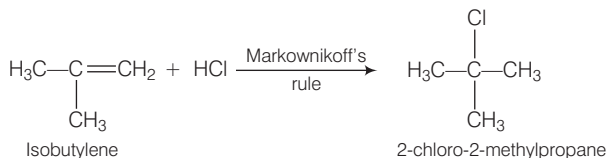

Electrophilic addition reaction takes place in accordance with Markownikoff's rule.

**Mechanism**

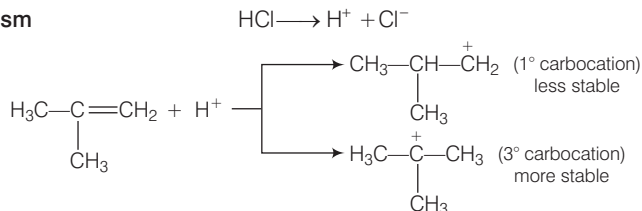

We know that 3° carbocation is more stable than 1° carbocation because in further step 3° carbocation is further attacked by  $\text{Cl}^-$  ion.

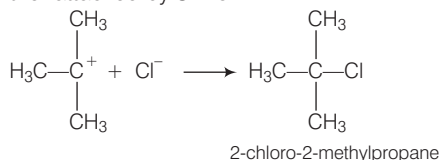

**Q. 76** Discuss the nature of C—X bond in the haloarenes.

**Ans.** In haloarenes, carbon of benzene is bonded to halogen. Electronegativity of halogen is more than that of  $sp^2$  hybridised carbon of benzene ring. So, C—X bond is a polar bond. Apart from this, lone pair of electrons of halogen atom are involved in resonance with benzene ring. So, this C—X bond has acquire partial bond character.

This C—X bond of haloarenes is less polar than C—X bond of haloalkanes. This is supported by the fact that dipole moment of chlorobenzene ( $\mu = 1.69$  D) is little lower than that of  $\text{CH}_3\text{Cl}$  ( $\mu = 1.83$  D)

**Q. 77** How can you obtain iodoethane from ethanol when no other iodine containing reagent except NaI is available in the laboratory?

**Ans.** Ethanol is treated with red phosphorous and bromine mixture and the product formed will be bromoethane. The bromoethane so formed is then treated with NaI to give iodoethane.

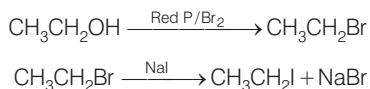

This reaction is known as Finkelstein reaction.

**Q. 78** Cyanide ion acts as an ambident nucleophile. From which end it acts as a stronger nucleophile in aqueous medium? Give reason for your answer.

**Ans.** Cyanide ion ( $:\text{C} \equiv \text{N}$ ) is an ambident nucleophile because it can react either through carbon or through nitrogen. Since, C—C bond is stronger than C—N bond so, cyanide ion will mainly attack through carbon to form alkyl cyanide.

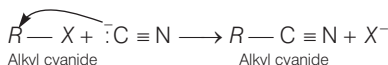

## Matching The Columns

**Q. 79** Match the the compounds given in Column I with the effect given in Column II.

Column I	Column II
A. Chloramphenicol	1. Malaria
B. Thyroxine	2. Anaesthetic
C. Chloroquine	3. Typhoid fever
D. Chloroform	4. Goiter
	5. Blood substituent



**Ans. A.** → (3)    **B.** → (4)    **C.** → (1)    **D.** → (2)

- A. Chloramphenicol is a broadspectrum antibiotic. It is used in the treatment of typhoid fever.
- B. Thyroxine is a hormone secreted by thyroid gland. Excessive secretion of thyroxine in the body is known as hyperthyroidism. Most patient with hyper thyroidism have an enlarged thyroid gland *i.e.*, goitre.
- C. Chloroquine prevents the development of malaria parasite *plasmodium vivax* in the blood.
- D. IUPAC name of chloroform is trichloromethane with formula  $\text{CHCl}_3$ . It is a colourless, volatile, sweet-smelling liquid. Its vapours depresses the central nervous system and used as an anaesthetic.

**Q. 80** Match the items of Column I and Colum II.

Column I	Column II
A. $\text{S}_{\text{N}}1$ reaction	1. <i>vic</i> -dibromides
B. Chemicals in fire extinguisher	2. <i>gem</i> -dihalides
C. Bromination of alkenes	3. Racemisation
D. Alkylidene halides	4. Saytzeff rule
E. Elimination of HX from alkylhalide	5. Chlorobromocarbons

**Ans. A.** → (3)    **B.** → (5)    **C.** → (1)    **D.** → (2)    **E.** → (4)

- A. A mixture containing two enantiomers in equal proportions will have zero optical rotation, such a mixture is known as racemic mixture. The process of conversion of enantiomer into a racemic mixture is known as racemisation. If an alkyl halide follows  $\text{S}_{\text{N}}1$  mechanism then racemisation takes place while if it follows  $\text{S}_{\text{N}}2$  mechanism than inversion takes places.
- B. Chlorobromocarbons are used in fire extinguishers.
- C. In vicinal dihalides, halogen atoms are present on the adjacent carbon atom. Bromination of alkenes will give vicinal dihalides.
- D. Alkylidene halides are named as *gem*-dihalides. In *gem*-dihalides halogen atoms are present on same carbon atom.
- E. Elimination of HX from alkylhalide follows Saytzeff rule. This rule states that “in dehydrohalogenation reactions, the preferred product is that alkene which has the greater number of alkyl groups attached to the doubly bonded carbon atoms”.

**Q. 81** Match the structures of compounds given in Column I with the classes of compounds given in Column II.

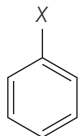
Column I	Column II
A. $\text{CH}_3 - \underset{\text{X}}{\text{CH}} - \text{CH}_3$	1. Aryl halide
B. $\text{CH}_2 = \text{CH} - \text{CH}_2 - \text{X}$	2. Alkyl halide
C. 	3. Vinyl halide
D. $\text{CH}_2 = \text{CH} - \text{X}$	4. Allyl halide

**Ans. A.** → (2)    **B.** → (4)    **C.** → (1)    **D.** → (3)

- A. In alkyl halide, halogen atom is bonded to  $sp^3$  hybridised carbon atom, which may be further bonded to one, two or three alkyl group, *i.e.*,  $CH_3-CH(X)-CH_3$
- B. Allyl halides are the compounds in which the halogen atom is bonded to  $sp^3$  hybridised carbon atom next to carbon-carbon double bond. *i.e.*,  $CH_2=CH-CH_2-X$
- C. Aryl halides are the compounds in which the halogen atom is bonded to  $sp^2$  hybridised carbon atom of an aromatic ring, *i.e.*,  $C_6H_5X$
- D. Vinyl halides are the compounds in which the halogen atom is bonded to an  $sp^2$  hybridised carbon atom of a carbon-carbon double bond, *i.e.*,  $CH_2=CH-X$

**Q. 82** Match the reactions given in Column I with the types of reactions given in Column II.

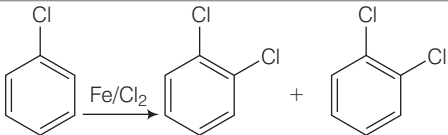
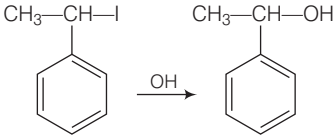
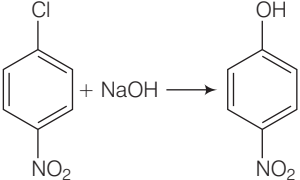
Column I	Column II
<p>A. </p>	1. Nucleophilic aromatic substitution
<p>B. <math>CH_3-CH=CH_2 + HBr \longrightarrow CH_3-\underset{\text{Br}}{\text{CH}}-CH_3</math></p>	2. Electrophilic aromatic substitution
<p>C. </p>	3. Saytzeff elimination
<p>D. </p>	4. Electrophilic addition
<p>E. <math>CH_3CH_2\underset{\text{Br}}{\text{CH}}CH_3 \xrightarrow[\text{KOH}]{\text{alkaline}} CH_3CH=CHCH_3</math></p>	5. Nucleophilic substitution ( $S_N1$ )

**Ans. A.** → (2)    **B.** → (4)    **C.** → (5)    **D.** → (1)    **E.** → (3)

- A. In this reaction, an electrophile  $Cl^+$  attacks on to the benzene ring and substitution takes place.
- B. In this reaction, addition of HBr takes place on to the doubly bonded carbons of propene in accordance with Markownikoff's rule and electrophilic addition takes place.
- C. In this reaction, the reactant is secondary halide. Here, halogen atom is substituted by hydroxy ion. As it is secondary halide so it follows  $S_N1$  mechanism.
- D. In this reaction, halogen atom is directly bonded to aromatic ring. So, It is nucleophilic aromatic substitution as  $^-OH$  group has substituted halogen of given compound.
- E. It is an elimination reaction. It follows Saytzeff elimination rule.

**Q. 83** Match the structures given in Column I with the names in Column II.

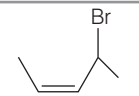
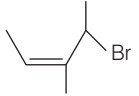
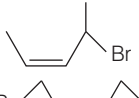
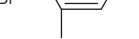
Column I	Column II
A. 	1. 4-bromopent-2-ene
B. 	2. 4-bromo-3-methylpent-2-ene
C. 	3. 1-bromo-2-methylbut-2-ene
D. 	4. 1-bromo-2-methylpent-2-ene

**Ans.** A. → (1)    B. → (2)    C. → (3)    D. (4)

- A. The IUPAC name of compound (A) is 4-bromopent-2-ene.  
 B. The IUPAC name of compound (B) is 4-bromo-3-methyl pent-2-ene.  
 C. The IUPAC name of compound (C) is 1-bromo-2-methyl but-2-ene.  
 D. The IUPAC name of compound (D) is 1-bromo-2-methylpent-2-ene.

**Q. 84** Match the reactions given in Column I with the names given in Column II.

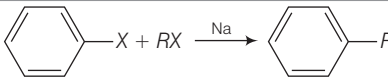
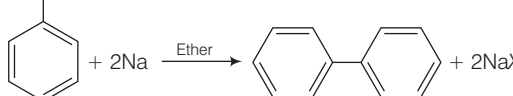
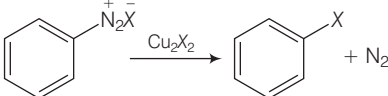
Column I	Column II
A. 	1. Fittig reaction
B. 	2. Wurtz-Fittig reaction
C. 	3. Finkelstein reaction
D. $C_2H_5Cl + NaI \xrightarrow{\text{Dry acetone}} C_2H_5I + NaCl$	4. Sandmeyer reaction

**Ans.** A. → (2)    B. → (1)    C. → (4)    D. → (3)

- A. A mixture of an alkyl halide and aryl halide gives an alkylarene when treated with sodium in dry ether and this is called Wurtz-Fittig reaction.  
 B. Aryl halides give analogous compounds when treated with sodium in dry ether, in which two aryl groups are joined together. It is called Fittig reaction.  
 C. Diazonium salt when treated with cuprous chloride or cuprous bromide gives chlorobenzene or bromobenzene.  
 The reaction is known as Sandmeyer's reaction.  
 D. Alkyl iodides are prepared by the reaction of alkyl chlorides with sodium iodide in dry acetone. The reaction is known as Finkelstein reaction.

## Assertion and Reason

In the following questions a statement of Assertion (A) followed by a statement of Reason (R) is given. Choose the correct answer out of the following choices.

- (a) Assertion and reason both are correct and reason is correct explanation of assertion.
- (b) Assertion and reason both are wrong statements.
- (c) Assertion is correct but reason is wrong statement.
- (d) Assertion is wrong but reason is correct statement.
- (e) Assertion and reason both are correct statements but reason is not correct explanation of assertion.

**Q. 85** Assertion (A) Phosphorus chlorides (tri and penta) are preferred over thionyl chloride for the preparation of alkyl chlorides from alcohols.  
Reason (R) Phosphorus chlorides give pure alkyl halides.

**Ans. (b)** Assertion and reason both are wrong statements.

**Correct Assertion** Thionyl chloride is preferred over  $\text{PCl}_3$  and  $\text{PCl}_5$  for the preparation of alkyl chlorides from alcohols.

**Correct Reason** Thionyl chloride gives pure alkyl halide as other two products ( $\text{SO}_2 + \text{HCl}$ ) are escapable gases.

**Q. 86** Assertion (A) The boiling points of alkyl halides decrease in the order  $\text{RI} > \text{RBr} > \text{RCl} > \text{RF}$   
Reason (R) The boiling points of alkyl chlorides, bromides and iodides are considerably higher than that of the hydrocarbon of comparable molecular mass.

**Ans. (e)** Assertion and reason both are correct statements but reason is not the correct explanation of assertion. For the same hydrocarbon part boiling point depends upon the atomic mass of halogen atom. Higher the mass of the halogen atom, higher will be the boiling point.

So, we can say that boiling point decreases with decrease in atomic mass of halogen atom.

**Q. 87** Assertion (A) KCN reacts with methyl chloride to give methyl isocyanide.  
Reason (R)  $\text{CN}^-$  is an ambident nucleophile.

**Ans. (d)** Assertion is wrong but reason is correct statement.

**Correct Assertion** KCN reacts with methyl chloride to give the mixture of methyl cyanide and methyl isocyanide in which methyl cyanide predominates because of stable C—C bond in methyl cyanide.

**Q. 88** Assertion (A) *tert*-butyl bromide undergoes Wurtz reaction to give 2,2,3,3-tetramethylbutane.

Reason (R) In Wurtz reaction, alkyl halides react with sodium in dry ether to give hydrocarbon containing double the number of carbon atoms present in the halide.

**Ans. (d)** Assertion is wrong but reason is correct statement.

**Correct Assertion-** *sec*-butyl bromide ( $2^\circ$  alkyl halide) undergoes Wurtz reaction to give 2,5-dimethylhexane.

**Q. 89** Assertion (A) Presence of a nitro group at *ortho* or *para* position increases the reactivity of haloarenes towards nucleophilic substitution. Reason (R) Nitro group, being an electron withdrawing group decreases the electron density over the benzene ring.

**Ans. (a)** Assertion and reason both are correct and reason is correct explanation of assertion.

Presence of nitro group at *ortho* or *para* position increases the reactivity of haloarenes towards nucleophilic substitution because  $-\text{NO}_2$  group, being an electron withdrawing group decreases the electron density over the benzene ring.

**Q. 90** Assertion (A) In monohaloarenes, further electrophilic substitution occurs at *ortho* and *para* positions.

Reason (R) Halogen atom is a ring deactivator.

**Ans. (e)** Assertion and reason both are correct statements but reason is not the correct explanation of assertion.

**Correct explanation** in monohaloarenes, halogen atom increases the electron density at *ortho* and *para* position. So, further electrophilic substitution occurs at *ortho* and *para* positions.

**Q. 91** Assertion (A) Aryl iodides can be prepared by reaction of arenes with iodine in the presence of an oxidising agent.

Reason (R) Oxidising agent oxidises  $\text{I}_2$  into HI.

**Ans. (c)** Assertion is correct but reason is wrong statement.

**Correct Reason** Oxidising agent oxidises HI into  $\text{I}_2$  to prevent the possibility of backward reaction.

**Q. 92** Assertion (A) It is difficult to replace chlorine by  $-\text{OH}$  in chlorobenzene in comparison to that in chloroethane.

Reason (R) chlorine carbon ( $\text{C}-\text{Cl}$ ) bond in chlorobenzene has a partial double bond character due to resonance

**Ans. (a)** Assertion and reason both are correct and reason is the correct explanation of assertion. It is difficult to replace chlorine by  $-\text{OH}$  in chlorobenzene in comparison to that in chloroethane because  $\text{C}-\text{Cl}$  bond in chlorobenzene has a partial bond character due to resonance.

**Q. 93** Assertion (A) Hydrolysis of (–)-2-bromooctane proceeds with inversion of configuration.

Reason (R) This reaction proceeds through the formation of a carbocation.

**Ans. (c)** Assertion is correct but reason is wrong statement.

**Correct Reason** This reaction proceeds through  $S_N2$  mechanism, in which  $^-OH$  ion attacks at  $180^\circ$  to the halogen atom of 2-bromooctane which leads to the inversion of configuration.

**Q. 94** Assertion (A) Nitration of chlorobenzene leads to the formation of *m*-nitrochlorobenzene.

Reason (R)  $-NO_2$  group is a *m*-directing group.

**Ans. (d)** Assertion is wrong but reason is correct statement.

**Correct Assertion** Chlorination of nitrobenzene leads to the formation of *m*-nitrochlorobenzene because  $-NO_2$  group deactivates the ring because it is *meta* directing.

## Long Answer Type Questions

**Q. 95** Some alkyl halides undergo substitution whereas some undergo elimination reaction on treatment with bases. Discuss the structural features of alkyl halides with the help of examples which are responsible for this difference.

**Ans.** Primary alkyl halides follow  $S_N2$  mechanism in which a nucleophile attacks at  $180^\circ$  to the halogen atom. A transition state is formed in which carbon is bonded to two nucleophiles and finally halogen atom is pushed out. In  $S_N2$  mechanism, substitution of nucleophile takes place as follows

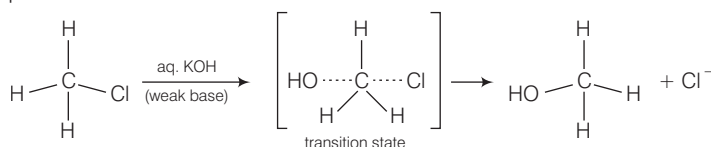

Thus, in  $S_N2$  mechanism, substitution takes place. Tertiary alkyl halides follow  $S_N1$  mechanism. In this case, *tert* alkyl halides form  $3^\circ$  carbocations. Now, if the reagent used is a weak base then substitution occurs while if it is a strong base then instead of substitution elimination occurs.

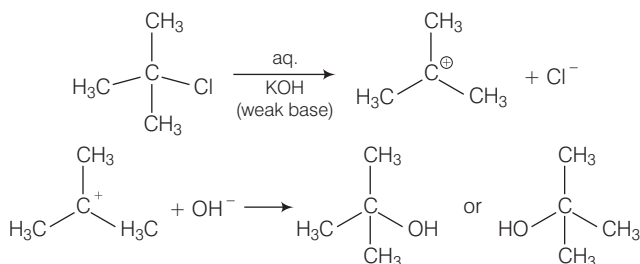

Here, the reagent used is aq. KOH. It is a weak base so, substitution takes place.

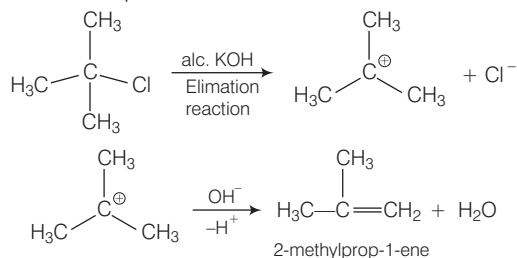

As alc. KOH is a strong base, so elimination competes over substitution and alkene is formed.

**Q. 96** Some halogen containing compounds are useful in daily life. Some compounds of this class are responsible for exposure of flora and fauna to more and more of UV light which causes destruction to a great extent. Name the class of these halocompounds. In your opinion, what should be done to minimise harmful effects of these compounds.

**Ans.** Some halogen containing compounds are useful in daily life are as follows

**Dichloromethane** It is used as a solvent as a paint remover, as a propellant in aerosols, and as a process solvent in the manufacture of drugs. It is also used as a metal cleaning and finishing solvent.

**Trichloromethane** It is employed as a solvent for fats, alkaloids, iodine and other substances.

**Triodomethane** It is used as an antiseptic. Now, it has been replaced by some other compounds because of its objectionable smell.

But some compounds of this class are responsible for exposure of flora and fauna to more and more of UV light which causes destruction to great extent.

*These are as follows*

- (i) **Tetrachloromethane** When carbon tetrachloride is released into the air, it rises to the atmosphere and depletes the ozone layer. Depletion of the ozone layer is believed to increase human exposure to UV rays leading to increased skin cancer, eye diseases and disorders, and possible disruption of the immune system. These UV rays cause damage to plants, and reduction of plankton populations in the ocean's photic zone.
- (ii) **Freons** Freon-113 is likely to remain in the air long enough to reach the upper atmosphere. Here, it provides chlorine atoms which damage the ozone layer. Because of this depletion UV rays enters in our atmosphere and become responsible for damage to great extent.
- (iii) ***p*-*p'*-Dichlorodiphenyl trichloroethane (DDT)**

DDT is not completely biodegradable. Instead, it gets deposited in fatty tissues. If ingestion continues for a long time, DDT builds up within the animal and effect the reproductive system.

To minimise the harmful impacts of these compounds *i.e.*, freons, hydrofluorocarbons, fluorocarbons and hydrocarbons can be straight used to make refrigerants and air-conditioning equipments. They are stable in the stratosphere and secure for flora and fauna.

**Q. 97** Why are aryl halides less reactive towards nucleophilic substitution reactions than alkyl halides? How can we enhance the reactivity of aryl halides?

**Ans.** Aryl halides are less reactive towards nucleophilic substitution reaction due to the following reasons

(i) In haloarenes, the lone pair of electron on halogen are in resonance with benzene ring. So, C — Cl bond acquires partial double bond character which strengthen C — Cl bond. Therefore, they are less reactive towards nucleophilic substitution reaction.

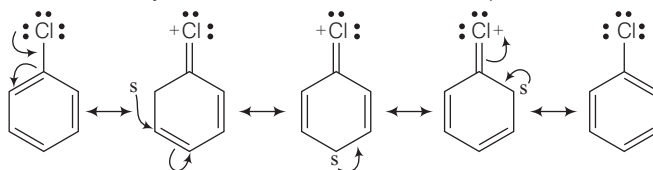

(ii) In haloarenes, the carbon atom attached to halogen is  $sp^2$  hybridised. The  $sp^2$  hybridised carbon is more electronegative than  $sp^3$  hybridised carbon. This  $sp^2$ -hybridised carbon in haloarenes can hold the electron pair of C — X bond more tightly and make this C — Cl bond shorter than C — Cl bond of haloalkanes.

Since, it is difficult to break a shorter bond than a longer bond, therefore, haloarenes are less reactive than haloalkanes.

In haloarenes, the phenyl cation will not be stabilised by resonance therefore  $S_N1$  mechanism ruled out.

(iv) Because of the repulsion between the nucleophile and electron rich arenes, aryl halides are less reactive than alkyl halides.

The reactivity of aryl halides can be increased by the presence of an electron withdrawing group ( $-\text{NO}_2$ ) at *ortho* and *para* positions. However, no effect on reactivity of haloarenes is observed by the presence of electron withdrawing group at *meta*-position. Mechanism of the reaction is as depicted with  $^-\text{OH}$  ion.

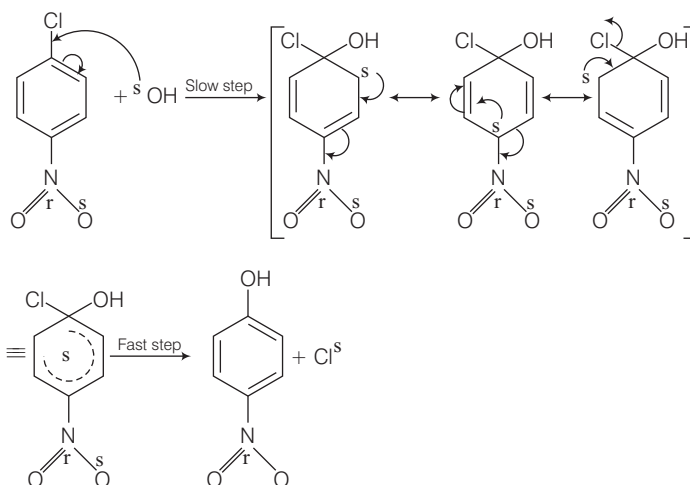



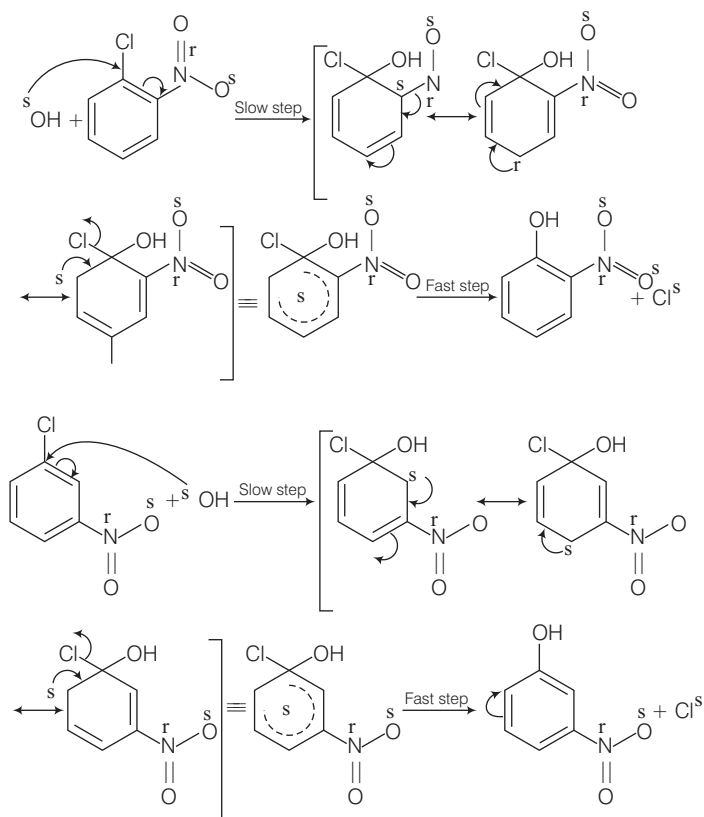

From the above resonance, it is very clear that electron density is rich at *ortho* and *para* positions. So, presence of EWG will facilitate nucleophilic at *ortho* and *para* positions not on *meta* position.



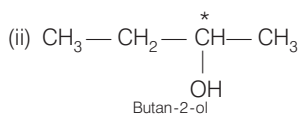

In this compound, asterisk marked carbon is chiral carbon as all four substituents, attached to it are different.

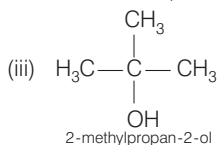

Here, again carbon is not chiral in nature.

So, only one alcohol is chiral in nature and the correct option is (a).

**Q. 3** What is the correct order of reactivity of alcohols in the following reaction?

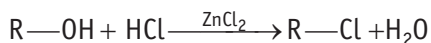

(a)  $1^\circ > 2^\circ > 3^\circ$

(b)  $1^\circ < 2^\circ > 3^\circ$

(c)  $3^\circ > 2^\circ > 1^\circ$

(d)  $3^\circ > 1^\circ > 2^\circ$

**Ans. (c)** The given reaction is nucleophilic substitution reaction in which —OH group is replaced by —Cl. Tertiary alcohols, when react with HCl in presence of  $\text{ZnCl}_2$ , form tertiary carbocation.

This intermediate  $3^\circ$  carbocation is more stable than  $2^\circ$  carbocation as well as  $1^\circ$  carbocation. Higher the stability of intermediate, higher will be the reactivity of reactant molecule.

So, the order of reactivity of alcohols in the given reaction is  $3^\circ > 2^\circ > 1^\circ$  and correct option is (c).

**Q. 4**  $\text{CH}_3\text{CH}_2\text{OH}$  can be converted into  $\text{CH}_3\text{CHO}$  by .....

(a) catalytic hydrogenation

(b) treatment with  $\text{LiAlH}_4$

(c) treatment with pyridinium chlorochromate

(d) treatment with  $\text{KMnO}_4$

**Ans. (c)** Ethanal ( $\text{CH}_3\text{CHO}$ ) is an oxidised product of ethanol. Pyridinium chlorochromate ( $\text{C}_5\text{H}_5\text{NHClCrO}_3$ ) oxidises primary alcohols to aldehydes. Strong oxidising agents such as  $\text{KMnO}_4$  are used for getting carboxylic acid from alcohols.

The oxidation process can be stopped at the aldehyde stage if Cr(VI) reagents such as Collin's reagent ( $\text{CrO}_3 \cdot 2\text{C}_5\text{H}_5\text{N}$ ), Corey's reagent or pyridinium chlorochromate and pyridinium dichromate [ $(\text{C}_5\text{H}_5\text{NH}_2)^{2+}\text{Cr}_2\text{O}_7^{2-}$ ] in anhydrous medium are used as the oxidising agent. So, the correct option is (c).

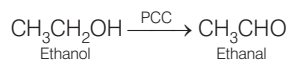

**Q. 5** The process of converting alkyl halides into alcohols involves .....

- (a) addition reaction (b) substitution reaction  
(c) dehydrohalogenation reaction (d) rearrangement reaction

**Ans. (b)** An addition reaction is a reaction where two or more molecules combine to form a larger one. These reactions occur to change the unsaturated compound to saturated compound. In dehydrohalogenation reaction, alkyl halides give alkenes.

Rearrangement gives the structural isomers of the reactant while in substitution reaction one of the group or an atom is replaced by other group. Therefore, the process of converting alkyl halides into alcohols involves substitution reaction.

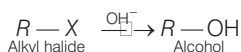

#### Reaction of alkyl halides

Primary alkyl halides –  $S_N^2$

Secondary alkyl halides –  $S_N^1$

Tertiary alkyl halides –  $S_N^1$

**Q. 6** Which of the following compounds is aromatic alcohol?

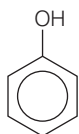

(A)

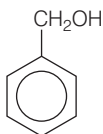

(B)

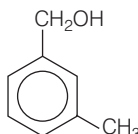

(C)

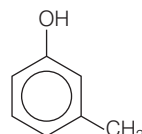

(D)

- (a) A, B, C, D (b) A, D (c) B, C (d) A

**Ans. (c)** Phenol is also known as 'carbolic acid' cannot be considered as aromatic alcohol. It is quite separate branch of compound called phenols. So, compound (A) *i.e.*, phenol and compound (D) *i.e.*, a derivative of phenol cannot be considered as aromatic alcohol.

On the other hand, compound (B) and (C), — OH group is bonded to  $sp^3$  hybridised carbon which in turn is bonded to benzene ring. Hence, the correct option is (c).

**Q. 7** Give IUPAC name of the compound given below.

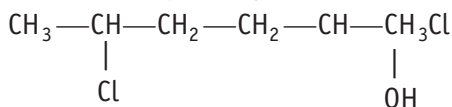

- (a) 2-chloro-5-hydroxyhexane (b) 2-hydroxy-5-chlorohexane  
(c) 5-chlorohexan-2-ol (d) 2-chlorohexan-5-ol

**Ans. (c)**

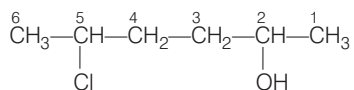

The correct IUPAC name of the compound is 5-chlorohexan-2-ol.

Hence, option (c) is the correct answer.

**Q. 8** IUPAC name of *m*-cresol is .....

- (a) 3-methylphenol (b) 3-chlorophenol  
(c) 3-methoxyphenol (d) benzene-1, 3-diol

**Ans. (a)** The structure of *m*-cresol is

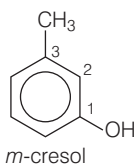

IUPAC name is 3-methylphenol because —OH is the functional group and the methyl is substituent.

**Q. 9** IUPAC name of the compound  $\text{CH}_3 - \underset{\text{CH}_3}{\text{CH}} - \text{OCH}_3$  is .....

- (a) 1-methoxy-1-methylethane (b) 2-methoxy-2-methylethane  
(c) 2-methoxypropane (d) isopropylmethyl ether

**Ans. (c)**

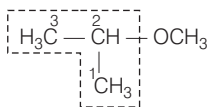

IUPAC name of the above compound is 2-methoxypropane and correct option is (c).

**Q. 10** Which of the following species can act as the strongest base?

- (a)  $^{\ominus}\text{OH}$  (b)  $^{\ominus}\text{OR}$   
(c)  $^{\ominus}\text{OC}_6\text{H}_5$  (d)  $^{\ominus}\text{O}$ -

**Thinking Process**

To compare the species, the point to be noted that weak acid has strong conjugate base and vice-versa. Write the corresponding acid of the given base and choose the weakest acid among these.

**Ans. (b)** Weakest acid has the strongest conjugate base. *ROH* is the acid of  $\text{RO}^-$  conjugate

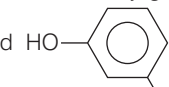
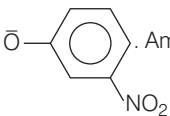
base,  $\text{HOH}$  is the acid of  $^{\ominus}\text{OH}$ ,  $\text{C}_6\text{H}_5\text{OH}$  is the acid of  $\text{C}_6\text{H}_5\text{O}^-$  and  $\text{HO}$ - is the acid of  $\text{O}^-$ -. Among all these acids, *ROH* is the weakest acid.

Therefore, the strongest base is  $\text{RO}^-$  and the correct option is (b).

**Q. 11** Which of the following compounds will react with sodium hydroxide solution in water?

- (a)  $\text{C}_6\text{H}_5\text{OH}$  (b)  $\text{C}_6\text{H}_5\text{CH}_2\text{OH}$   
(c)  $(\text{CH}_3)_3\text{COH}$  (d)  $\text{C}_2\text{H}_5\text{OH}$

**Ans. (a)** Phenol is more acidic in nature because by the loss of one proton, it gives phenoxide ion. This phenoxide ion is resonance stabilised. As phenoxide ion is a stable intermediate so, the tendency to give proton is more in phenol than the others. Phenols being more acidic than alcohols, dissolves in NaOH.

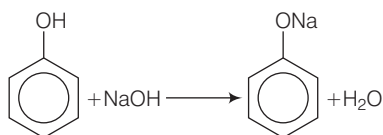

Therefore, option (a) is the correct.

**Q. 12** Phenol is less acidic than .....

- (a) ethanol (b) *o*-nitrophenol  
(c) *o*-methylphenol (d) *o*-methoxyphenol

**Thinking Process**

This question is based on the acidic character of phenol. Electron withdrawing group at *o*- and *p*-position w.r. t. —OH group of phenol, increases the acidic strength.

**Ans. (b)** In *o*-nitrophenol, nitro group is present at *ortho* position. Presence of electron withdrawing group at *ortho* position increases the acidic strength. On the other hand, in *o*-methylphenol and in *o*-methoxyphenol, electron releasing group (—CH<sub>3</sub>, —OCH<sub>3</sub>) are present.

Presence of these groups at *ortho* or *para* positions of phenol decreases the acidic strength of phenols. So, phenol is less acidic than *o*-nitrophenol.

**Q. 13** Which of the following is most acidic?

- (a) Benzyl alcohol (b) Cyclohexanol  
(c) Phenol (d) *m*-chlorophenol

**Ans. (d)** Alpha carbon of benzyl alcohol and cyclohexanol is  $sp^3$  hybridised while in phenol and *m*-chlorophenol, it is  $sp^2$  hybridised. In *m*-chlorophenol electron withdrawing group (—Cl) is present at *meta* position.

Presence of electron withdrawing group increases the acidic strength. So, *m*-chlorophenol is most acidic among all the given compounds. The correct option is (d).

**Q. 14** Mark the correct order of decreasing acid strength of the following compounds.

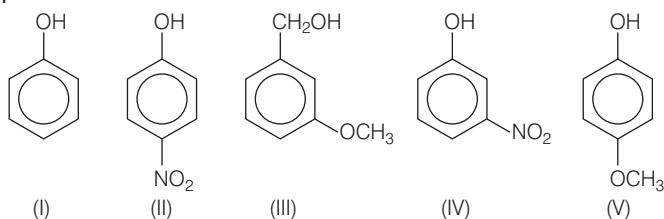

- (a) V > IV > II > I > III (b) II > IV > I > III > V  
(c) IV > V > III > II > I (d) V > IV > III > II > I

**Ans. (b)** Presence of electron withdrawing group on phenols, increases its acidic strength. So, both compounds *i.e.*, *p*-nitrophenol (II) and *m*-nitrophenol (IV) are stronger acid than (I). If this —NO<sub>2</sub> group is present at *p*-position, then it exerts both —*I* and —*R* effect but if it is present at *meta* position, then it exerts only —*I* effect. Therefore, *p*-nitrophenol is much stronger acid than *m*-nitrophenol.

On the other hand, presence of electron releasing group on phenol, decreases its acidic strength. If —OCH<sub>3</sub> group is present at *meta* position, it will not exert +*R* effect but exert —*I* effect.

But, if it is present at *para* position, then it will exert +*R* effect. Therefore, *m*-methoxy phenol is more acidic than *p*-methoxy phenol.

Hence, the correct option is (b).

**Q. 15** Mark the correct increasing order of reactivity of the following compounds with HBr/HCl.

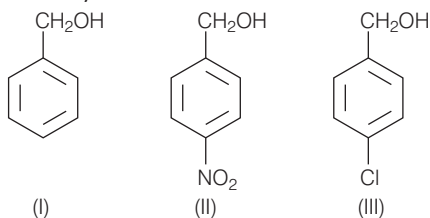

- (a) I < II < III      (b) II < I < III      (c) II < III < I      (d) III < II < I

💡 **Thinking Process**

*This question is based on conceptual mixing of substitution reaction carbocation and reactivity. Nucleophilic substitution reactions depend upon the stability of carbocation. Higher the stability of carbocation (intermediate), higher will be the reactivity of reactant molecule.*

**Ans. (c)** Reaction of the given compounds with HBr/HCl is a nucleophilic substitution reaction. It follows S<sub>N</sub><sup>1</sup> mechanism. S<sub>N</sub><sup>1</sup> mechanism depends upon the stability of carbocation. Presence of electron withdrawing group decreases the stability of carbocation. In compound (II) and (III) EWG is present at *para* position.

Since, —NO<sub>2</sub> group is a stronger EWG than —Cl. So, NO<sub>2</sub>—C<sub>6</sub>H<sub>5</sub>— $\overset{+}{\text{C}}\text{H}_2$  carbocation will be less stable than Cl—C<sub>6</sub>H<sub>5</sub>— $\overset{+}{\text{C}}\text{H}_2$  carbocation.

Thus, the order of stability of carbocation is

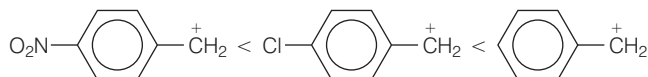

Therefore, compound (II) is least reactive and correct option is (III).

**Q. 16** Arrange the following compounds in increasing order of boiling point. Propan-1-ol, butan-1-ol, butan-2-ol, pentan-1-ol

- (a) Propan-1-ol, butan-2-ol, butan-1-ol, pentan-1-ol  
 (b) Propan-1-ol, butan-1-ol, butan-2-ol, pentan-1-ol  
 (c) Propan-1-ol, butan-2-ol, butan-1-ol, pentan-1-ol  
 (d) Propan-1-ol, butan-1-ol, butan-2-ol, pentan-1-ol

### 💡 Thinking Process

This question is based on the boiling point of the compound. Boiling point increases with increase in the number of carbon atoms and decreases with increase of branching in carbon chain.

**Ans. (a)** Boiling point increases with increase in the number of carbon atoms because of increase in molecular mass. So, the boiling point of pentan-1-ol is more than that of all other given compounds. Further, among isomeric alcohols, 1° alcohols have higher boiling points than 2° alcohols because of higher surface area in 1° alcohols. Therefore, boiling point increase in the order



Here, the correct option is (a).

## Multiple Choice Questions (More Than One Options)

**Q. 17** Which of the following are used to convert  $RCHO$  into  $RCH_2OH$ ?

- (a)  $H_2/Pd$
- (b)  $LiAlH_4$
- (c)  $NaBH_4$
- (d) Reaction with  $RMgX$  followed by hydrolysis

**Ans. (a, b, c)**

Conversion of aldehyde into alcohol is a reduction reaction. This reduction can be carried out by adding hydrogen in presence of finely divided metal catalyst such as platinum, palladium or nickel.

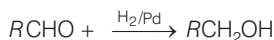

It can also be prepared by using  $NaBH_4$  and  $LiAlH_4$  as a reducing agent.

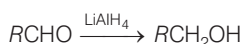
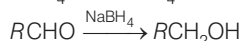

Reaction of  $RMgX$  with any aldehyde other than methanal gives secondary alcohols not the primary alcohols.

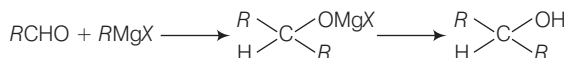

(Where,  $R = -C_2H_5, C_3H_7$  etc.)

**Q. 18** Which of the following reactions will yield phenol?

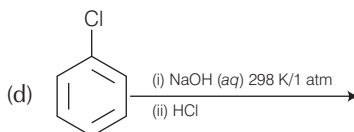
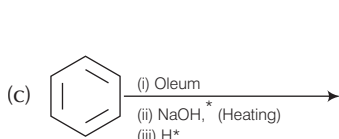
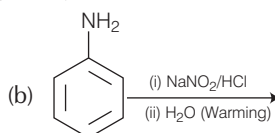
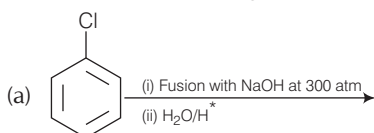

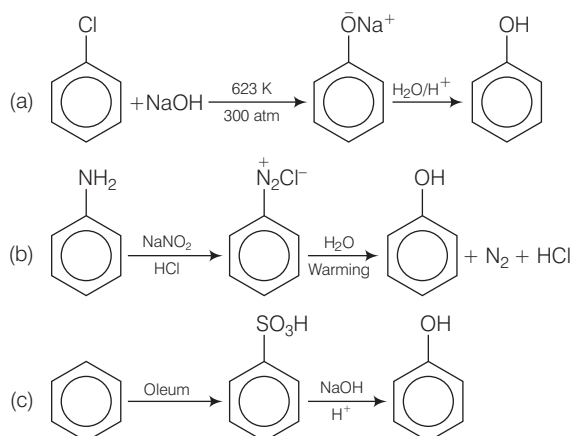

**Ans. (a, b, c)**

Haloarenes are less reactive towards nucleophilic substitution reaction. Therefore, it requires very high temperature and pressure. Chlorobenzene does not undergo hydrolysis on treatment with *aq.* NaOH at 298 K and 1 atm.

Therefore, correct options are (a), (b) and (c).

**Q. 19** Which of the following reagents can be used to oxidise primary alcohols to aldehydes?

- (a)  $\text{CrO}_3$  in anhydrous medium      (b)  $\text{KMnO}_4$  in acidic medium  
 (c) Pyridinium chlorochromate      (d) Heat in the presence of Cu at 573K

**Ans. (a, c, d)**

$\text{CrO}_3$  in anhydrous medium is used to oxidise primary alcohols to aldehydes.

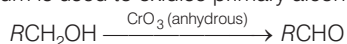

Acidic  $\text{KMnO}_4$  is a very strong oxidising agent. It oxidises primary alcohols into carboxylic acid.

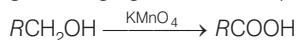

Pyridinium chlorochromate ( $\text{C}_5\text{H}_5^+\text{NHClCrO}_3^-$ ) is a very good reagent for the oxidation of primary alcohols to aldehydes.



When the vapours of primary alcohols are passed over heated copper at 573 K, dehydrogenation takes place and an aldehyde is formed.

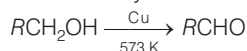

**Q. 20** Phenol can be distinguished from ethanol by the reactions with ..... .

- (a)  $\text{Br}_2$ /water      (b) Na      (c) neutral  $\text{FeCl}_3$       (d) All of these

**Ans. (a, c)**

Ethanol does not react with  $\text{Br}_2$ /water while phenol gives 2, 4, 6-tribromophenol as white precipitate.

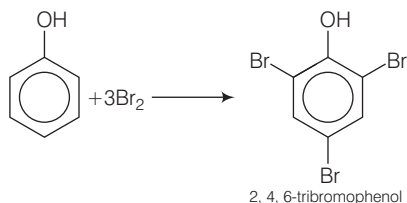

Ethanol and phenol both react with sodium, so phenol cannot be distinguished from ethanol by the reaction with sodium.

Ethanol does not give any reaction with neutral  $\text{FeCl}_3$  solution while phenol gives purple, blue or red colour when treated with neutral  $\text{FeCl}_3$ .

Therefore, correct options are (a) and (c).

**Q. 21** Which of the following are benzylic alcohols?

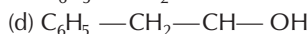
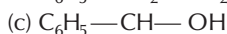
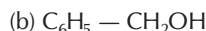

**Ans. (b, c)**

In benzylic alcohols, the  $-\text{OH}$  group is attached to a  $sp^3$  hybridised carbon atom next to an aromatic ring. In compound (a) and (d), the  $-\text{OH}$  group is attached to a  $sp^3$  hybridised carbon atom but this carbon is not attached to the benzene ring.

On the other hand, in compound (a) and (c), the  $-\text{OH}$  group is attached to a  $sp^3$  hybridised carbon atom next to an aromatic ring.

## Short Answer Type Questions

**Q. 22** What is the structure and IUPAC name of glycerol?

**Ans.** Glycerol is the trihydric alcohol. Structure of glycerol is

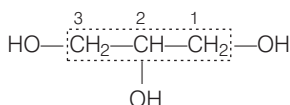

So, IUPAC name is — propan- 1, 2, 3-triol.

**Q. 23** Write the IUPAC name of the following compounds.

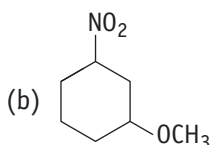
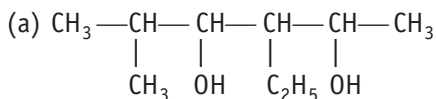

**Ans.** The correct IUPAC name of the following compounds are given below

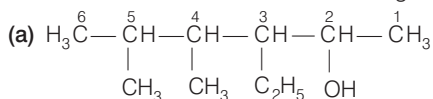

IUPAC name  $\rightarrow$  3-ethyl-5-methylhexan-2, 4-diol.

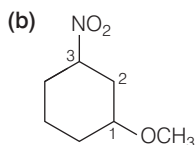

IUPAC name  $\rightarrow$  1-methoxy-3-nitrocyclohexane.

**Q. 24** Write the IUPAC name of the compound given below.

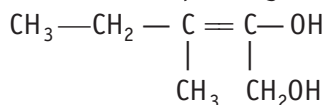

**Ans.** The IUPAC name of the compound given below is

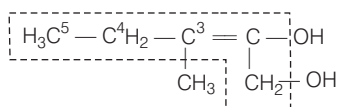

3-methylpent-2-ene-1, 2-diol.

**Q. 25** Name the factors responsible for the solubility of alcohols in water.

**Ans.** Solubility of alcohols in water depends upon the two factors.

- (i) **Hydrogen bonding** Higher the extent of hydrogen bonding, higher is the solubility. The hydrogen group of alcohol form hydrogen bonding. Solubility increases with increase in the number of  $-\text{OH}$  groups in alcohols of comparable molecular masses.

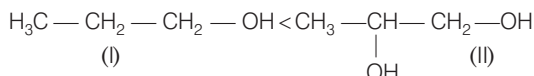

- (I) Compound (II) will form stronger H-bond due to two  $-\text{OH}$  group and hence has higher boiling point.
- (ii) **Size of alkyl/aryl group** Higher the size of alkyl/aryl group (hydrocarbon part), lower is the extent of hydrogen bonding and lower is the solubility. Hence,

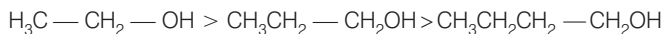

**Q. 26** What is denatured alcohol?

**Ans.** Alcohol is used in large quantities in the manufacture of alcoholic liquors. Its continuous use damages the various vital organs. Therefore, to refrain the people from drinking alcohol, heavy excise duty is levied on the sale of alcoholic beverages. But, it is used in various industries as it is a very good solvent.

Therefore, industrial alcohol must be cheap. Thus, to provide cheaper alcohol to industries and to refrain people from drinking alcohol, it is mixed with some copper sulphate, pyridine, methyl alcohol or acetone.

Alcohol is made unfit for drinking by mixing some quantity of any of these substances in it. This is called denatured alcohol.

**Q. 27** Suggest a reagent for the following conversion.

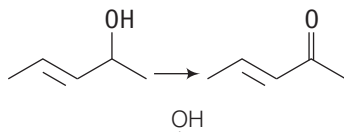

**Ans.** The given reactant is  $\text{H}_3\text{C}-\text{CH}=\text{CH}-\text{CH}(\text{OH})-\text{CH}_3$ . It is a secondary alcohol. Secondary alcohol ( $>\text{CHOH}$ ) gives ketone when oxidises by  $\text{CrO}_3$  or pyridinium chlorochromate without carrying out oxidation at the double bond.

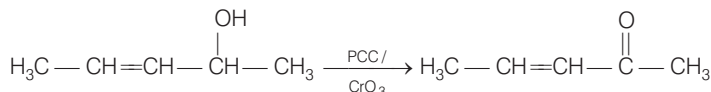

**Q. 28** Out of 2-chloroethanol and ethanol which is more acidic and why?

**Ans.** 2-chloroethanol is more acidic than ethanol. Due to  $-I$  effect (electron withdrawing group) of the Cl-atom electron density in  $\text{O}-\text{H}$  bond decreases. So,  $\text{O}-\text{H}$  bond of 2-chloroethanol becomes weaker than  $\text{O}-\text{H}$  bond of ethanol. Thus, 2-chloroethanol is more acidic than ethanol.

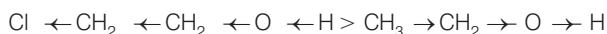

Stronger acid due to  $-I$  effect of Cl.

**Q. 29** Suggest a reagent for conversion of ethanol to ethanal.

**Ans.** Ethanol can be oxidised into ethanal by using pyridinium chlorochromate.

( $\text{C}_6\text{H}_5\text{NHClCrCrO}_3$ ) in  $\text{CH}_2\text{Cl}_2$ .

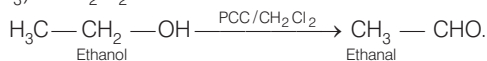

**Q. 30** Suggest a reagent for conversion of ethanol to ethanoic acid.

**Ans.** Ethanol can be converted into ethanoic acid by using acidified  $\text{KMnO}_4$  or  $\text{K}_2\text{Cr}_2\text{O}_7$ .

Both  $\text{KMnO}_4$  and  $\text{K}_2\text{Cr}_2\text{O}_7$  are strong oxidising agents.

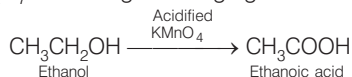

**Q. 31** Out of *o*-nitrophenol and *p*-nitrophenol, which is more volatile? Explain.

**Ans.** *o*-nitrophenol is more volatile than *p*-nitrophenol due to presence of intramolecular hydrogen bonding. In *para* nitrophenol intermolecular hydrogen bonding is present. This intermolecular hydrogen bonding causes the association of molecules.

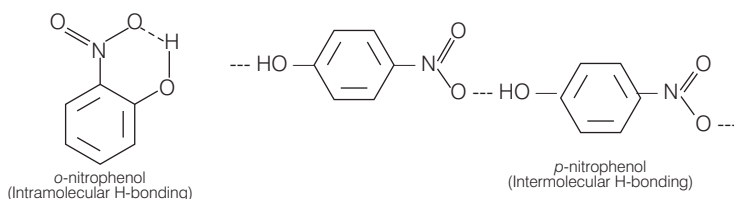

**Q. 32** Out of *o*-nitrophenol and *o*-cresol which is more acidic?

**Ans.** The acidic character of alcohols is due to the polar nature of O—H bond. Higher the polarity of O—H bond, more will be the acidic strength. Due to  $-I$  and  $-R$  effect of nitro group, electron density decreases in the O—H bond of *o*-nitrophenol and thus polarity increases.

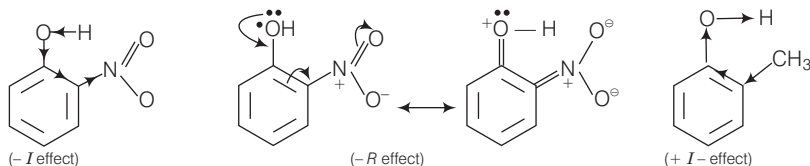

Whereas due to  $+I$  effect of  $-\text{CH}_3$  group, electron density increases in the O—H bond of *o*-cresol. Thus, O—H bond of *o*-nitrophenol is weaker than O—H bond of *o*-cresol and *o*-nitrophenol is more acidic than *o*-cresol.

**Q. 33** When phenol is treated with bromine water, white precipitate is obtained. Give the structure and the name of the compound formed.

**Ans.** When phenol is treated with bromine water, white ppt. of 2, 4, 6 – tribromophenol is obtained.

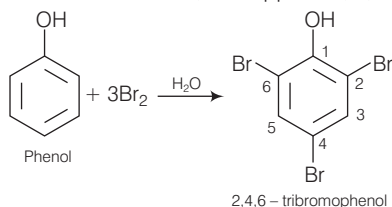

**Q. 34** Arrange the following compounds in increasing order of acidity and give a suitable explanation.

Phenol, *o*-nitrophenol, *o*-cresol

**Ans.** Nitro group shows  $-I$  and  $-R$  effect as follows

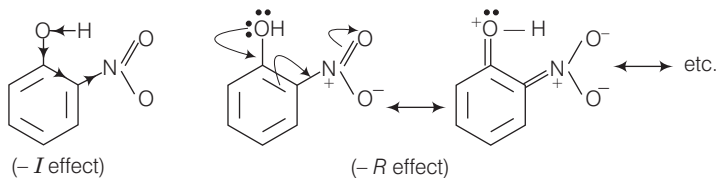

Due to this  $-I$  and  $-R$  effect of *o*-nitrophenol, it is a stronger acid than phenol. On the other hand,  $-\text{CH}_3$  group produces  $+I$  effect  $-I$  and  $-R$  effect increases the acidic strength by increasing the polarity of  $-\text{OH}$  bond while  $+I$  effect decreases the polarity due to increase in electron density on  $-\text{OH}$  bond. So, *o*-cresol is a weaker acid than phenol. Thus, the correct order is *o*-cresol < phenol < *o*-nitrophenol.

**Q. 35** Alcohols react with active metals e.g., Na, K etc., to give corresponding alkoxides. Write down the decreasing order of reactivity of sodium metal towards primary, secondary and tertiary alcohols.

**Thinking Process**

*This question is based on the concept of the acidity and reactivity. The acidic character of alcohols is due to the polar nature of the O—H bond.*

**Ans.** An electron releasing group produces + I effect so it increases the electron density on oxygen and decreases the polarity of O—H bond. As the number of alkyl group increases from 1° to 3° alcohols, the electron density on the O—H bond increases.

It will finally decrease the polarity and increase the strength of O—H bond in going from 1° to 3° alcohols. Thus, acidic strength decreases in the following order

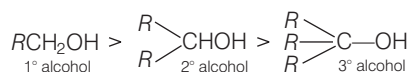

As we know that, sodium metal is basic in nature and alcohols are acidic in nature. Thus, reactivity of alcohol with sodium metal decreases with decrease in acidic strength. Therefore, the correct order is 1° > 2° > 3°.

**Q. 36** What happens when benzene diazonium chloride is heated with water?

**Ans.** When benzene diazonium chloride is heated with water then phenol is formed.

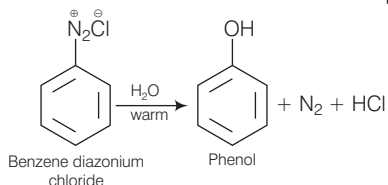

**Q. 37** Arrange the following compounds in decreasing order of acidity.



**Ans.** A stronger acid displaces a weaker acid from its salt. When RONA is treated with H<sub>2</sub>O, it forms ROH. So, water is a stronger acid than ROH.

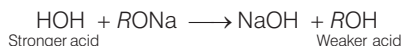

Similarly, when sodium ethynide is treated with water and alcohol, then acetylene is obtained.

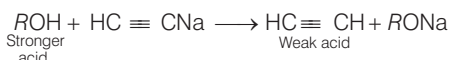
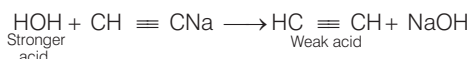

Thus, water and alcohol are stronger acid than ethyne and the decreasing order of acidity of given compounds are

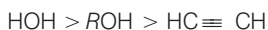



**Q. 41** Explain why is OH group in phenols more strongly held as compared to OH group in alcohols?

**Ans.** In phenols, the electron pairs on oxygen atom of —OH group are in conjugation (or resonance) with  $\pi$  electrons of the ring and the following resonating structures are possible

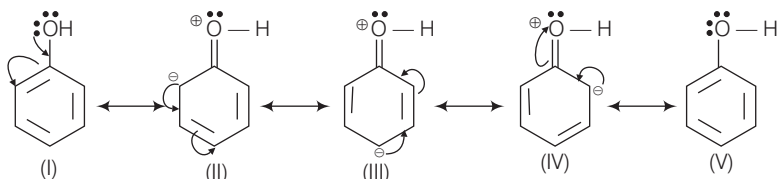

Out of these five resonating structures, II, III and IV structures contain a carbon-oxygen double bond character. In other words, carbon-oxygen bond in phenol acquires a partial double bond character due to resonance.

But in alcohols carbon-oxygen bond in alcohols is purely single bond. Therefore, —OH group in phenols is more strongly held as compared to —OH group in alcohols.

**Q. 42** Explain why nucleophilic substitution reactions are not very common in phenols?

**Ans.** Resonance is an important factor in phenols. During resonance —OH group in phenol gives its electrons to the benzene ring. As a result of this, the electron density on benzene ring is very high. This increased electron density repels nucleophiles.

Therefore, nucleophiles cannot attack the benzene ring and phenols usually do not give nucleophilic substitution reaction.

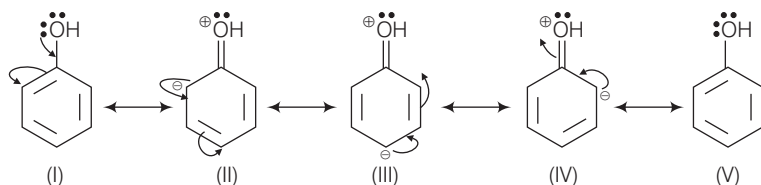

Resonance in phenols

**Q. 43** Preparation of alcohols from alkenes involves the electrophilic attack on alkene carbon atom. Explain its mechanism.

**Ans.** Preparation of alcohols from alkene by the hydration of alkenes in presence of sulphuric acid.

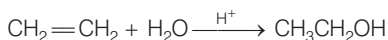

This addition reaction takes place in accordance with Markownikoff's rule.

**Mechanism** The mechanism of the reaction involves the following three steps

**Step 1** Protonation of alkene to form carbocation by electrophilic attack of  $\text{H}_3\text{O}^+$ .

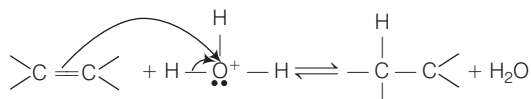

**Step 2** Attack of water molecule to the secondary carbocation.

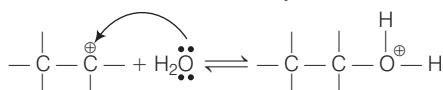







**Q. 50** Ethers can be prepared by Williamson synthesis in which an alkyl halide is reacted with sodium alkoxide. Di-*tert*-butyl ether can't be prepared by this method. Explain.

**Ans.** In order to prepare di-*tert*-butyl ether, sodium *tert*-butoxide must be reacted with *tert*-butyl bromide. Alkoxides are not only nucleophiles but they are strong base as well. They react with 3° alkyl halides leading to the elimination reaction.

When *tert*-butyl-bromide reacts with sodium *tert*-butoxide instead of substitution, elimination takes place. As a result of this elimination reaction, *iso* butylene is formed instead of di-*tert* butyl ether.

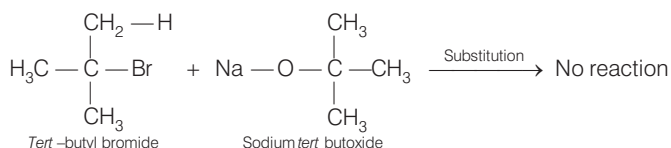
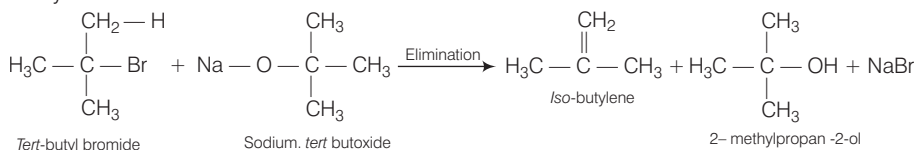

**Q. 51** Why is the C—O—H bond angle in alcohols slightly less than the tetrahedral angle whereas the C—O—C bond angle in ether is slightly greater?

### Thinking Process

To solve this question, it should keep in mind that the order of repulsion between electron pairs is  $\rightarrow lp - lp > lp - bp > bp - bp$ .

**Ans.** The bond angle in C— $\overset{\cdot\cdot}{\underset{\cdot\cdot}{\text{O}}}$ —H in alcohols is slightly less than tetrahedral angle ( $109^\circ 28'$ ). It is due to the repulsion between the unshared electron pairs of oxygen. In alcohols, two lone pair of electrons are present. Therefore, there is comparatively more repulsion and less bond angle.

The C—O—C bond angle in ether is slightly greater than the tetrahedral angle due to the repulsive interaction between the two bulky (*R*) groups.

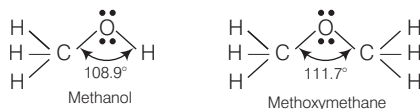

**Q. 52** Explain why low molecular mass alcohols are soluble in water?

**Ans.** Solubility of alcohols and phenols in water is due to their ability to form hydrogen bonds with water molecule. The hydrocarbon part methoxy methane (*i.e.*, *R* group) tends to prevent the formation of hydrogen bonds.

Alcohols with lower molar mass will have smaller hydrocarbon part and therefore tendency to form hydrogen bonding is more and they are more soluble in water.

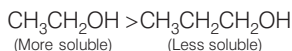

**Q. 53** Explain why *p*-nitrophenol is more acidic than phenol?

**Ans.** Nitro group of phenol produces  $-I$  and  $-R$  effect. Because of these two effects  $-\text{NO}_2$  group is electron withdrawing in nature. So, the electron density in the  $\text{O}-\text{H}$  bond of *p*-nitrophenol decreases relative to the  $\text{O}-\text{H}$  bond of phenol.

The decrease in electron density of the  $\text{O}-\text{H}$  bond of *p*-nitrophenol, the polarity of  $\text{O}-\text{H}$  bond is decrease and in turn make it more acidic than phenol.

**Q. 54** Explain why alcohols and ethers of comparable molecular mass have different boiling points?

**Ans.** Boiling point depends upon the strength of intermolecular forces of attraction. Higher these forces of attraction, more will be the boiling point. Alcohols undergo intermolecular hydrogen bonding. So, the molecules of alcohols are held together by strong intermolecular forces of attraction.

But in ethers no hydrogen atom is bonded to oxygen. Therefore, ethers are held together by weak dipole-dipole forces, not by strong hydrogen bond.

Since, lesser amount of energy is required than to break weak dipole-dipole forces in ethers than to break strong hydrogen bonds in alcohol.

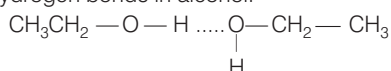

Hydrogen bond in alcohols

**Q. 55** The carbon-oxygen bond in phenol is slightly stronger than that in methanol. Why ?

**Ans.** Positive resonance effect is observed in phenols. Due to this  $+R$  effect, lone pair of electrons of  $-\text{OH}$  group are in conjugation with  $\pi$  electrons of the ring and the following resonance hybrid are obtained.

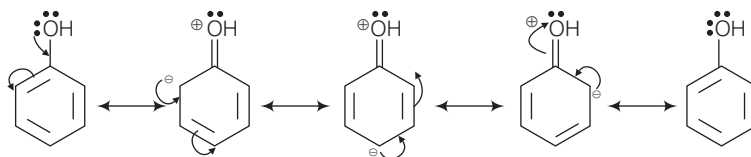

From the above resonating structure, it is very clear that  $\text{C}-\text{O}$  bond of phenol acquires some partial double bond character while the  $\text{C}-\text{O}$  bond of methanol is purely single bond. Therefore, the carbon-oxygen bond in phenol is slightly stronger than that in methanol.

**Q. 56** Arrange water, ethanol and phenol in increasing order of acidity and give reason for your answer.

**Ans.** The phenoxide ion obtained after the removal of a proton is resonance stabilised as follows

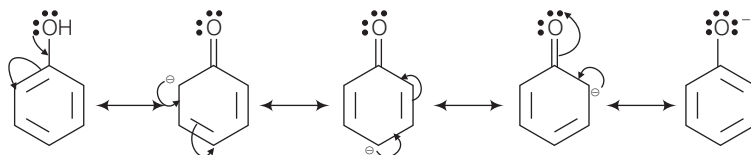

Whereas, the ethoxide ion obtained after the removal of a proton is not stabilised but destabilised due to +I effect of  $-\text{C}_2\text{H}_5$  group. Therefore, phenol is a stronger acid than ethanol. +I effect of  $\text{CH}_3-\text{CH}_2$  group increase the electron density on O—H bond in ethanol. As the electron density on the O—H bond of ethanol is more than that of water. So, ethanol is a weaker acid than water. Thus, the increasing order of acidity is  
ethanol < water < phenol

## Matching The Columns

**Q. 57** Match the structures of the compounds given in Column I with the name of the compounds given in Column II.

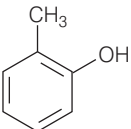
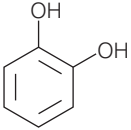
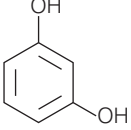
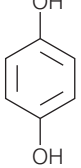
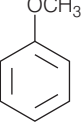
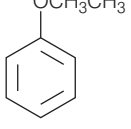
	Column I	Column II
A.		1. Hydroquinone
B.		2. Phenetole
C.		3. Catechol
D.		4. o-cresol
E.		5. Quinone
F.		6. Resorcinol
		7. Anisole

**Ans. A.** → (4)    **B.** → (3)    **C.** → (6)    **D.** → (1)    **E.** → (7)    **F.** → (2)

- A. Cresols are organic compounds which are methyl phenols. There are three forms of cresol-*o*-cresol, *p*-cresol and *m*-cresol.
- B. Catechol is also known as pyrocatechol. Its IUPAC name is 1, 2- dihydrobenzene. It is used in the production of pesticides, perfumes and pharmaceuticals.
- C. Its IUPAC name is 1, 3- dihydroxybenzene. Resorcinol is used to treat acne, seborrheic dermatitis and other skin disorder.
- D. Hydroquinone is also known as quinol. Its IUPAC name is 1, 4- dihydroxybenzene. It is a white granular solid. It is a good reducing agent.
- E. Anisole or methoxy benzene, is a colourless liquid with a smell reminiscent of anise seed.
- F. Phenetole is an organic compound. It is also known as ethylphenyl ether. It is volatile in nature and its vapours are explosive in nature.

**Q. 58** Match the starting material given in Column I with the products formed by these (Column II) in the reaction with HI.

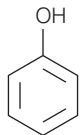
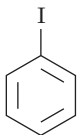
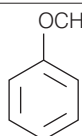
Column I	Column II
A. $\text{CH}_3\text{—O—CH}_3$	1.  + $\text{CH}_3\text{I}$
B. $\begin{array}{c} \text{CH}_3 \\ \diagup \\ \text{CH—O—CH}_3 \\ \diagdown \\ \text{CH}_3 \end{array}$	2. $\begin{array}{c} \text{CH}_3 \\   \\ \text{CH}_3\text{—C—I} + \text{CH}_3\text{OH} \\   \\ \text{CH}_3 \end{array}$
C. $\begin{array}{c} \text{CH}_3 \\   \\ \text{H}_3\text{C—C—O—CH}_3 \\   \\ \text{CH}_3 \end{array}$	3.  + $\text{CH}_3\text{OH}$
D. 	4. $\text{CH}_3\text{—OH} + \text{CH}_3\text{I}$
	5. $\begin{array}{c} \text{CH}_3 \\ \diagup \\ \text{CH—OH} + \text{CH}_3\text{I} \\ \diagdown \\ \text{CH}_3 \end{array}$
	6. $\begin{array}{c} \text{CH}_3 \\ \diagup \\ \text{CH—I} + \text{CH}_3\text{OH} \\ \diagdown \\ \text{CH}_3 \end{array}$
	7. $\begin{array}{c} \text{CH}_3 \\   \\ \text{CH}_3\text{—C—OH} + \text{CH}_3\text{I} \\   \\ \text{CH}_3 \end{array}$

**Ans. A.** → (4)    **B.** → (5)    **C.** → (2)    **D.** → (1)

A.  $\text{CH}_3 - \text{O} - \text{CH}_3$  is a symmetrical ether so the products are  $\text{CH}_3\text{I}$  and  $\text{CH}_3\text{OH}$ .

B. In  $(\text{CH}_3)_2\text{CH} - \text{O} - \text{CH}_3$  unsymmetrical ether, one alkyl group is primary while another is secondary. So, it follows  $\text{S}_{\text{N}}^2$  mechanism. Thus, the halide ion attacks the smaller alkyl group and the products are



C. In this case, one of the alkyl group is tertiary and the other is primary. It follows  $\text{S}_{\text{N}}^1$  mechanism and halide ion attacks the tertiary alkyl group and the products are  $(\text{CH}_3)_3\text{C} - \text{I}$  and  $\text{CH}_3\text{OH}$ .

D. Here, the unsymmetrical ether is alkyl aryl ether. In this ether  $\text{O} - \text{CH}_3$  bond is weaker than  $\text{O} - \text{C}_6\text{H}_5$  bond which has partial double bond character due to resonance. So, the halide ion attacks on alkyl group and the products are  $\text{C}_6\text{H}_5 - \text{OH}$  and  $\text{CH}_3\text{I}$ .

**Q. 59** Match the items of Column I with items of Column II.

Column I	Column II
A. Antifreeze used in car engine	1. Neutral ferric chloride
B. Solvent used in perfumes	2. Glycerol
C. Starting material for picric acid	3. Methanol
D. Wood spirit	4. Phenol
E. Reagent used for detection of phenolic group	5. Ethylene glycol
F. By product of soap industry used in cosmetics	6. Ethanol

**Ans. A.** → (5)    **B.** → (6)    **C.** → (4)    **D.** → (3)    **E.** → (1)    **F.** → (2)

A. IUPAC name of ethylene glycol is ethane -1, 2 - diol. It is primarily used as raw material in the manufacturing of polyester fibers and fabric industry. A small percentage of it is used in antifreeze formulations.

B. Ethanol is a good solvent for fatty and waxy substances. Fats and waxes provide odour to the perfumes. Apart from being a good solvent, it is less irritating to the skin. So, it is used in perfumes.

C. Phenol is converted into picric acid (2, 4, 6-trinitro-phenol) by the reaction of phenol with conc.  $\text{HNO}_3$ .

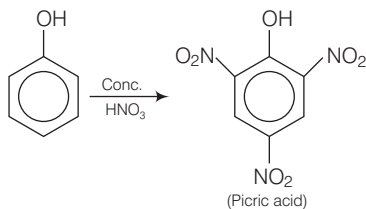

D. Methanol,  $\text{CH}_3\text{OH}$  is also known as 'wood spirit' as it was produced by the destructive distillation of wood.

E. Neutral ferric chloride give purple/red colour when treated with phenols. It is the reagent used for detection of phenolic group.

F. Soaps are prepared by the reactions of fatty acid with NaOH.

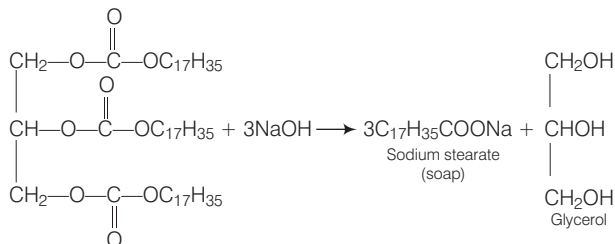

This glycerol (propan -1, 2, 3 - triol) is the by product of soap industry and used in cosmetics.

**Q. 60** Match the items of Column I with items of Column II.

Column I	Column II
A. Methanol	1. Conversion of phenol to <i>o</i> -hydroxysalicylic acid
B. Kolbe's reaction	2. Ethyl alcohol
C. Williamson's synthesis	3. Conversion of phenol to salicylaldehyde
D. Conversion of 2° alcohol to ketone	4. Wood spirit
E. Reimer-Tiemann reaction	5. Heated copper at 573K
F. Fermentation	6. Reaction of alkyl halide with sodium alkoxide

**Ans. A.** → (4)    **B.** → (1)    **C.** → (6)    **D.** → (5)    **E.** → (3)    **F.** → (2)

A. Methanol is also known as 'wood spirit' as it was produced by the destructive distillation of wood.

B. In Kolbe's reaction, 2 - hydroxy benzoic acid (salicylic acid) is prepared by the reaction of phenol with CO<sub>2</sub> gas.

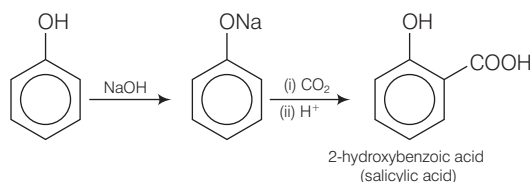

C. Williamson synthesis is an important method for the preparation of ethers. In this method, an alkyl halide is allowed to react with sodium alkoxide.

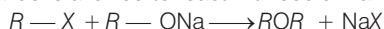

D. When a 2° alcohol is allowed to pass over heated copper at 573 K, dehydrogenation takes place and a ketone is formed.

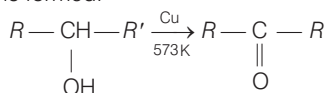



- E. On treating phenol with chloroform in the presence of NaOH, an aldehydic group is introduced at *ortho* position of benzene ring

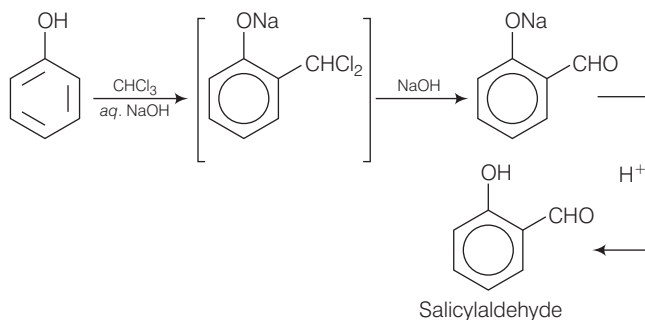

- F. Ethanol is prepared by the fermentation of sugars.

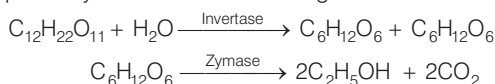

## Assertion and Reason

In the following questions a statement of Assertion (A) followed by a statement of Reason (R) is given. Choose the correct answer out of the following choices.

- Assertion and reason both are correct and reason is correct explanation of assertion.
- Assertion and reason both are wrong statements.
- Assertion is correct statement but reason is wrong statement.
- Assertion is wrong statement but reason is correct statement.
- Both assertion and reason are correct statements but reason is not correct explanation of assertion.

**Q. 61 Assertion (A)** Addition reaction of water to but-1-ene in acidic medium yields butan-1-ol.

**Reason (R)** Addition of water in acidic medium proceeds through the formation of primary carbocation.

**Ans. (b)** Assertion and reason both are wrong statements.

**Correct Assertion** Addition reaction of water to but-1-ene in acidic medium yields butan-2-ol.

**Correct Reason** Addition of water in acidic medium proceeds through the formation of secondary carbocation.



**Q. 65 Assertion (A)** Boiling points of alcohols and ethers are high.

**Reason (R)** They can form intermolecular hydrogen-bonding.

**Ans. (b)** Assertion and reason both are wrong statements.

**Correct Assertion** Boiling points of alcohols are higher than that of ethers of comparable molecular mass.

**Correct Reason** Alcohols can form intermolecular hydrogen bonding while ethers cannot.

**Q. 66 Assertion (A)** Like bromination of benzene, bromination of phenol is also carried out in the presence of Lewis acid.

**Reason (R)** Lewis acid polarises the bromine molecule.

**Ans. (d)** Assertion is wrong statement but reason is correct statement.

**Correct Assertion** Bromination of benzene but not of phenol is carried out in presence of a Lewis acid.

**Q. 67 Assertion (A)** *o*-nitrophenol is less soluble in water than the *m* and *p*-isomers.

**Reason (R)** *m* and *p*-nitrophenols exist as associated molecules.

**Ans. (d)** Both assertion and reason are correct statements but reason is not correct explanation of assertion.

**Correct Explanation** Due to the presence of intramolecular hydrogen bonding, *o*-nitrophenol does not form hydrogen bonds with  $H_2O$  but *m* and *p*-nitrophenol form hydrogen bonds with water.

**Q. 68 Assertion (A)** Ethanol is a weaker acid than phenol.

**Reason (R)** Sodium ethoxide may be prepared by the reaction of ethanol with aqueous NaOH.

**Ans. (c)** Assertion is correct statement but reason is wrong statement.

**Correct Reason** Phenoxide ion is stabilised by resonance but ethoxide ion is not stabilised by resonance.

Resonance in phenoxide ion

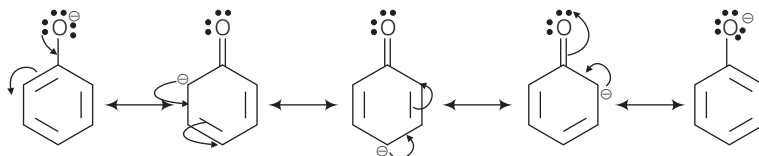

**Q. 69 Assertion (A)** Phenol forms 2, 4, 6-tribromophenol on treatment with  $Br_2$  in carbon disulphide at 273K.

**Reason (R)** Bromine polarises in carbon disulphide.

**Ans. (b)** Assertion and reason both are wrong statements.

**Correct Assertion** Phenol form 2, 4, 6-tribromophenol on treatment with bromine in water.

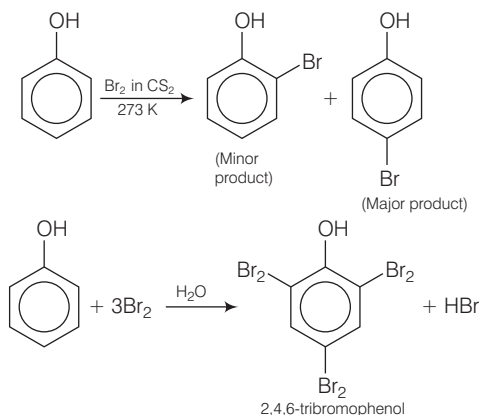

**Correct Reason** In water, phenol gives phenoxide ion. This phenoxide ion activates the ring towards electrophilic substitution reaction.

**Q. 70 Assertion** (A) Phenols give *o*- and *p*-nitrophenol on nitration with conc.  $\text{HNO}_3$  and  $\text{H}_2\text{SO}_4$  mixture.

**Reason (R)**  $-\text{OH}$  group in phenol is *o*-,*p*-directing.

**Ans. (d)** Assertion is wrong statement but reason is correct statement.

**Correct Assertion** Phenols give *o* and *p*-nitrophenol on nitration with dil.  $\text{HNO}_3$  at 298 K.

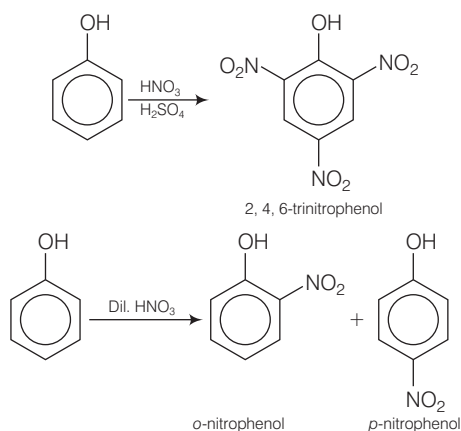

## Long Answer Type Questions

**Q. 71** Write the mechanism of the reaction of HI with methoxybenzene.

**Ans.** In case of alkyl aryl ethers, the products are always phenol and an alkyl halide because due to resonance  $C_6H_5 - O$  bond has partial double bond character. The mechanism is given below

**Mechanism** Protonation of anisole gives methylphenyl oxonium ion.

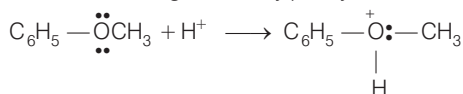

In this ion, the bond between  $O - CH_3$  is weaker than the bond between  $O - C_6H_5$  which has partial double bond character. This partial double bond character is due to the resonance between the lone pair of electrons on the O-atom and the  $sp^2$  hybridised carbon atom of the phenyl group. Therefore, attack by  $I^-$  ion exclusively breaks the weaker  $O - CH_3$  bond forming methyl iodide and phenol.

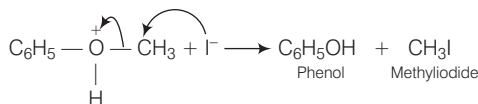

**Q. 72** (a) Name the starting material used in the industrial preparation of phenol.

(b) Write complete reaction for the bromination of phenol in aqueous and non-aqueous medium.

(c) Explain why Lewis acid is not required in bromination of phenol?

**Ans.** (a) The starting material used in the industrial preparation of phenol is cumene.

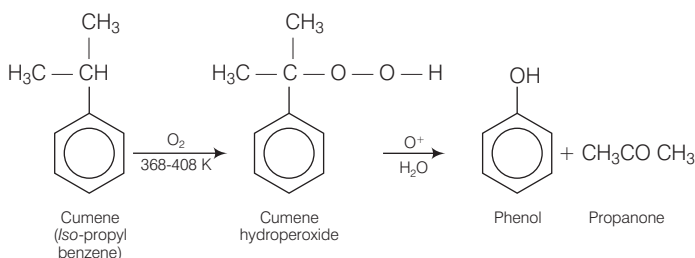

(b) Phenols when treated with bromine water gives polyhalogen derivatives in which all the hydrogen atoms present at *ortho* and *para* positions with respect to  $-OH$  group are replaced by bromine atoms.

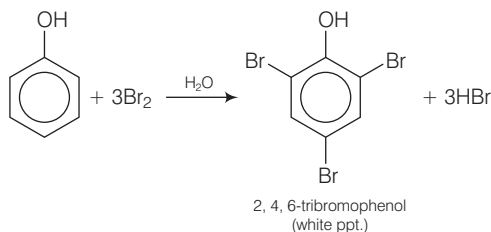

However, in non-aqueous medium such as  $\text{CS}_2$ ,  $\text{CCl}_4$ ,  $\text{CHCl}_3$ , monobromophenols are obtained.

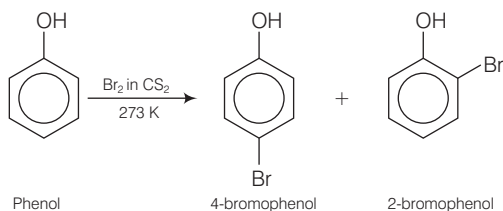

In aqueous solution, phenol ionises to form phenoxide ion. This ion activates the benzene ring to a very large extent and hence the substitution of halogen takes place at all three positions.

On the other hand, in non-aqueous solution ionisation of phenol is greatly suppressed. Therefore, ring is activated slightly and hence monosubstitution occur.

- (c) Lewis acid is an electron deficient molecule. In bromination of benzene, Lewis acid is used to polarise  $\text{Br}_2$  to form  $\text{Br}^+$  electrophile.

In case of phenol, oxygen atom of phenol itself polarises the bromine molecule to form  $\text{Br}^+$  ion (electrophile). So, Lewis acid is not required in the bromination of phenol.

#### Mechanism of bromination of phenol

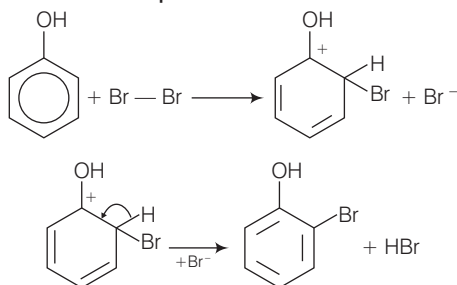

#### Mechanism of bromination of benzene

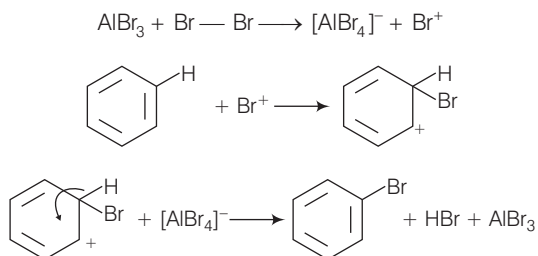

**Q. 73** How can phenol be converted to aspirin?

**Ans.** Phenol is converted into salicylic acid. This salicylic acid is treated with acetic anhydride. On acetylation of salicylic acid, aspirin (acetyl salicylic acid) is formed.

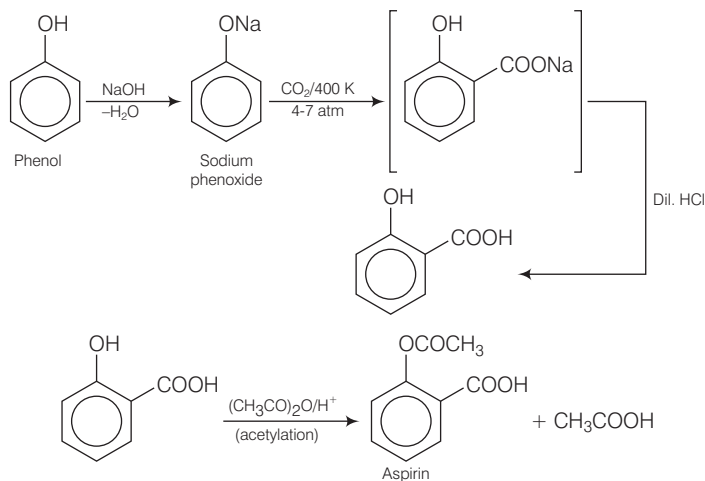
**Q. 74** Explain a process in which a biocatalyst is used in industrial preparation of a compound known to you.

**Ans.** Enzymes are biocatalyst. These biocatalysts (enzymes) are used in the industrial preparation of ethanol. Ethanol is prepared by the fermentation of molasses - a dark brown coloured syrup left after crystallisation of sugar which still contains about 40% of sugar.

The process of fermentation actually involves breaking down of large molecules into simple ones in the presence of enzymes. The source of these enzymes is yeast. The various reactions taking place during fermentation of carbohydrates are

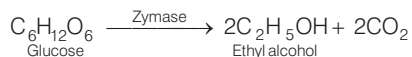
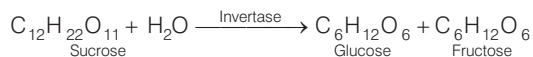

In wine making, grapes are the source of sugars and yeast. As grapes ripen, the quantity of sugar increases and yeast grows on the outer skin. When grapes are crushed, sugar and the enzyme come in contact and fermentation starts. Fermentation takes place in anaerobic conditions *i.e.*, in absence of air. CO<sub>2</sub> gas is released during fermentation.

The action of zymase is inhibited once the percentage of alcohol formed exceeds 14 per cent. If air gets into fermentation mixture, the oxygen of air oxidises ethanol to ethanoic acid which in turn destroys the taste of alcoholic drinks.

# Aldehyde, Ketones and Carboxylic Acids

## Multiple Choice Questions (MCQs)

**Q. 1** Addition of water to alkynes occurs in acidic medium and in the presence of  $\text{Hg}^{2+}$  ions as a catalyst. Which of the following products will be formed on addition of water to but-1-yne under these conditions?

- (a)  $\text{CH}_3\text{—CH}_2\text{—CH}_2\text{—C(=O)—H}$       (b)  $\text{CH}_3\text{—CH}_2\text{—C(=O)—CH}_3$   
 (c)  $\text{CH}_3\text{—CH}_2\text{—C(=O)—OH} + \text{CO}_2$       (d)  $\text{CH}_3\text{—C(=O)—OH} + \text{H—C(=O)—H}$

**Ans. (b)** But-1-yne on reaction with water in presence of  $\text{Hg}^{2+}$  ions as a catalyst produces butan-2-one.

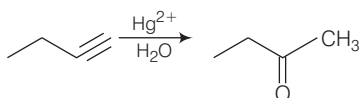

**Mechanism**

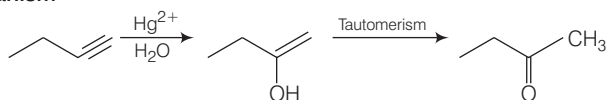

**Q. 2** Which of the following compounds is most reactive towards nucleophilic addition reactions?

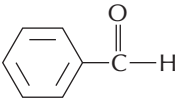
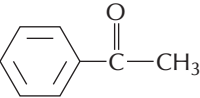
- (a)  $\text{CH}_3\text{—C(=O)—H}$       (b)  $\text{CH}_3\text{—C(=O)—CH}_3$   
 (c)       (d) 



**Ans. (a)** Reactivity of carbonyl compounds can be decided by two factors

- (i) **Steric factor** Lesser the steric factor greater will be its reactivity.  
 (ii) **Electronic factor** Greater the number of alkyl group lesser will be its electrophilicity.

Hence,  $\text{CH}_3\text{—CHO}$  is most reactive towards nucleophilic addition reaction.

**Q. 3** The correct order of increasing acidic strength is .....

- (a) phenol < ethanol < chloroacetic acid < acetic acid  
 (b) ethanol < phenol < chloroacetic acid < acetic acid  
 (c) ethanol < phenol < acetic acid < chloroacetic acid  
 (d) chloroacetic acid < acetic acid < phenol < ethanol

**Ans. (c)** Phenol is more stable than alcohol due to formation of more stable conjugate base after removal of  $\text{H}^+$  from phenol.

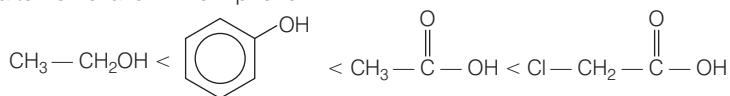

On the other hand, carboxylic acid is more acidic than phenol due to formation of more stable conjugate base after removal of  $\text{H}^+$  as compared to phenol.

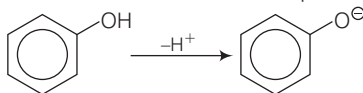

Chloroacetic acid is more acidic than acetic acid due to the presence of electron withdrawing chlorine group attached to  $\alpha$ -carbon of carboxylic acid.

Hence, correct choice is (c).

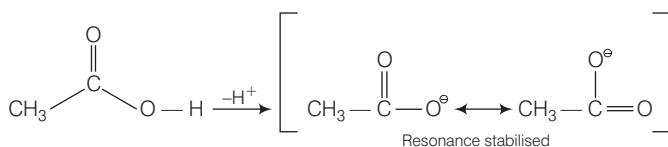

**Q. 4** Compound  $\text{Ph—O—C(=O)—Ph}$  can be prepared by the reaction of .....

- (a) phenol and benzoic acid in the presence of  $\text{NaOH}$   
 (b) phenol and benzoyl chloride in the presence of pyridine  
 (c) phenol and benzoyl chloride in the presence of  $\text{ZnCl}_2$   
 (d) phenol and benzaldehyde in the presence of palladium

**Ans. (b)** Compound  $\text{Ph—COO—Ph}$  can be prepared by the reduction of

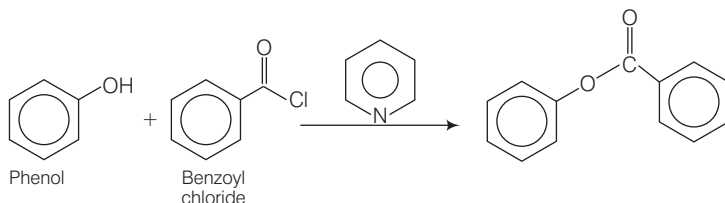

This is an example of **Schotten-Baumann reaction**.



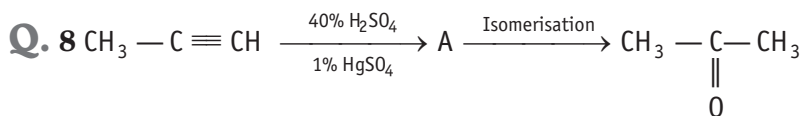

Structure of 'A' and type of isomerism in the above reaction are respectively

- (a) Prop-1-en-2-ol, metamerism
- (b) Prop-1-en-1-ol, tautomerism
- (c) Prop-2-en-2-ol, geometrical isomerism
- (d) Prop-1-en-2-ol, tautomerism

**Ans. (d)** Chemical reaction can be shown as

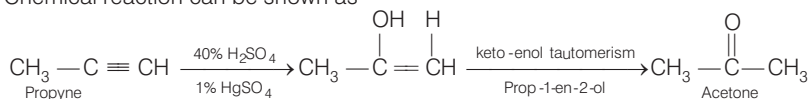

[A] is prop-1-en-2-ol, which undergo tautomerism to form acetone.

**Q. 9** Compounds A and C in the following reaction are .....

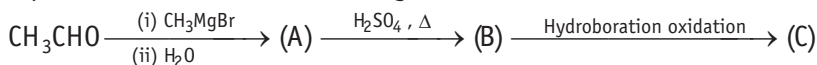

- (a) identical
- (b) positional isomers
- (c) functional isomers
- (d) optical isomers

**Ans. (b)** Chemical reaction can be shown as

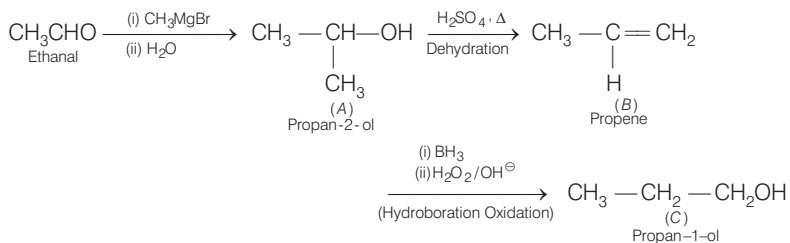

Thus,  $\text{CH}_3\text{CH}(\text{OH})\text{CH}_3$  and  $\text{CH}_3\text{CH}_2\text{CH}_2\text{OH}$  are positional isomers.

Hence, option (b) is correct.

**Q. 10** Which is the most suitable reagent for the following conversion?

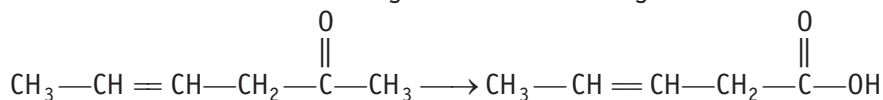

- (a) Tollen's reagent
- (b) Benzoyl peroxide
- (c)  $\text{I}_2$  and NaOH solution
- (d) Sn and NaOH solution

**Ans. (c)** Iodoform test is used to test presence of  $-\text{COCH}_3$  group which is converted into  $-\text{COOH}$  group.

The reaction is shown as

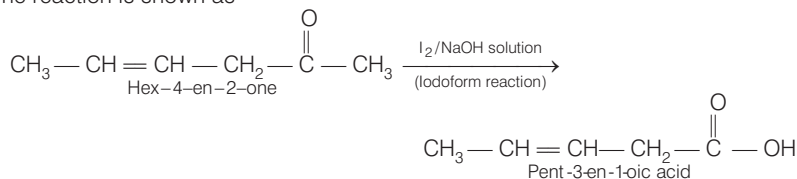

**Q. 11** Which of the following compounds will give butanone on oxidation with alkaline  $\text{KMnO}_4$  solution?

- (a) Butan-1-ol (b) Butan-2-ol  
 (c) Both (a) and (b) (d) None of these

**Ans. (b)** Butan-2-ol on oxidation with alkaline  $\text{KMnO}_4$  solution produces butanone as follows

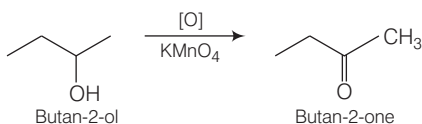

**Q. 12** In Clemmensen reduction, carbonyl compound is treated with .....

- (a) zinc amalgam + HCl  
 (b) sodium amalgam + HCl  
 (c) zinc amalgam + nitric acid  
 (d) sodium amalgam +  $\text{HNO}_3$

**Ans. (a)** Clemmensen reduction is used to convert carbonyl group to  $\text{CH}_2$  group as follows

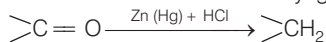

Zinc amalgam and HCl act as reagent in this reaction.

## Multiple Choice Questions (More Than One Options)

**Q. 13** Which of the following compounds do not undergo aldol condensation?

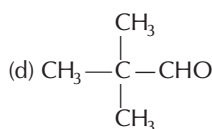
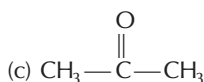
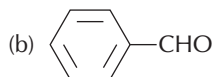
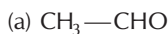

**Ans. (b, d)**

Necessary condition for aldol condensation is the presence of at least one  $\alpha$ -H-atom.

Hence,  $\text{C}_6\text{H}_5\text{CHO}$  and  $(\text{CH}_3)_3\text{CCHO}$  do not undergo aldol condensation as the both do not have any  $\alpha$ -hydrogen atom.

**Q. 14** Treatment of compound  $\text{Ph}-\text{O}-\overset{\text{O}}{\parallel}{\text{C}}-\text{Ph}$  with NaOH solution yields

- (a) phenol
- (b) sodium phenoxide
- (c) sodium benzoate
- (d) benzophenone

**Ans. (b, c)**

Treatment of compound  $\text{Ph}-\text{O}-\overset{\text{O}}{\parallel}{\text{C}}-\text{Ph}$  with NaOH yields sodium phenoxide and sodium benzoate by means of nucleophilic substitution reaction as follows

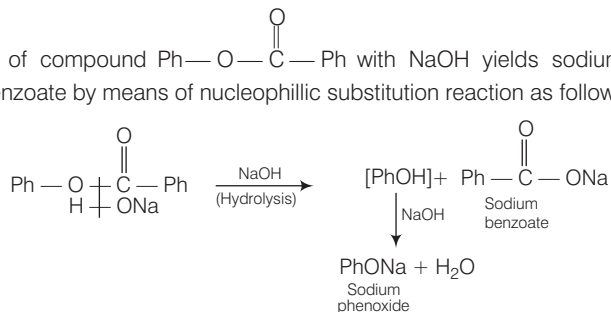

**Q. 15** Which of the following conversions can be carried out by Clemmensen reduction?

- (a) Benzaldehyde into benzyl alcohol
- (b) Cyclohexanone into cyclohexane
- (c) Benzoyl chloride into benzaldehyde
- (d) Benzophenone into diphenyl methane

**Ans. (b, d)**

Clemmensen reduction is used to convert cyclohexanone into cyclohexane and benzophenone into diphenyl methane as follows

Reagent used in Clemmensen reduction is zinc amalgam in hydrochloric acid, i.e., Zn(Hg) in HCl.

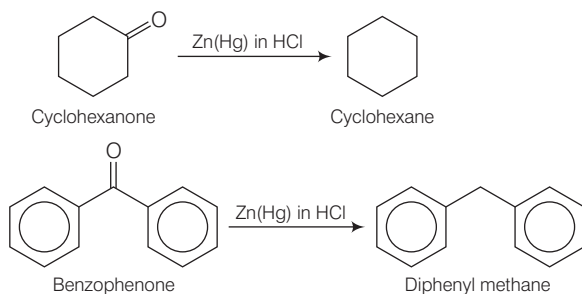

**Q. 16** Through which of the following reactions number of carbon atoms can be increased in the chain?

- (a) Grignard reaction
- (b) Cannizzaro's reaction
- (c) Aldol condensation
- (d) HVZ reaction

**Ans. (a, c)**

Grignard reaction and aldol condensation is used to increase the number of carbon atom in the chain as follows

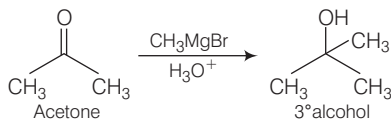
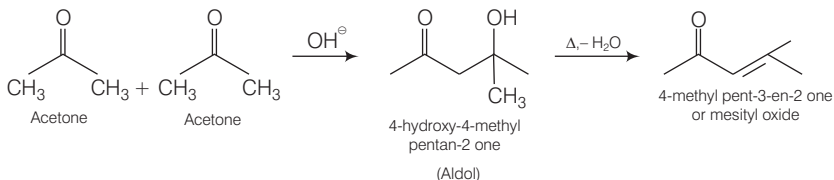
**Grignard reaction****Aldol condensation**

While other two reactions Cannizzaro reaction and HVZ reaction don't lead to increase in number of carbon atom.

**Q. 17** Benzophenone can be obtained by .....

- benzoyl chloride + benzene +  $\text{AlCl}_3$
- benzoyl chloride + diphenyl cadmium
- benzoyl chloride + phenyl magnesium chloride
- benzene + carbon monoxide +  $\text{ZnCl}_2$

**Ans. (a, b)**

(a) Benzophenone can be obtained by Friedel-Craft acylation reaction. The reaction is shown as

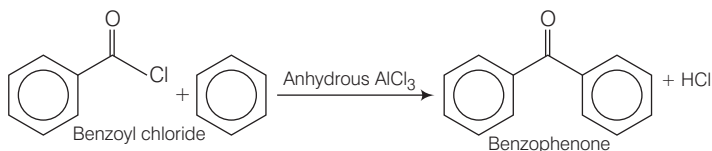

(b) Benzophenone can also be obtained by the reaction between benzoyl chloride and diphenyl cadmium.

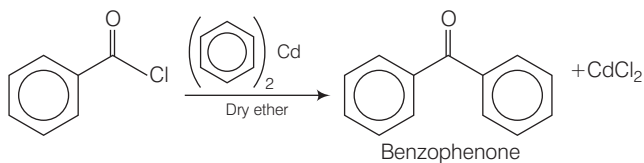

**Q. 18** Which of the following is the correct representation for intermediate of nucleophilic addition reaction to the given carbonyl compound (A)?

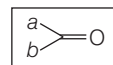

(A)

- 
- 
- 
-

**Ans. (a, b)**

Since, carbonyl compound is a planar molecule hence two orientation of molecule regarding attack of nucleophile is possible as follows

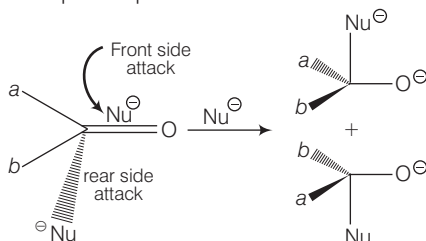

Since, the product contains a chiral carbon, therefore, attack of nucleophile can occur either from front side attack or rear side attack giving enantiomeric products. Hence, (a) and (b) are the correct choices.

## Short Answer Type Questions

**Q. 19** Why is there a large difference in the boiling points of butanal and butan-1-ol?

### 💡 Thinking Process

This problem based upon the concept of H-bonding which is used in determination of boiling point.

**Ans.** Butan-1-ol has intermolecular H-bonding as shown below

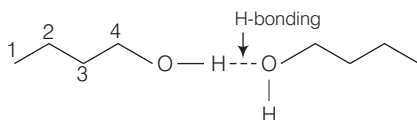

Intermolecular H.-bonding in butan-1-ol

Butanol has polar  $\text{O}-\text{H}$  bond due to which it shows intermolecular H-bonding which is not possible in case of butanal due to absence of polar bond. Instead of it has only weak dipole-dipole interactions. Hence, butanal has higher boiling point than butan-1-ol.

**Q. 20** Write a test to differentiate between pentan-2-one and pentan-3-one.

### 💡 Thinking Process

This problem is based on the concept of iodoform test. The organic compound

containing  $\text{—}\overset{\text{O}}{\parallel}{\text{C}}\text{—CH}_3$  or  $\text{CH}_3\text{CH}(\text{OH})$  group which produces  $\text{CH}_3\text{CO}$  group on oxidation undergoes iodoform test.

**Ans. Iodoform test** (yellow ppt. formed when heated with sodium hypohalite) Pentan-2-one gives positive test as it contains  $\text{—COCH}_3$  group whereas pentan-3-one does not.

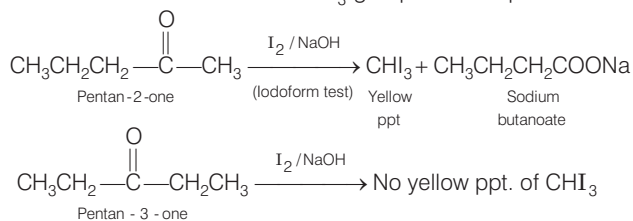

**Q. 21** Give the IUPAC names of the following compounds.

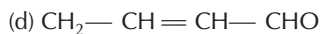
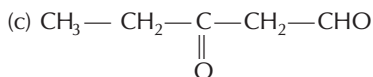
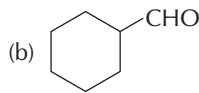
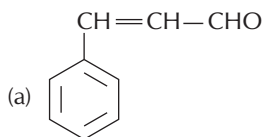

**Ans.** Following are the IUPAC names of the compounds

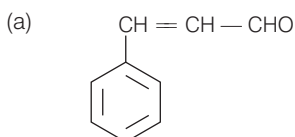

3-phenylprop-2-en-1-al

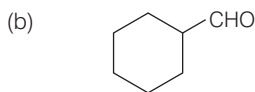

Cyclohexanecarbaldehyde

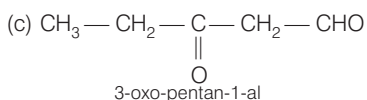

3-oxo-pentan-1-al

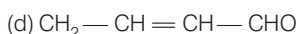

But-2-en-1-al

**Q. 22** Give the structure of the following compounds.

(a) 4-nitropropiophenone

(b) 2-hydroxycyclopentanecarbaldehyde

(c) Phenyl acetaldehyde

**Ans.** (a) 4-nitropropiophenone

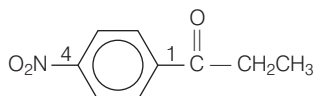

(b) 2-hydroxycyclopentanecarbaldehyde

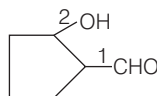

(c) Phenyl acetaldehyde

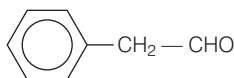

**Q. 23** Write IUPAC names of the following structures

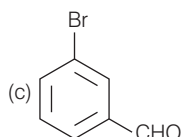
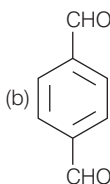



**Ans.** The IUPAC names of the following structures are

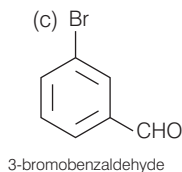
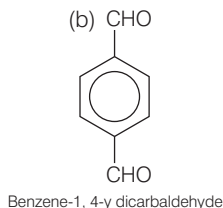
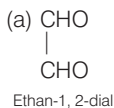

**Q. 24** Benzaldehyde can be obtained from benzal chloride. Write reactions for obtaining benzal chloride and then benzaldehyde from it.

**Ans.** It is the commercial method for preparing benzaldehyde. Benzal chloride can be obtained by photochlorination of toluene *i.e.*, chlorination of toluene in presence of sunlight. Then, benzal chloride on heating with boiling water produces benzaldehyde as shown below.

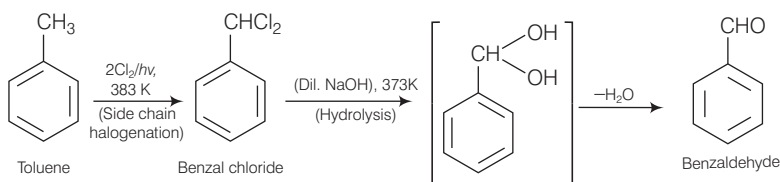

**Q. 25** Name the electrophile produced in the reaction of benzene with benzoyl chloride in the presence of anhydrous  $\text{AlCl}_3$ . Name the reaction also.

**Ans.** Benzene, on reaction with benzoyl chloride undergoes formation of benzophenone through intermediate benzylium cation.

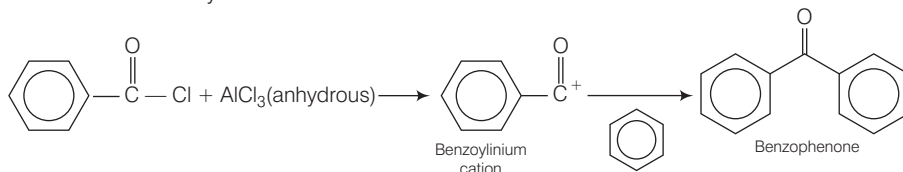

This is an example of Friedel-Craft acylation reaction.

**Q. 26** Oxidation of ketones involves carbon-carbon bond cleavage. Name the products formed on oxidation of 2, 5-dimethylhexan-3-one.

**Thinking Process**

This problem is based on concept of cleavage of C—C bond. According to **Popoff's rule**, during cleavage of unsymmetrical ketone, keto group stays preferentially with the smaller group.

**Ans.** According to Popoff's rule, the unsymmetrical ketone on oxidation, C—C bond cleavage

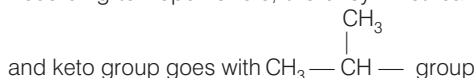

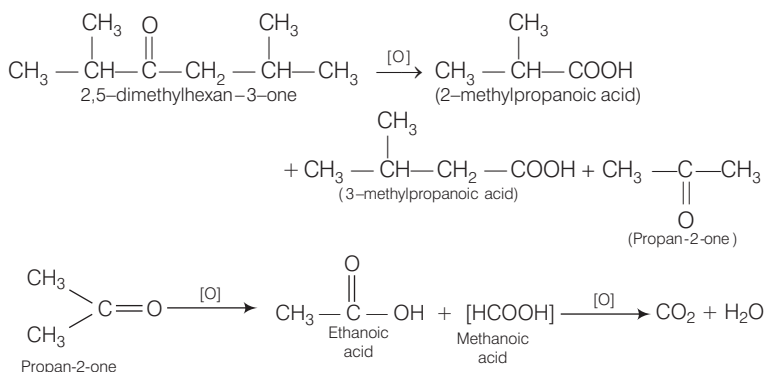

**Q. 27** Arrange the following in decreasing order of their acidic strength and give reason for your answer.



### Thinking Process

This problem based on the concept of acidic strength, inductive effect and conjugation.

- Presence of + I group decreases acidic strength.
- Presence of - I group increases acidic strength.

**Ans.**  $\text{FCH}_2\text{COOH} > \text{ClCH}_2\text{COOH} > \text{C}_6\text{H}_5\text{CH}_2\text{COOH} > \text{CH}_3\text{COOH} > \text{CH}_3\text{CH}_2\text{OH}$

### Reasons

- More the electron withdrawing nature of substituent, more is the acidic strength.
- Direct attachment of  $\text{C}_6\text{H}_5$  group increases acidity due to resonance and  $sp^2$  hybridisation.
- Alcohols are weakly acidic than carboxylic acids.

**Q. 28** What product will be formed on reaction of propanal with 2-methylpropanal in the presence of NaOH? What products will be formed? Write the name of the reaction also.

### Thinking Process

This problem based on the concept of cross aldol condensation.

**Ans.** It is an example of cross aldol condensation.

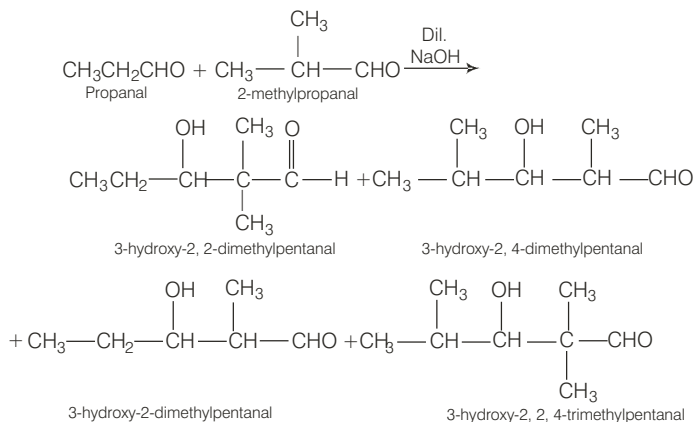

**Q. 29** Compound 'A' was prepared by oxidation of compound 'B' with alkaline  $\text{KMnO}_4$ . Compound 'A' on reduction with lithium aluminium hydride gets converted back to compound 'B'. When compound 'A' is heated with compound B in the presence of  $\text{H}_2\text{SO}_4$  it produces fruity smell of compound C to which family the compounds 'A', 'B' and 'C' belong to?

**Thinking Process**

*This problem includes conceptual mixing of preparation and properties of carboxylic acid and ester. Try to catch the key point of the process.*

**Ans.** Since, B and A on heating together in the presence of acid produces ester (a fruity smell).

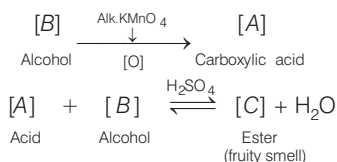

**Q. 30** Arrange the following in decreasing order of their acidic strength. Give explanation for the arrangement.



**Ans.** The decreasing order of their acidic strength

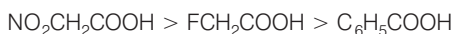

Acidic strength decreases as the number of electron withdrawing substituent(s) linked to  $\alpha$ -carbon atom or carboxylic group of carboxylic acid decreases. Electron withdrawing ability of  $\text{NO}_2$ , F and  $\text{C}_6\text{H}_5$  are as follows



**Q. 31** Alkenes  $\text{>C=C<}$  and carbonyl compounds  $\text{>C=O}$  both contain a  $\pi$  bond but alkenes show electrophilic addition reactions whereas carbonyl compounds show nucleophilic addition reactions. Explain.

**Ans.** Nature of chemical reaction occurring on  $\text{>C=C<}$  bond or  $\text{>C=O}$  bond can be explained on the basis of nature of bond between  $\text{>C=C<}$  and  $\text{>C=O}$ .

$\text{>C=C<}$   
Non-polar covalent  
compound

$\text{>C=O}$   
Polar covalent  
compound

- Due to electronegativity difference between carbon and oxygen

Thus, in  $\text{>C=O}$  carbon acquires partially positive charge and O acquires partially negative charge and show nucleophilic addition reaction to the electrophilic carbonyl carbon. On the other hand,  $\text{>C=C<}$  undergo electrophilic addition reaction due to nucleophilic nature of  $\text{>C=C<}$  which contains  $\pi$  bond.

**Q. 32** Carboxylic acids contain carbonyl group but do not show the nucleophilic addition reaction like aldehydes or ketones. Why?

**Ans.** Carboxylic acid contain carbonyl group but do not show nucleophilic addition reaction like aldehyde and ketone. Due to resonance as shown below the partial positive charge on carbonyl carbon atom is reduced.



**Q. 33** Identify the compounds A, B and C in the following reaction.

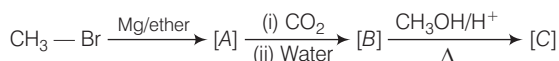

**Ans.** Complete chemical conversion can be done as

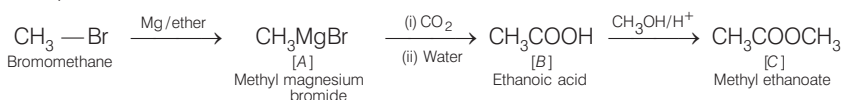

**Q. 34** Why are carboxylic acids more acidic than alcohols or phenols although all of them have hydrogen atom attached to a oxygen atom ( $-\text{O}-\text{H}$ )?

**Ans.** Carboxylic acids are more acidic than alcohol or phenol, although all of them have  $\text{O}-\text{H}$  bond. This can be explained on the basis of stability of conjugate base obtained after removal of  $\text{H}^+$  from acid or phenol.

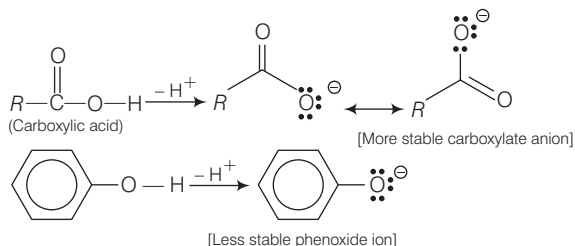

Hence, dissociation of  $\text{O}-\text{H}$  bond in case of carboxylic acid become easier than that of phenol. Hence, carboxylic acid are stronger acid than phenol.

**Q. 35** Complete the following reaction sequence.

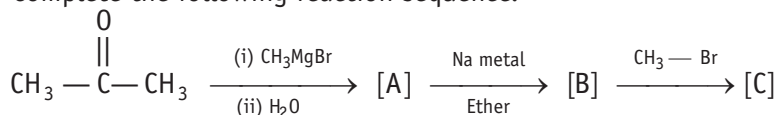

**Ans.** The complete chemical transformation can be shown as

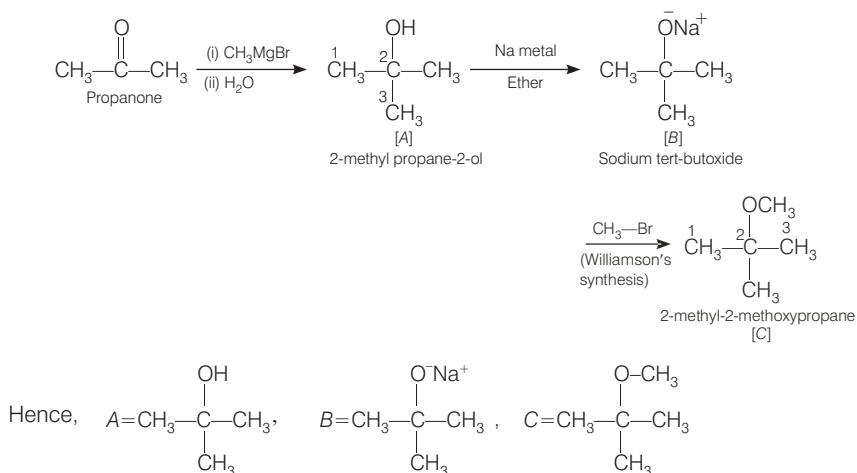

**Q. 36** Ethyl benzene is generally prepared by acetylation of benzene followed by reduction and not by direct alkylation. Think of a possible reason.

**Ans.** Preparation of ethyl benzene from acylation of benzene and reduction can be shown as

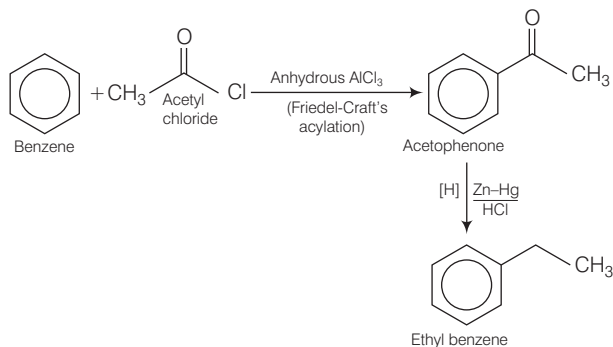

The direct alkylation can not be performed because there is polysubstitution product is formed. Due to disadvantage of polysubstitution that Friedel-Craft's alkylation reaction is not used for preparation of alkylbenzenes. Instead of Friedel-Craft's acylation is used.

**Q. 37** Can Gatterman-Koch reaction be considered similar to Friedel-Craft's acylation? Discuss.

**Ans.** In Gatterman-Koch reaction, benzene or its derivative is treated with CO and HCl in presence of anhydrous aluminium chloride to produce benzaldehyde.

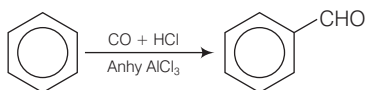

While in Friedel-Craft acylation, acyl group is transferred to carbon of benzene and acyl benzene is obtained as a result.

This can be done by reaction of benzene with acyl chloride in the presence of anhydrous  $\text{AlCl}_3$ .

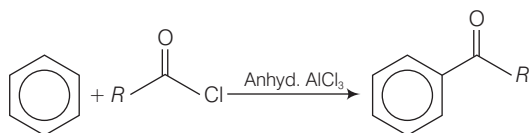

Formyl chloride is unstable in nature. So, it can be transferred by only Gattermann-Koch reaction not by Friedel-Craft reaction.

## Matching The Columns

**Q. 38** Match the common names given in Column I with the IUPAC names given in Column II.

Column I (Common names)	Column II (IUPAC names)
A. Cinnamaldehyde	1. Pentanal
B. Acetophenone	2. Prop-2-en-al
C. Valeraldehyde	3. 4-methylpent-3-en-2-one
D. Acrolein	4. 3-phenylprop-2-en-al
E. Mesityl oxide	5. 1-phenylethanone



**Ans. A.** → (4)    **B.** → (5)    **C.** → (1)    **D.** → (2)    **E.** → (3)

Common names	Structure	IUPAC names
A. Cinnamaldehyde		3-phenylprop-2-en-al
B. Acetophenone		1-phenylethanone
C. Valeraldehyde		Pentanal
D. Acrolein		Prop-2-en-al
E. Mesityl oxide		4-methyl pent-3-en-2-one

**Q. 39** Match the acids given in Column I with their correct IUPAC names given in Column II.

Column I (Acids)		Column II (IUPAC names)
A.	Phthalic acid	1. Hexane- 1, 6-dioic acid
B.	Oxalic acid	2. Benzene-1, 2-dicarboxylic acid
C.	Succinic acid	3. Pentane-1, 5-dioic acid
D.	Adipic acid	4. Butane-1, 4-dioic acid
E.	Glutaric acid	5. Ethane-1, 2-dioic acid

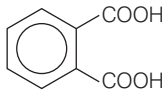
**Ans. A.** → (2)    **B.** → (5)    **C.** → (4)    **D.** → (1)    **E.** → (3)

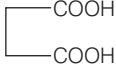
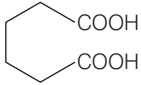
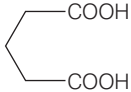
Acids	IUPAC names	Structure
A. Phthalic acid	Benzene-1, 2-dicarboxylic acid	
B. Oxalic acid	Ethane-1, 2-dioic acid	
C. Succinic acid	Butane-1, 4-dioic acid	
D. Adipic acid	Hexane- 1, 6-dioic acid	
E. Glutaric acid	Pentane-1, 5-dioic acid	

**Q. 40** Match the reactions given in Column I with the suitable reagents given in Column II.

Column I (Reactions)		Column II (Reagents)
A.	Benzophenone → Diphenylmethane	1. $\text{LiAlH}_4$
B.	Benzaldehyde → 1-phenylethanol	2. DIBAL-H
C.	Cyclohexanone → Cyclohexanol	3. $\text{Zn(Hg)/Conc. HCl}$
D.	Phenyl benzoate → Benzaldehyde	4. $\text{CH}_3\text{MgBr}$

Ans. A. → (3)    B. → (4)    C. → (1)    D. → (2)

	Reactions	Reagents
A.	<p style="text-align: center;">Benzophenone <math>\xrightarrow[\text{Conc. HCl}]{\text{Zn(Hg)}}</math> Diphenylmethane</p>	Zn(Hg)/Conc. HCl
B.	<p style="text-align: center;">Benzaldehyde <math>\xrightarrow[\text{H}_3\text{O}^+]{\text{CH}_3\text{MgBr}}</math> 1-phenylethanol</p>	$\text{CH}_3\text{MgBr}$
C.	<p style="text-align: center;">Cyclohexanone <math>\xrightarrow{\text{LiAlH}_4}</math> Cyclohexanol</p>	$\text{LiAlH}_4$
D.	<p style="text-align: center;">Phenyl benzoate <math>\xrightarrow[\text{H}_2\text{O}]{\text{DIBAL-H}}</math> benzaldehyde</p>	DIBAL-H

**Q. 41** Match the example given in Column I with the name of the reaction in Column II.

Column I (Example)	Column II (Reaction)
A. $\text{CH}_3-\overset{\text{O}}{\parallel}{\text{C}}-\text{Cl} + \text{H}_2 \xrightarrow{\text{Pd-C/BaSO}_4} \text{CH}_3-\overset{\text{O}}{\parallel}{\text{C}}-\text{H}$	1. Friedel-Crafts acylation
B.	2. HVZ reaction
C.	3. Aldol condensation



Column I (Example)	Column II (Reaction)
D. $R-CH_2-COOH \xrightarrow{Br_2/Red P} R-\underset{\substack{  \\ Br}}{CH}-COOH$	4. Cannizzaro's reaction
E. $CH_3-CN \xrightarrow[\text{(ii) } H_2O/H^+]{\text{(i) } SnCl_2/HCl} CH_3CHO$	5. Rosenmund's reduction
F. $2CH_3CHO \xrightarrow{NaOH} CH_3-CH=CHCHO$	6. Stephen's reaction

Ans. A. → (5)    B. → (4)    C. → (1)    D. → (2)    E. → (6)    F. → (3)

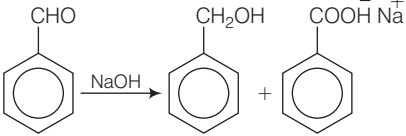
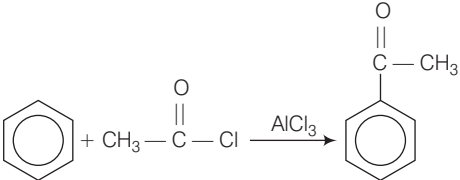
Example	Name of the reaction
A. $CH_3-\overset{O}{\parallel}{C}-Cl + H_2 \xrightarrow{Pd-C/BaSO_4} CH_3-\overset{O}{\parallel}{C}-H$	Rosenmund's reduction
B. 	Cannizzaro's reaction
C. 	Friedel-Crafts acylation
D. $R-CH_2-COOH \xrightarrow{Br_2/Red P} R-\underset{\substack{  \\ Br}}{CH}-COOH$	HVZ reaction
E. $CH_3-CN \xrightarrow[\text{(ii) } H_2O/H^+]{\text{(i) } SnCl_2/HCl} CH_3CHO$	Stephen's reaction
F. $2CH_3CHO \xrightarrow{NaOH} CH_3-CH=CHCHO$	Aldol condensation

## Assertion and Reason

In the following questions a statement of Assertion (A) followed by a statement of Reason (R) is given. Choose the correct answer out of the following choices.

- Assertion and reason both are correct and reason is correct explanation of assertion.
- Assertion and reason both are wrong statements.
- Assertion is correct statement but reason is wrong statement.
- Assertion is wrong statement but reason is correct statement.
- Assertion and reason both are correct statements but reason is not correct explanation of assertion.

**Q. 42 Assertion (A)** Formaldehyde is a planar molecule.  
**Reason (R)** It contains  $sp^2$  hybridised carbon atom.

**Ans. (a)** Assertion and reason are correct and reason is the correct explanation of assertion. Formaldehyde is planar molecule due to  $sp^2$  hybridised carbon atom.

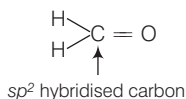

**Q. 43 Assertion (A)** Compounds containing  $-\text{CHO}$  group are easily oxidised to corresponding carboxylic acids.  
**Reason (R)** Carboxylic acids can be reduced to alcohols by treatment with  $\text{LiAlH}_4$ .

**Ans. (e)** Assertion and reason both are correct but reason is not the correct explanation of assertion.

Compounds containing  $-\text{CHO}$  group are easily oxidised to corresponding carboxylic acids. Correct reason is due to electron withdrawing nature of  $\text{C}=\text{O}$  group,  $\text{C}-\text{H}$  bond in aldehydes is weak and easily oxidised to the corresponding carboxylic acids even with mild oxidising agent like Fehling's solution and Tollen's reagents.

**Q. 44 Assertion (A)** The  $\alpha$ -hydrogen atom in carbonyl compounds is less acidic.

**Reason (R)** The anion formed after the loss of  $\alpha$ -hydrogen atom is resonance stabilised.

**Ans. (d)** Assertion is wrong statement but reason is correct statement.

Correct assertion is the  $\alpha$ -hydrogen atom in carbonyl compounds is acidic in nature due to presence of electron withdrawing carbonyl group. The anion formed after loss of  $\alpha$ -hydrogen atom is resonance stabilised.

**Q. 45 Assertion (A)** Aromatic aldehydes and formaldehyde undergo Cannizzaro reaction.

**Reason (R)** Aromatic aldehydes are almost as reactive as formaldehyde.

**Ans. (c)** Assertion is the correct statement but reason is the wrong statement.

Aromatic aldehyde and formaldehyde undergo Cannizzaro reaction due to absence of  $\alpha$ -H-atom lead to formation of carboxylic acid and alcohols of corresponding aldehyde.

**Q. 46 Assertion (A)** Aldehydes and ketones, both react with Tollen's reagent to form silver mirror.

**Reason (R)** Both, aldehydes and ketones contain a carbonyl group.

**Ans. (d)** Assertion is wrong statement but reason is the correct statement.

Aldehydes but not ketones react with Tollen's reagent to form silver mirror. Reason is correct statement as aldehyde and ketone both contain carbonyl group.

## Long Answer Type Questions

**Q. 47** An alkene 'A' (molecular formula  $C_5H_{10}$ ) on ozonolysis gives a mixture of two compounds 'B' and 'C'. Compound 'B' gives positive Fehling's test and also forms iodoform on treatment with  $I_2$  and NaOH. Compound 'C' does not give Fehling's test but forms iodoform. Identify the compounds A, B and C. Write the reaction for ozonolysis and formation of iodoform from B and C.

### Thinking Process

*This problem is based on conceptual mixing of preparation and properties of carbonyl compound including ozonolysis, iodoform test.*

*Only aldehyde (not ketone) undergo Fehling test.*

Compound containing  $\begin{array}{c} \text{O} \\ || \\ \text{—C—CH}_3 \end{array}$  group undergo iodoform test.

*Draw all possible structures of A using degree of unsaturation calculations then choose the correct structure using information provided above in the question.*

**Ans.** Molecular formula =  $C_5H_{10}$

$$\text{Degree of unsaturation} = (C_n + 1) - \frac{H_n}{2}$$

where,  $C_n$  = number of carbon atoms

$H_n$  = number of hydrogen atoms

$$= (5 + 1) - \frac{10}{2} = 1$$

Compound A will be either alkene or cyclic hydrocarbon. Since, A is undergoing ozonolysis hence A must be an alkene.

**Possible structures of alkene are**

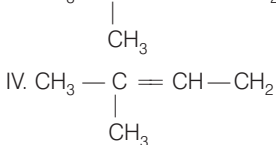
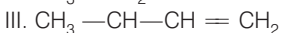
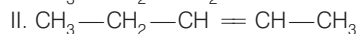
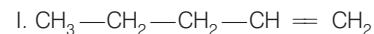

Ozonolysis of structure I produces aldehyde only

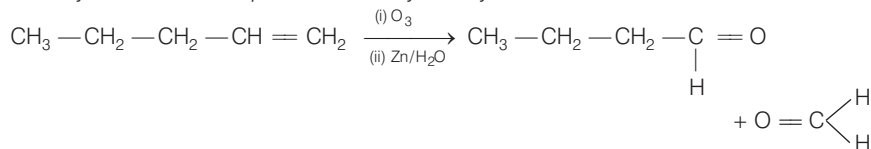

Ozonolysis of structure II produces aldehyde only

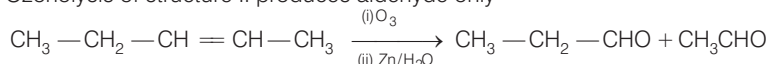

Ozonolysis of structure III produces aldehyde only

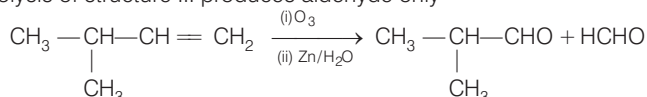

Ozonolysis of structure IV produces both aldehyde and ketone

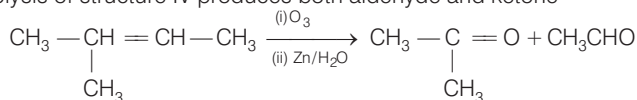

After ozonolysis of each of structures I, II and III produces only aldehydes as both components. But as given in the question one compound doesn't give Fehling test but must

give iodoform test. Hence, compound must be a ketone with  $\text{CH}_3 - \overset{\text{O}}{\parallel}{\text{C}} -$  group. Hence, correct structure is IV.

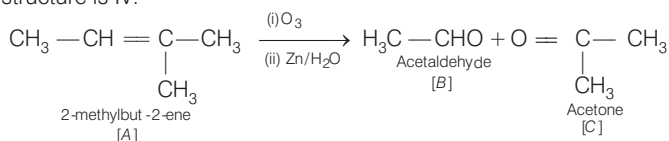

Formation of iodoform from 'B' and 'C' may be explained as follows

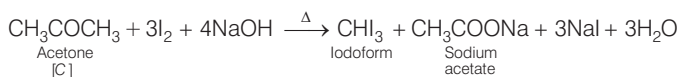
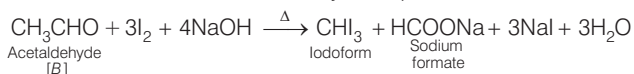

- Q. 48** An aromatic compound 'A' (molecular formula  $\text{C}_8\text{H}_8\text{O}$ ) gives positive 2, 4-DNP test. It gives a yellow precipitate of compound 'B' on treatment with iodine and sodium hydroxide solution. Compound 'A' does not give Tollen's or Fehling's test. On drastic oxidation with potassium permanganate it forms a carboxylic acid 'C' (molecular formula  $\text{C}_7\text{H}_6\text{O}_2$ ), which is also formed along with the yellow compound in the above reaction. Identify A, B and C and write all the reactions involved.

### Thinking Process

This problem is based on conceptual mixing of 2, 4-DNP test, iodoform test and oxidation reactions. Search the key point by using by which this question can be answered easily. Follow the following stepwise approach to solve this question.

- Determine all possible structures of molecule using degree of unsaturation.
- Use the concept of chemical test given by aldehyde and ketone to identify the correct structure.
- After choosing any predicted structure complete the sequence of reaction.

**Ans.** Molecular formula =  $C_8H_8O$

$$\begin{aligned} \text{Degree of unsaturation} &= (C_n + 1) - \frac{H_n}{2} \\ &= (8 + 1) - \frac{8}{2} = 9 - 4 = 5 \end{aligned}$$

Degree of unsaturation  $> 5$  i.e., it may contain benzene ring having degree of unsaturation equal to 4 and one degree of unsaturation must be carbonyl group.

Thus, possible structures are

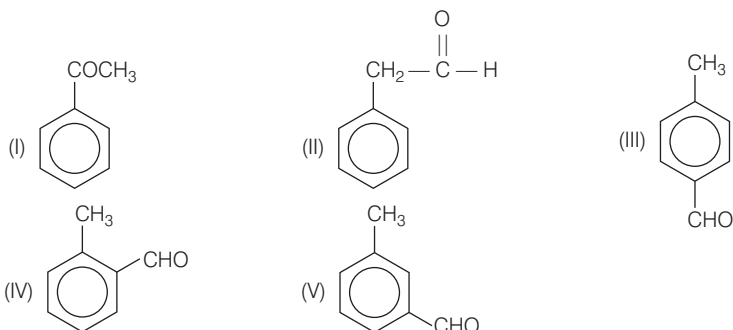

According to question, compound 'A' does not respond to Tollen's or Fehling's test. So, it is a ketone not aldehyde. Therefore, structure I is correct. Complete reaction sequence is as follows

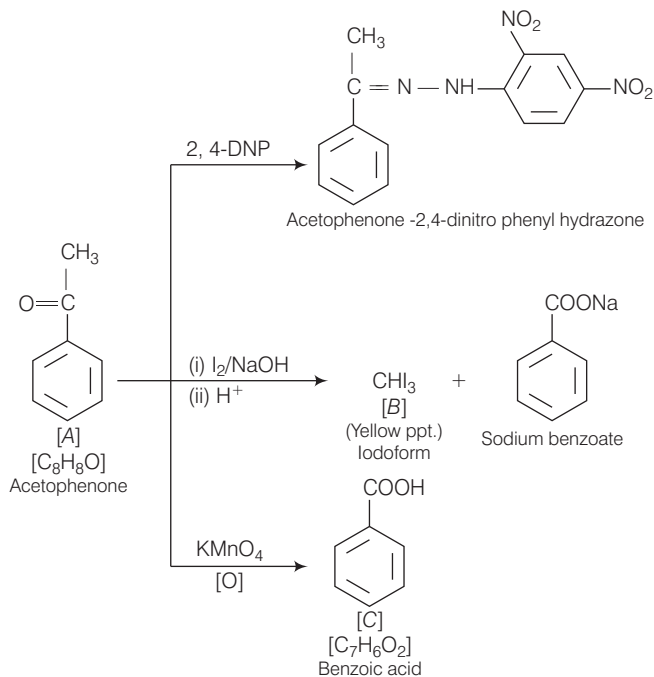

**Q. 49** Write down functional isomers of a carbonyl compound with molecular formula  $C_3H_6O$ . Which isomer will react faster with HCN and why? Explain the mechanism of the reaction also. Will the reaction lead to the completion with the conversion of whole reactant into product at reaction conditions? If a strong acid is added to the reaction mixture what will be the effect on concentration of the product and why?

**Ans.** Functional isomers of  $C_3H_6O$  containing carbonyl group are

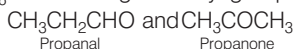

(a) Propanal,  $CH_3CH_2CHO$  will react faster with HCN because there is less steric hindrance and electronic factors, which increases its electrophilicity.

(b) The reaction mechanism is as follow

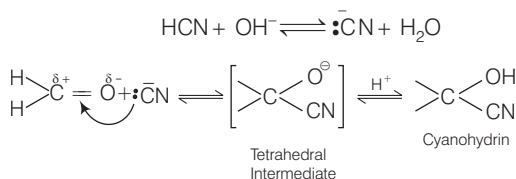

The reaction does not lead to completion because it is a reversible reaction. Equilibrium is established.

(c) If a strong acid is added to the reaction mixture, the reaction is inhibited because production of  $\bar{C}N$  ions is prevented.

**Q. 50** When liquid 'A' is treated with a freshly prepared ammoniacal silver nitrate solution it gives bright silver mirror. The liquid forms a white crystalline solid on treatment with sodium hydrogen sulphite. Liquid 'B' also forms a white crystalline solid with sodium hydrogen sulphite but it does not give test with ammoniacal silver nitrate. Which of the two liquids is aldehyde? Write the chemical equations of these reactions also.

**Ans.** Since the liquid A reduces ammoniacal silver nitrate, (Tollen's reagent), it 'A' is aldehyde.

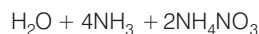
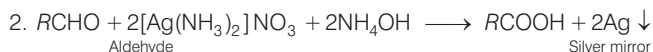
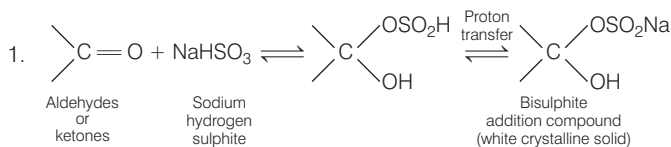

**Note** Aldehyde and ketone both gives white crystallie solid with sodium hydrogen sulphite but this is only aldehyde which gives Tollen's test and Fehling's test.

# 13

## Amines

### Multiple Choice Questions (MCQs)

**Q. 1** Which of the following is a 3° amine?

- (a) 1-methylcyclohexylamine      (b) Triethylamine  
(c) *tert*-butylamine      (d) N-methylaniline

**Ans. (b)** The structure of given amines are as follows

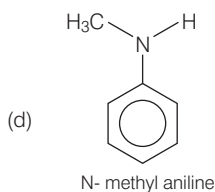
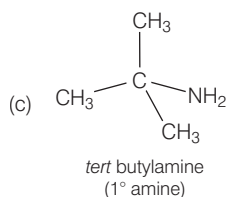
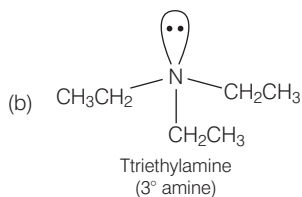
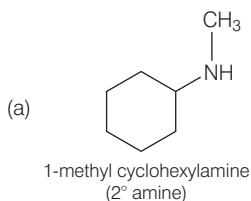

Hence, triethylamine is tertiary amine. The correct choice is (b).

**Q. 2** The correct IUPAC name for  $\text{CH}_2 = \text{CHCH}_2\text{NHCH}_3$  is

- (a) allyl methylamine      (b) 2-amino-4-pentene  
(c) 4-aminopent-1-ene      (d) N-methylprop-2-en-1-amine

**Ans. (d)** IUPAC name of  $\overset{3}{\text{CH}_2} = \overset{2}{\text{CH}}\overset{1}{\text{CH}_2}\text{NHCH}_3$  is N-methylprop-2-en-1-amine

Hence, option (d) is correct.

**Q. 3** Amongst the following, the strongest base in aqueous medium is .....

- (a)  $\text{CH}_3\text{NH}_2$  (b)  $\text{NCCH}_2\text{NH}_2$   
 (c)  $(\text{CH}_3)_2\text{NH}$  (d)  $\text{C}_6\text{H}_5\text{NHCH}_3$

**Thinking Process**

This problem is based on concept of basic strength of various types of amine depending upon inductive effect, resonance and solvation.

**Ans. (c)**

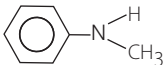
Compound	Factors responsible for basic character are
(a) $\text{CH}_3 - \text{NH}_2$	Inductive effect (+ I)
(b) $\text{NC} - \text{CH}_2 - \text{NH}_2$	Inductive effect (- I)
(c) $(\text{CH}_3)_2\text{NH}$	Inductive effect (+ I) and Solvation
(d) 	- I effect and resonance

Since, + I effect and solvation increases basic character while -I effect and resonance decreases basic character. Hence, correct choice is (c).

**Q. 4** Which of the following is the weakest Bronsted base?

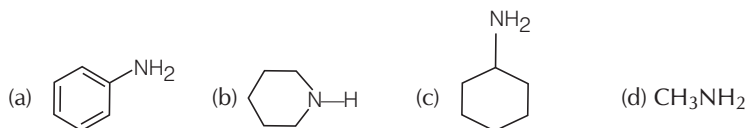

**Ans. (a)** Aniline is weakest Bronsted base among the given four compounds due to resonance present in case of aniline.

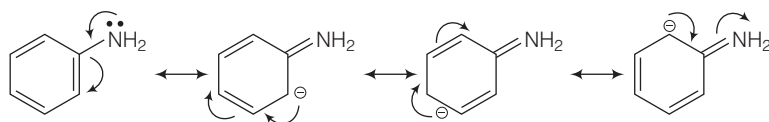

Resonating structure of aniline

Hence, lone pair of nitrogen are less available for donation to the acid.

**Q. 5** Benzylamine may be alkylated as shown in the following equation?

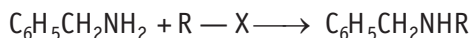

Which of the following alkyl halides is best suited for this reaction through  $\text{S}_{\text{N}}1$  mechanism?

- (a)  $\text{CH}_3\text{Br}$  (b)  $\text{C}_6\text{H}_5\text{Br}$   
 (c)  $\text{C}_6\text{H}_5\text{CH}_2\text{Br}$  (d)  $\text{C}_2\text{H}_5\text{Br}$





**Ans. (d)** Source of nitrogen in Gabriel phthalimide synthesis is potassium phthalimide.

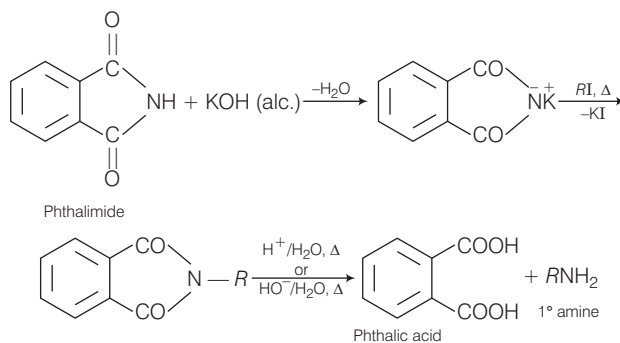

**Q. 9** Amongst the given set of reactants, the most appropriate for preparing 2° amine is .....

- (a)  $2^\circ R - Br + NH_3$   
 (b)  $2^\circ R - Br + NaCN$  followed by  $H_2 / Pt$   
 (c)  $1^\circ R - NH_2 + RCHO$  followed by  $H_2 / Pt$   
 (d)  $1^\circ R - Br$  (2 mol) + potassium phthalimide followed by  $H_3O^+ / \text{heat}$

**Ans. (c)**

Chemical transformation can be shown as

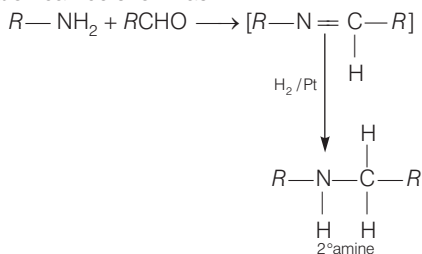

While other given set of reactants give primary amine only.

**Q. 10** The best reagent for converting 2-phenylpropanamide into 2-phenylpropanamine is .....

- (a) excess  $H_2$   
 (b)  $Br_2$  in aqueous  $NaOH$   
 (c) iodine in the presence of red phosphorus  
 (d)  $LiAlH_4$  in ether

**Ans. (d)** The best reagent for converting 2-phenylpropanamide into 2-phenylpropanamine is  $\text{LiAlH}_4$  in ether. Reaction is as given below

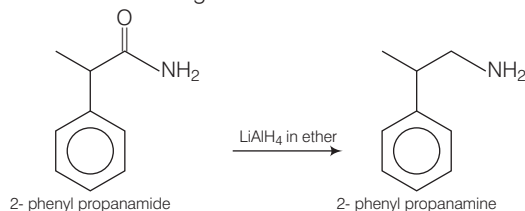

**Q. 11** The best reagent for converting, 2-phenylpropanamide into 1-phenylethanamine is .....

- (a) excess  $\text{H}_2$  / Pt (b)  $\text{NaOH}$  /  $\text{Br}_2$   
 (c)  $\text{NaBH}_4$  / methanol (d)  $\text{LiAlH}_4$  / ether

**Ans. (b)** The best reagent for converting 2-phenylpropanamide into 1-phenylethanamine is by  $\text{NaOH} / \text{Br}_2$  and chemical transformation can be done as

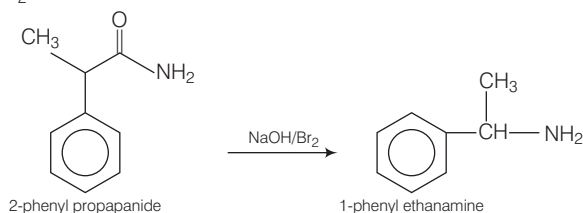

This occurs due to intramolecular migration of alkyl group. It is an example of Hofmann bromamide reaction.

**Q. 12** Hofmann bromamide degradation reaction is shown by .....

- (a)  $\text{ArNH}_2$  (b)  $\text{ArCONH}_2$   
 (c)  $\text{ArNO}_2$  (d)  $\text{ArCH}_2\text{NH}_2$

**Ans. (b)** Hofmann bromamide degradation is shown by  $\text{Ar}-\overset{\text{O}}{\parallel}{\text{C}}-\text{NH}_2$  by which amide is converted into amine *via* undergoing intramolecular migration of phenyl group.

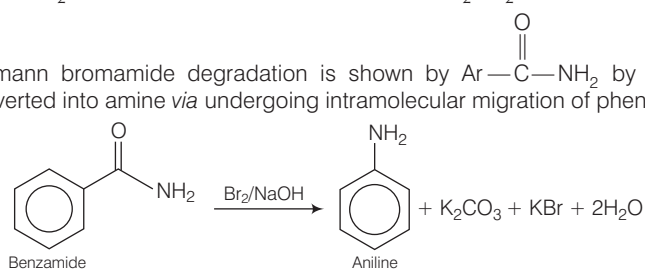

**Q. 13** The correct increasing order of basic strength for the following compounds is .....

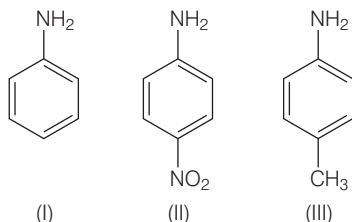

- (a) II < III < I      (b) III < I < II      (c) III < II < I      (d) II < I < III

**Ans. (d)** The correct increasing order of basic strength is as follows

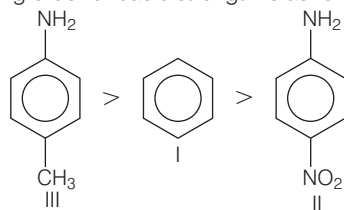

Greater the electron density towards ring, greater will be its basic strength.

Electron withdrawing group decreases basic strength while electron donating group increases basic strength.

**Q. 14** Methylamine reacts with  $\text{HNO}_2$  to form .....

- (a)  $\text{CH}_3 - \text{O} - \text{N} = \text{O}$       (b)  $\text{CH}_3 - \text{O} - \text{CH}_3$   
(c)  $\text{CH}_3\text{OH}$       (d)  $\text{CH}_3\text{CHO}$

**Ans. (c)** Methylamine reacts with  $\text{HNO}_2$  (nitrous acid) to form methanol.

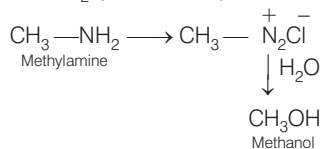

**Q. 15** The gas evolved when methylamine reacts with nitrous acid is .....

- (a)  $\text{NH}_3$       (b)  $\text{N}_2$   
(c)  $\text{H}_2$       (d)  $\text{C}_2\text{H}_6$

**Ans. (b)** Chemical reaction takes place during reaction of methylamine with nitrous acid is as follows

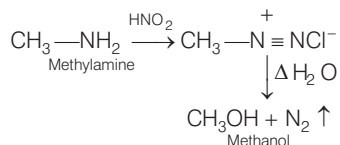

**Q. 16** In the nitration of benzene using a mixture of conc.  $\text{H}_2\text{SO}_4$  and conc.  $\text{HNO}_3$ , the species which initiates the reaction is .....

- (a)  $\text{NO}_2$  (b)  $\text{NO}^+$   
(c)  $\text{NO}_2^+$  (d)  $\text{NO}_2^-$

**Ans. (c)** Nitration of benzene using a mixture of conc.  $\text{H}_2\text{SO}_4$  and conc.  $\text{HNO}_3$  proceeds as

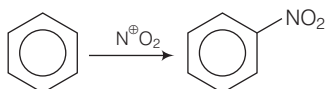
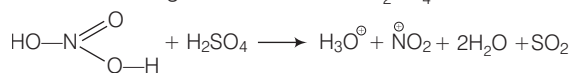

This reaction is known as electrophilic substitution reaction.

**Q. 17** Reduction of aromatic nitro compounds using Fe and HCl gives .....

- (a) aromatic oxime (b) aromatic hydrocarbon  
(c) aromatic primary amine (d) aromatic amide

**Ans. (c)** Aromatic nitro compound on reaction with Fe and HCl gives aromatic primary amine as shown below

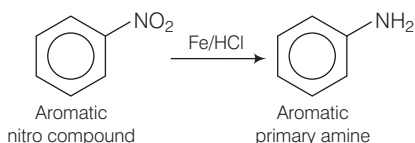

**Q. 18** The most reactive amine towards dilute hydrochloric acid is .....

- (a)  $\text{CH}_3-\text{NH}_2$  (b)
- (c) (d)

**Ans. (b)** Greater will be the strength of base, greater will be its reactivity towards dilute HCl. Hence,  $(\text{CH}_3)_2\text{NH}$  has highest basic strength as it has highest reactivity.

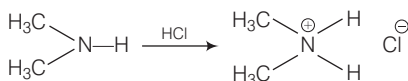

**Q. 19** Acid anhydrides on reaction with primary amines give .....

- (a) amide (b) imide  
(c) secondary amine (d) imine

**Ans. (a)** Acid anhydride on reaction with primary amine produces amide as

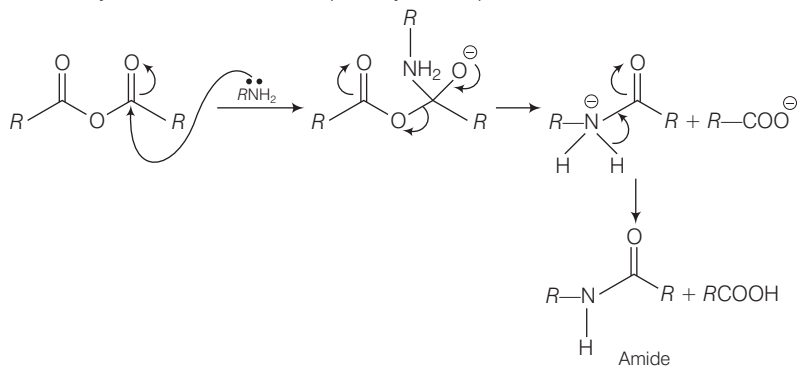

**Q. 20** The reaction  $ArN_2^+ Cl^- \xrightarrow{Cu/HCl} ArCl + N_2 + CuCl$  is named as .....

- (a) Sandmeyer reaction                      (b) Gattermann reaction  
(c) Claisen reaction                        (d) Carbylamine reaction

**Ans. (b)**

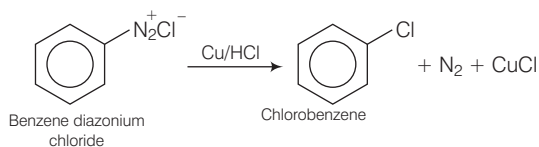

This reaction is called Gattermann reaction. In this reaction, Cl, Br and CN can be introduced into the benzene ring by simply treating diazonium salts with HCl, HBr, KCN, respectively in presence of copper powder instead of using Cu (I) salts.

**Q. 21** Best method for preparing primary amines from alkyl halides without changing the number of carbon atoms in the chain is

- (a) Hofmann bromamide reaction            (b) Gabriel phthalimide synthesis  
(c) Sandmeyer reaction                      (d) reaction with  $NH_3$

**Ans. (b)** Best method of preparing primary amines from alkyl halides without changing the number of carbon atoms in the chain is Gabriel phthalimide synthesis

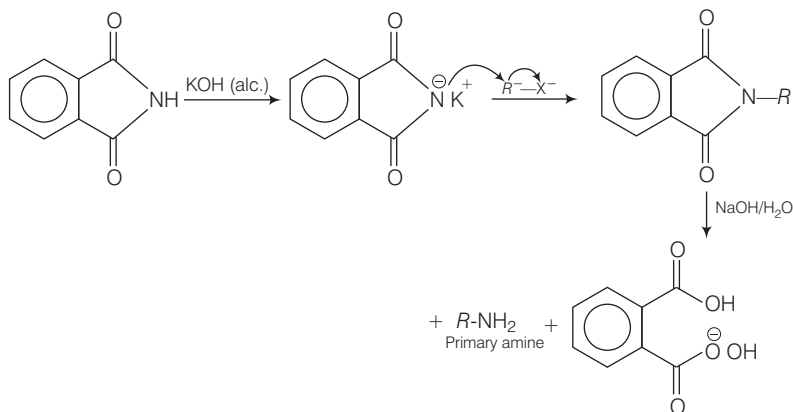

**Q. 22** Which of the following compound will not undergo azo coupling reaction with benzene diazonium chloride?

- (a) Aniline                      (b) Phenol                      (c) Anisole                      (d) Nitrobenzene

**Ans. (d)** Nitrobenzene will not undergo azo coupling reaction with benzene diazonium chloride while other three undergo azo coupling reaction very easily. Diazonium cation is a weak  $E^+$  and hence reacts with electron rich compounds containing electron donating group *i.e.*,  $-\text{OH}$ ,  $-\text{NH}_2$  and  $-\text{OCH}_3$  groups and not with compounds containing electron withdrawing group, *i.e.*,  $\text{NO}_2$  etc.

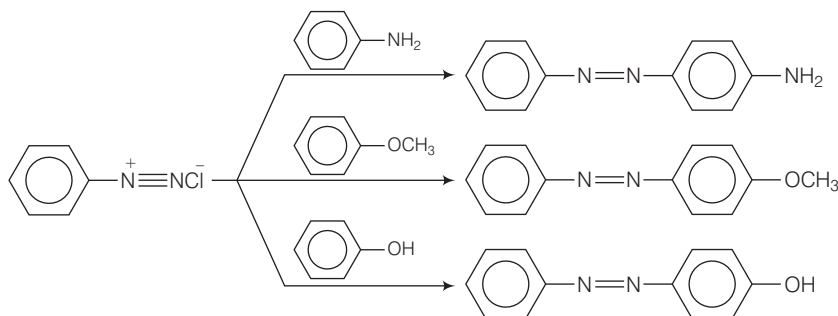

**Q. 23** Which of the following compounds is the weakest Bronsted base?

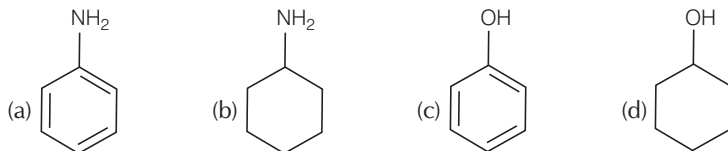

**Ans. (c)** Phenol is weakest Bronsted base as phenol after losing  $\text{H}^+$  produces least stable conjugate acid among the compounds.

Oxygen has more electronegative than N. So,  $\text{O}-\text{H}$  bond is more polar and it has highest value of acidic character. Since, phenol is more acidic than alcohol, therefore, phenol has the least tendency to accept a proton and hence it is weak Bronsted base. Hence, phenol is least basic among given four choices.

**Q. 24** Among the following amines, the strongest Bronsted base is .....



**Ans. (d)** Aniline is a weaker base than  $\text{NH}_3$  due to delocalization of lone pair of electrons of the N-atom over the benzene ring. Pyrrole is not more basic because the lone pair of electrons on the N-atom is donated towards aromatic sextet formation.

Therefore, pyrrolidine is strongest base as lone pair of nitrogen does not involve in resonance and also due to presence of two alkyl ring residue, basic strength becomes high among given four compounds.





Heating alkyl halide with potassium salt of phthalimide followed by hydrolysis produces primary amine. This process is known as Gabriel phthalimide reaction. The number of carbon atoms in the chain of amines of product is same as reactant.

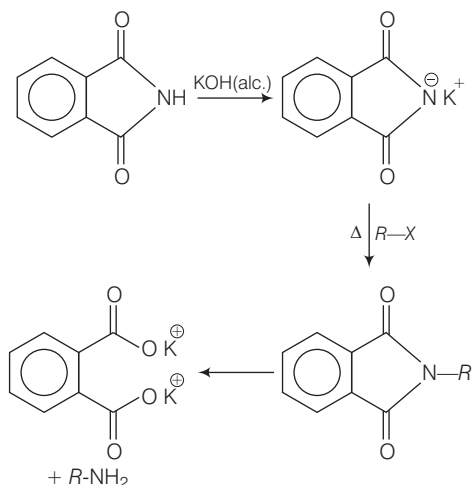

## Multiple Choice Questions (More Than One Options)

**Q. 28** Which of the following cannot be prepared by Sandmeyer's reaction?

- (a) Chlorobenzene                      (b) Bromobenzene  
(c) Iodobenzene                        (d) Fluorobenzene

**Ans. (c, d)**

Sandmeyer's reaction is used for preparation of chlorobenzene and bromobenzene.

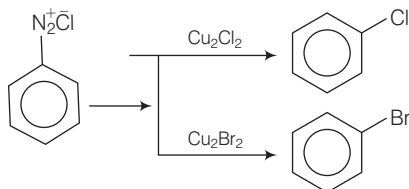

Iodobenzene and fluorobenzene can be prepared by direct reaction of diazonium salt with KI and HBF<sub>4</sub>/Δ.

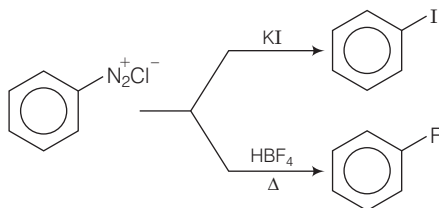

**Q. 29** Reduction of nitrobenzene by which of the following reagent gives aniline?

- (a) Sn/HCl                      (b) Fe/HCl                      (c)  $H_2 - Pd$                       (d) Sn /  $NH_4OH$

**Ans. (a, b, c)**

Reduction of nitrobenzene by Sn/HCl, Fe/HCl and  $H_2 - Pd$  gives aniline as follows

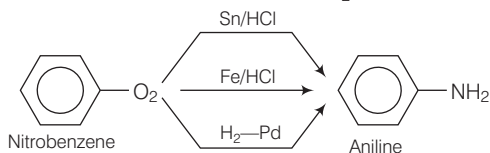

**Q. 30** Which of the following species are involved in the carbylamine test?

- (a)  $R-NC$                       (b)  $CHCl_3$                       (c)  $COCl_2$                       (d)  $NaNO_2 + HCl$

**Ans. (a, b)**

**Carbylamine reaction** Amine on reaction with a mixture of  $CHCl_3$  and  $KOH$  produces alkyl isocyanate.  $R-NH_2 + CHCl_3 + 3KOH \longrightarrow RNC + 3KCl + 3H_2O$

Only  $RNC$  and  $CHCl_3$  are involved in carbylamine reaction. Hence, (a) and (b) are correct.

**Q. 31** The reagents that can be used to convert benzenediazonium chloride to benzene are .....

- (a)  $SnCl_2 / HCl$                       (b)  $CH_3CH_2OH$                       (c)  $H_3PO_2$                       (d)  $LiAlH_4$

**Ans. (b, c)**

Benzene diazonium chloride can be converted into benzene using protic acid as follows

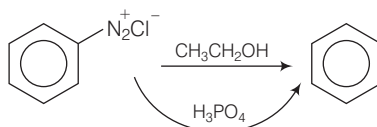

**Q. 32** The product of the following reaction is .....

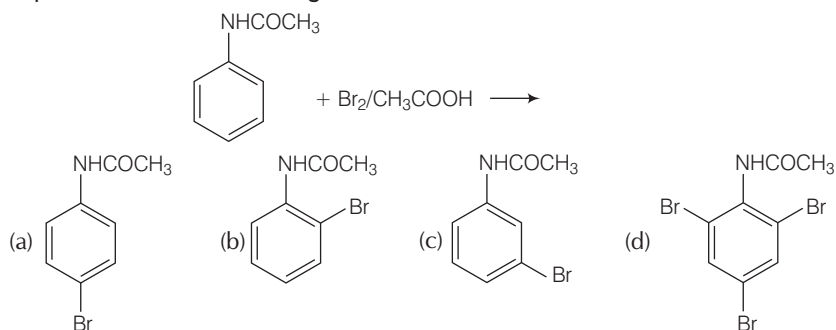





**Q. 37** Which of the following reactions belong to electrophilic aromatic substitution?

- (a) Bromination of acetanilide
- (b) Coupling reaction of aryldiazonium salts
- (c) Diazotisation of aniline
- (d) Acylation of aniline

**Ans. (a, b)**

Bromination of acetanilide and coupling reaction of aryldiazonium salts is an example of electrophilic aromatic substitution reaction.

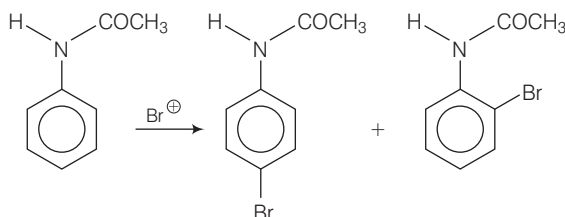

Coupling reaction of aryldiazonium salts

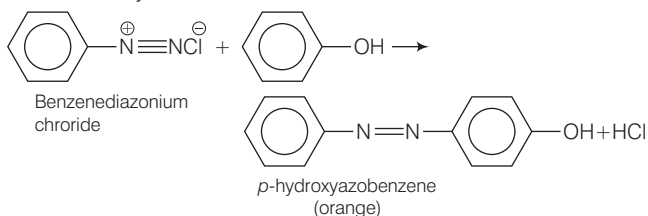

## Short Answer Type Questions

**Q. 38** What is the role of  $\text{HNO}_3$  in the nitrating mixture used for nitration of benzene?

**Ans.**  $\text{HNO}_3$  acts as a base in the nitrating mixture and provide the electrophile,  $\text{NO}_2^+$  on reaction with  $\text{H}_2\text{SO}_4$  as follows

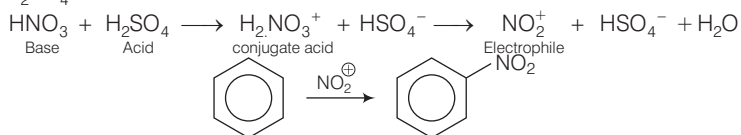

**Q. 39** Why is  $\text{NH}_2$  group of aniline acetylated before carrying out nitration?

**Ans.** In order to check the activation of benzene ring by amino group, first it is acetylated with acetic anhydride or acetyl chloride in presence of pyridine to form acetanilide which can be further nitrated easily by nitrating mixture.

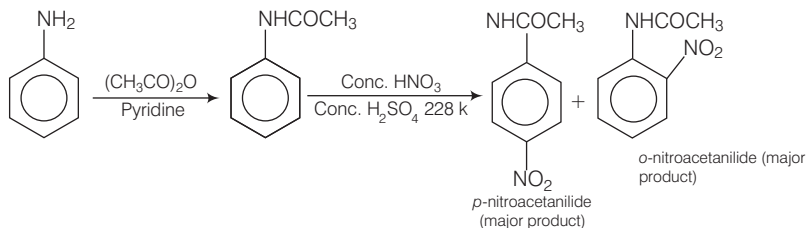

**Q. 40** What is the product when  $\text{C}_6\text{H}_5\text{CH}_2\text{NH}_2$  reacts with  $\text{HNO}_2$ ?

**Ans.**  $\text{C}_6\text{H}_5\text{CH}_2\text{NH}_2$  on reaction with  $\text{HNO}_2$  produces  $\text{C}_6\text{H}_5\text{CH}_2\text{N}_2^+\text{Cl}^-$  as follows

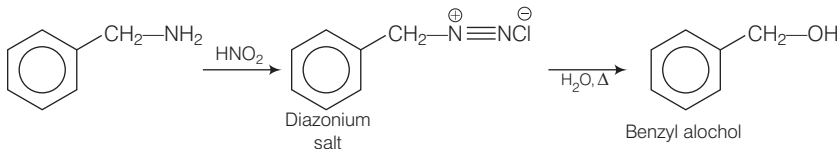

**Q. 41** What is the best reagent to convert nitrile to primary amine?

**Ans.** Best reagent to convert nitrile to aniline is sodium/alcohol or  $\text{LiAlH}_4$ .

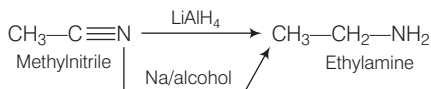

**Q. 42** Give the structure of 'A' in the following reaction.

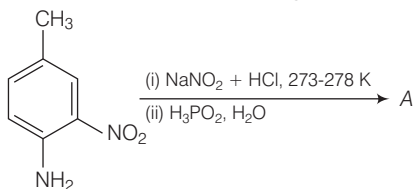

### 💡 Thinking Process

This problem is based on the concept of preparation of diazonium salt and its chemical properties.

**Ans.** Complete conversion can be shown as

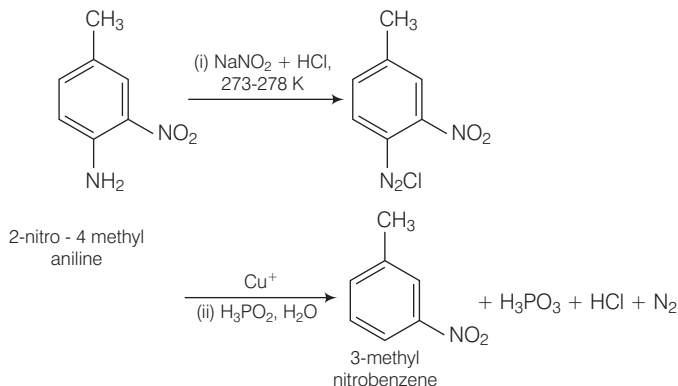

**Q. 43** What is Hinsberg reagent?

**Ans.** Benzene sulphonyl chloride ( $\text{C}_6\text{H}_5\text{SO}_2\text{Cl}$ ) is known as Hinsberg reagent. It is used to distinguish between primary, secondary and tertiary amine.

**Q. 44** Why is benzene diazonium chloride not stored and is used immediately after its preparation?

**Ans.** Benzene diazonium chloride are highly unstable and stable for a very short time span in solution at low temperature. Due to its instability, it is used immediately after its preparation.

**Q. 45** Why does acylation of  $-\text{NH}_2$  group of aniline reduces its activating effect?

**Ans.** Acylation of  $-\text{NH}_2$  group of aniline reduces its activity due to resonance of lone pair of nitrogen towards the carbonyl group hence  $o-$ ,  $p^-$  directive influence of amino group get disturbed.

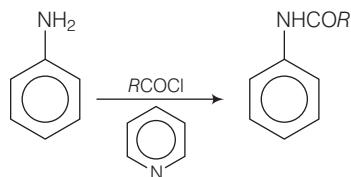

The resonating structure are

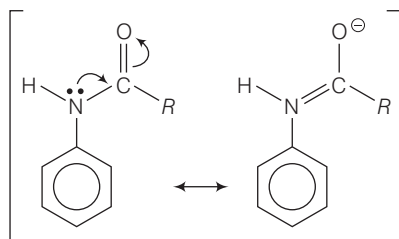

**Q. 46** Explain why  $\text{MeNH}_2$  is stronger base than  $\text{MeOH}$ ?

**Ans.** Basicity of  $\text{MeNH}_2$  and  $\text{MeOH}$  can be explained on the basis of electronegativity of N and O atom.  $\text{MeNH}_2$  is stronger base than  $\text{MeOH}$  because of low electronegativity value of N, it is easy for nitrogen to lose its lone pair readily than compared to  $\text{MeOH}$ .

**Q. 47** What is the role of pyridine in the acylation reaction of amines?

**Ans.** Pyridine being a base, is used to remove the side product *i.e.*,  $\text{HCl}$  from reaction mixture.

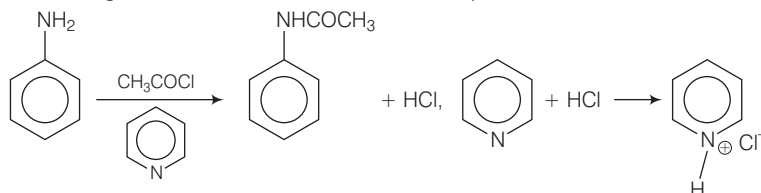

**Q. 48** Under what reaction condition (acidic, basic) the coupling reaction of aryl diazonium chloride with aniline is carried out?

**Ans.** In strongly basic conditions, benzenediazonium chloride is converted into diazohydroxide and diazoate as both of which are not electrophilic and do not couple with aniline.

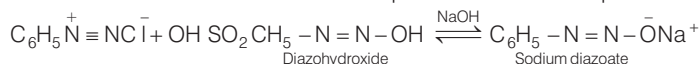

Similarly, in highly acidic conditions, aniline gets converted into anilinium ion. From this, result aniline is no longer nucleophilic and hence will not couple with diazonium chloride. Hence, the reaction is carried out under mild conditions, *i.e.*,  $\text{pH} \sim 4-5$

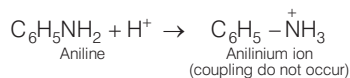

**Q. 49** Predict the product of reaction of aniline with bromine in non-polar solvent such as  $\text{CS}_2$ .

**Ans.** Aniline on reaction with  $\text{Br}_2$  in non-polar solvent  $\text{CS}_2$  produces 2, 4, 6 tribromo aniline.

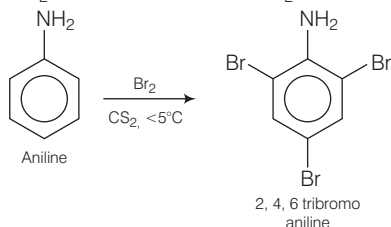

Aniline has high reactivity towards bromine as it gives the triply substituted product.

**Q. 50** Arrange the following compounds in increasing order of dipole moment.



**Ans.** Dipole moment of amine, alcohol and hydrocarbon can be explained on the basis of bond polarity of  $\text{C}-\text{H}$ ,  $\text{N}-\text{H}$  and  $\text{O}-\text{H}$  bond. As the bond polarity increase, dipole moment increases  $\text{CH}_3\text{CH}_2\text{CH}_3 < \text{CH}_3\text{CH}_2\text{NH}_2 < \text{CH}_3\text{CH}_2\text{OH}$



**Q. 51** What is the structure and IUPAC name of the compound, allyl amine?

**Ans.** Structural formula of allyl amine is as follows

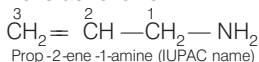

**Q. 52** Write down the IUPAC name of

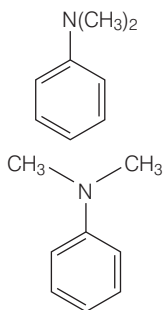

**Ans.**

N, N-dimethyl benzenamine

During naming of N-substituted amine, substituted group present at N are added as suffix on N-alkyl in IUPAC nomenclature.

**Q. 53** A compound Z with molecular formula  $\text{C}_3\text{H}_9\text{N}$  reacts with  $\text{C}_6\text{H}_5\text{SO}_2\text{Cl}$  to give a solid, insoluble in alkali. Identify Z.

**Thinking Process**

*This process is based on concept of Hinsberg test. Only amine containing replaceable H gives Hinsberg test.*

**Ans.**  $\text{Z}(\text{C}_3\text{H}_9\text{N})$  is an aliphatic amine. On reaction with  $\text{C}_6\text{H}_5\text{SO}_2\text{Cl}$  (Hinsberg's reagent), it gives a product insoluble in alkali. It means that the product does not have a replaceable H-atom attached to the N-atom. So, compound Z is a secondary amine (ethyl methyl amine).

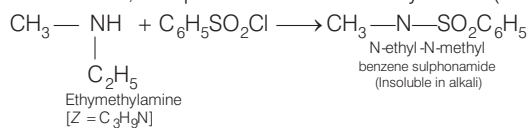

**Q. 54** A primary amine,  $\text{RNH}_2$  can be reacted with  $\text{CH}_3\text{—X}$  to get secondary amine,  $\text{R—NHCH}_3$  but the only disadvantage is that  $3^\circ$  amine and quaternary ammonium salts are also obtained as side products. Can you suggest a method where  $\text{RNH}_2$  forms only  $2^\circ$  amine?

**Ans.**



Primary amines show carbylamine reaction in which two H-atoms attached to N-atoms of  $\text{NH}_2$  are replaced by one C-atom. On catalytic reduction, isocyanide (formed) produces secondary amine and not tertiary or quaternary salts.

**Q. 55** Complete the following reaction.

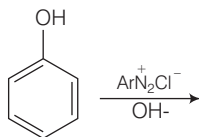

**Ans.** The reaction exhibits azo-coupling reaction of phenols. Benzene diazonium chloride reacts with phenol in such a manner that the *para* position of phenol is coupled with diazonium salt to form *p*-hydroxy azobenzene.

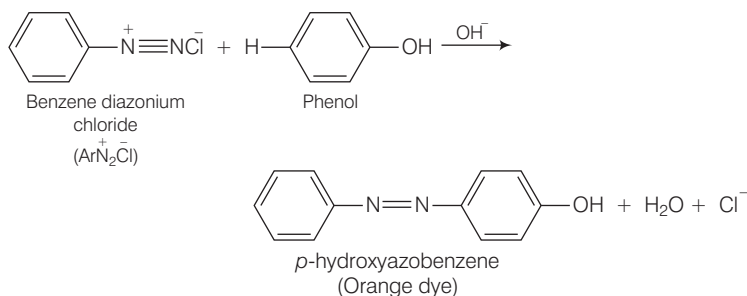

**Q. 56** Why is aniline soluble in aqueous HCl?

**Ans.** Aniline is soluble in aqueous HCl due to formation of ionic anilinium chloride.

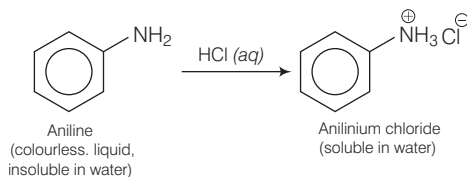

**Q. 57** Suggest a route by which the following conversion can be accomplished.

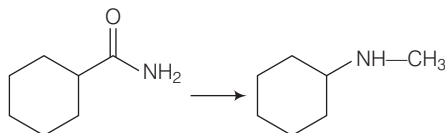

**Ans.** Complete conversion can be performed as

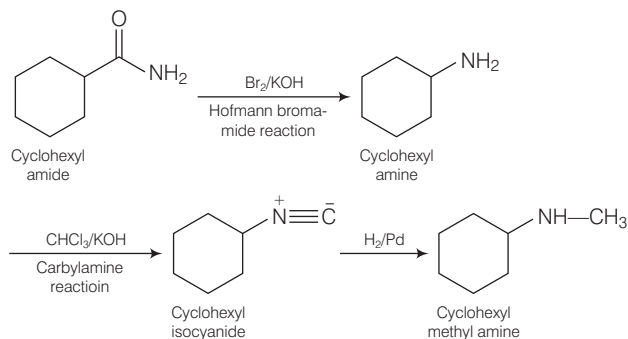

**Q. 58** Identify A and B in the following reaction.

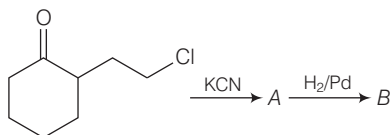

**Ans.** Complete conversion can be performed as

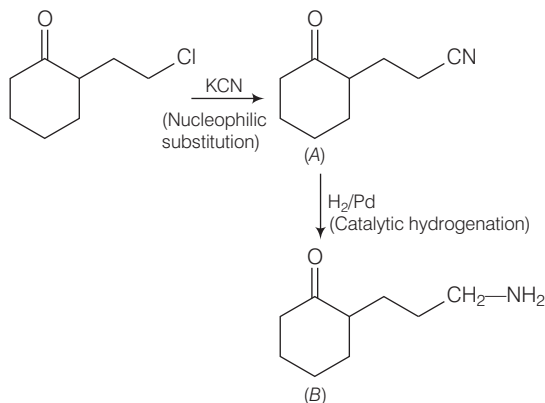

Hence,

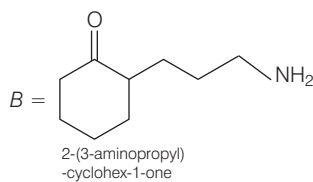
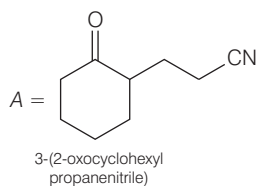

**Q. 59** How will you carry out the following conversions?

(i) Toluene  $\longrightarrow$  *p*-toluidine

(ii) *p*-toluidine diazonium chloride  $\longrightarrow$  *p*-toluic acid

**Ans.** (i) Conversion of toluene to *p*-toluidine can be done as

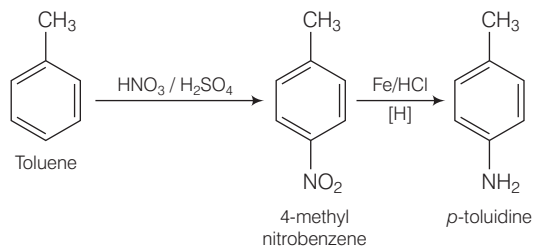

(ii) Conversion of *p*-toluidine diazonium chloride to *p*-toluic acid can be done as

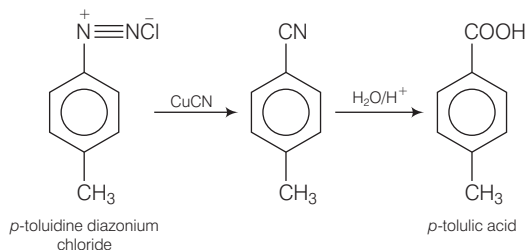

**Q. 60** Write following conversions

(i) Nitrobenzene  $\longrightarrow$  Acetanilide

(ii) Acetanilide  $\longrightarrow$  *p*-nitroaniline

**Ans.** (i) Nitrobenzene can be converted into acetanilide as follows

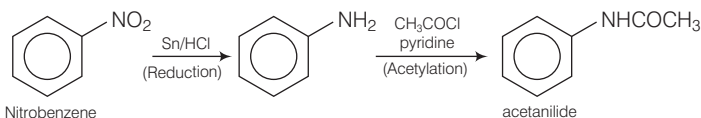

(ii) Acetanilide can be converted into *p*-nitroaniline as follows

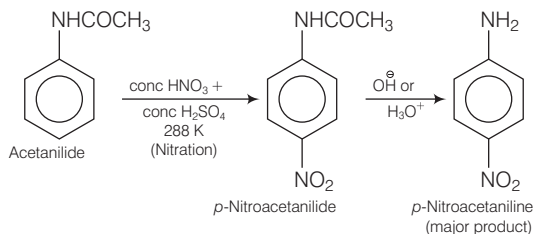

**Q. 61** A solution contains 1 g mol. each of *p*-toluene diazonium chloride and *p*-nitrophenyl diazonium chloride. To this 1 g mol. of alkaline solution of phenol is added. Predict the major product. Explain your answer.

**Thinking Process**

*This problem is based upon conceptual mixing of electrophilicity of ring system and diazo-coupling reaction.*

**Ans.** The above stated reaction is an example of electrophilic aromatic substitution. In alkaline medium, phenol generates phenoxide ion which is more electron rich than phenol and more reactive for electrophilic attack.

The electrophile in this reaction is aryldiazonium cation. As we know, stronger the electrophile faster is the reaction. *p*-nitrophenyldiazonium cation is a stronger electrophile than *p*-toluene diazonium cation.

So, nitrophenyl diazonium chloride couples preferentially with phenol.

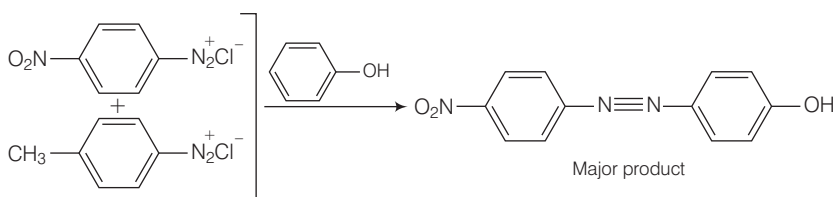

**Q. 62** How will you bring out the following conversion?

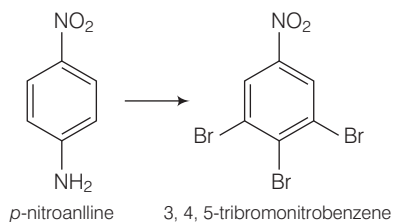

### 💡 Thinking Process

This problem includes conceptual mixing of bromination, nitration and Sandmeyer's reaction. Follow the steps to approach towards given product.

Bromination of *p*-nitroaniline followed by diazotisation and Sandmeyer's reaction

**Ans.** Complete conversion of above reaction can be shown as

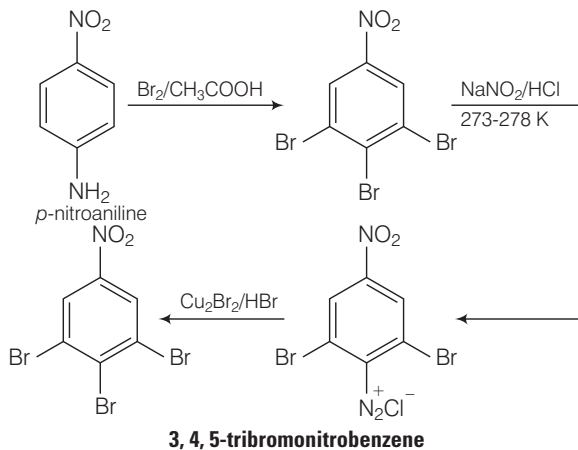

**Q. 63** How will you carry out the following conversion?

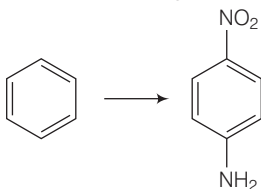

**Ans.** Conversion of benzene to *p*-nitroaniline can be done as

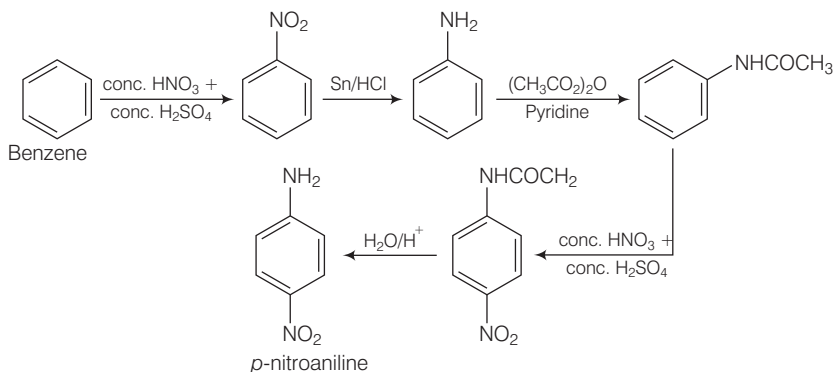

**Q. 64** How will you carry out the following conversion?

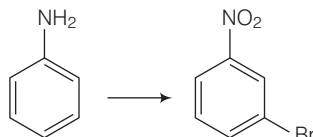

**Ans.** Conversion of aniline to *m*-bromo nitrobenzene can be completed as

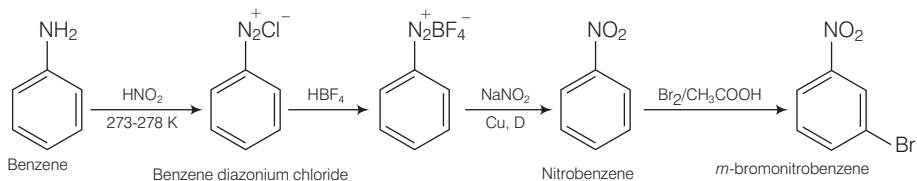

**Q. 65** How will you carry out the following conversions?

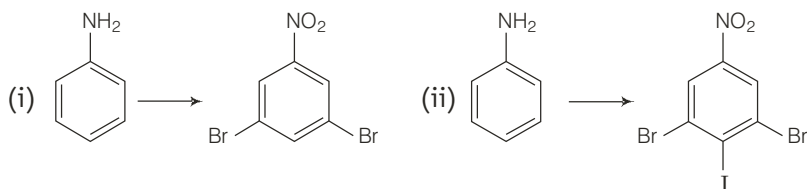

**Ans.** (i) Conversion of aniline to 3, 5-dibromonitrobenzene can be completed as

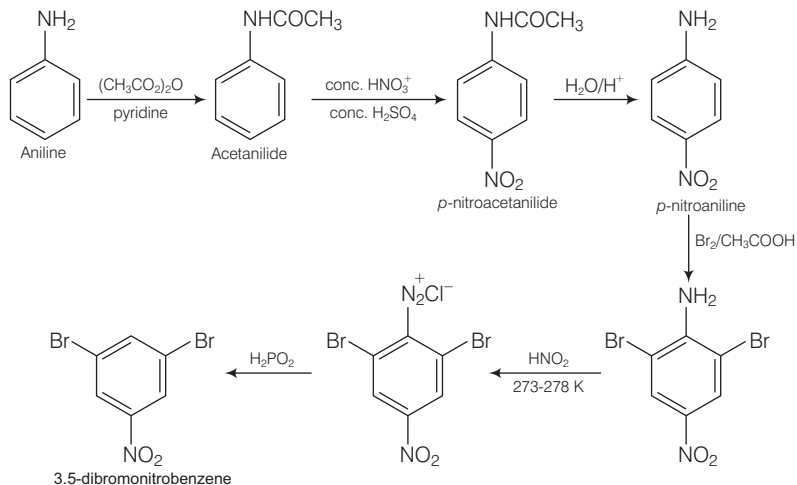

(ii) Conversion (A) given below is same as in part (i) given above after that reaction (B) can be carried out.

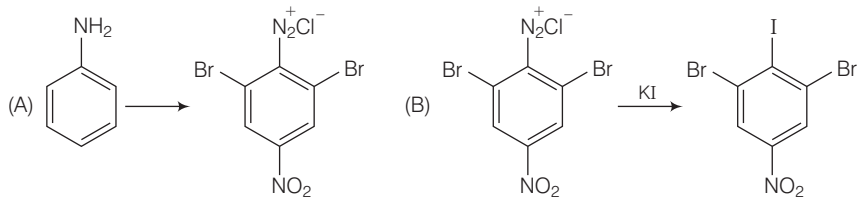

## Matching The Columns

**Q. 66** Match the reactions given in Column I with the statements given in Column II.

Column I	Column II
A. Ammonolysis	1. Amine with lesser number of carbon atoms
B. Gabriel phthalimide synthesis	2. Detection test for primary amines.
C. Hofmann bromamide reaction	3. Reaction of phthalimide with KOH and $R-X$
D. Carbylamine reaction	4. Reaction of alkylhalides with $\text{NH}_3$

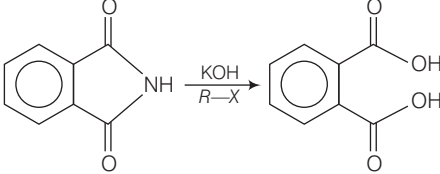

Ans. A. → (4)    B. → (3)    C. → (1)    D. → (2)

Reaction	Statements
A. Ammonolysis	Reaction of alkylhalide with $\text{NH}_3$ $R-X \longrightarrow \text{RNH}_2 + \text{HCl}$
B. Gabriel phthalimide synthesis	Reaction of phthalimide with $\text{KOH}$ and $R-X$ . 
C. Hofmann bromamide reaction	Amine with lesser number of carbon atoms. $\text{RCONH}_2 \xrightarrow{\text{NaOX}} \text{RNH}_2$
D. Carbylamine reaction	Detection test of primary amines.

Q. 67 Match the compounds given in Column I with the items given in Column II.

Column I	Column II
A. Benzene sulphonyl chloride	1. Zwitter ion
B. Sulphanilic acid	2. Hinsberg reagent
C. Alkyl diazonium salts	3. Dyes
D. Aryl diazonium salts	4. Conversion to alcohols

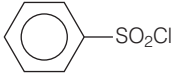
Ans. A. → (2)    B. → (1)    C. → (4)    D. → (3)

Compounds	Items
A. Benzene sulphonyl chloride	Hinsberg reagent 
B. Sulphanilic acid	Zwitter ion (dipolar ion) 
C. Alkyl diazonium salts	Conversion to alcohols $\text{R}-\text{N}_2^+ \text{X}^- \xrightarrow{\text{H}_2\text{O}} \text{ROH}$
D. Aryl diazonium salts	Dyes



## Assertion and Reason

*In the following questions a statement of Assertion (A) followed by a statement of Reason (R) is given. Choose the correct answer out of the following choices.*

- (a) Both assertion and reason are wrong.
- (b) Both assertion and reason are correct statements but reason is not correct explanation of assertion.
- (c) Assertion is correct statement but reason is wrong statement.
- (d) Both assertion and reason are correct statements and reason is correct explanation of assertion.
- (e) Assertion is wrong statement but reason is correct statement.

**Q. 68 Assertion (A)** Acylation of amines gives a monosubstituted product whereas alkylation of amines gives polysubstituted product.

**Reason (R)** Acyl group sterically hinders the approach of further acyl groups.

**Ans. (c)** Assertion is correct statement but reason is wrong statement.

Acylation of amine gives a monosubstituted product whereas alkylation of amine gives polysubstituted product because acylation in amine takes place at N-atom and alkylation takes place at *o* and *p* position.

**Q. 69 Assertion (A)** Hofmann's bromamide reaction is given by primary amines.

**Reason (R)** Primary amines are more basic than secondary amines.

**Ans. (a)** Both assertion and reason are wrong.

**Correct Assertion** Hofmann's bromamide reaction is given by amide.

**Correct Reason** Amide on reaction with NaOX produces amine having one carbon less than amide.

**Q. 70 Assertion (A)** N-ethylbenzene sulphonamide is soluble in alkali.

**Reason (R)** Hydrogen attached to nitrogen in sulphonamide is strongly acidic.

**Ans. (d)** Both assertion and reason are correct and reason is the correct explanation of assertion.

N-ethylbenzene is soluble in alkali because hydrogen attached to nitrogen in sulphonamide is strongly acidic and forms a salt during reaction between these two.

**Q. 71 Assertion (A)** N, N-diethylbenzene sulphonamide is insoluble in alkali.

**Reason (R)** Sulphonyl group attached to nitrogen atom is strong electron withdrawing group.

**Ans. (d)** Both assertion and reason are correct and reason is not the correct explanation of assertion.

N, N-diethylbenzene sulphonamide is insoluble in alkali due to absence of acidic H attached to nitrogen.

**Q. 72 Assertion (A)** Only a small amount of HCl is required in the reduction of nitro compounds with iron scrap and HCl in the presence of steam.

**Reason (R)**  $\text{FeCl}_2$  formed gets hydrolysed to release HCl during the reaction.

**Ans. (d)** Assertion and reason both are correct and reason is the correct explanation of assertion.

Only small amount of HCl is required in the reduction of nitro compounds with iron scrap and HCl in the presence of steam because  $\text{FeCl}_2$  formed gets hydrolysed to release HCl during the reaction.

**Q. 73 Assertion (A)** Aromatic  $1^\circ$  amines can be prepared by Gabriel phthalimide synthesis.

**Reason (R)** Aryl halides undergo nucleophilic substitution with anion formed by phthalimide.

**Ans. (a)** Both assertion and reason are wrong. Aryl  $1^\circ$  amine can't be prepared by Gabriel phthalimide reaction because aryl halide don't undergo nucleophilic substitution with anion formed by phthalimide.

**Q. 74 Assertion (A)** Acetanilide is less basic aniline.

**Reason (R)** Acetylation of aniline results in decrease of electron density on nitrogen.

**Ans. (d)** Assertion and reason both are correct and reason is the correct explanation of assertion.

Acetanilide is less basic than aniline because acetylation of aniline results in decrease of electron density on nitrogen.

## Long Answer Type Questions

**Q. 75** A hydrocarbon 'A' ( $\text{C}_4\text{H}_8$ ) on reaction with HCl gives a compound 'B' ( $\text{C}_4\text{H}_9\text{Cl}$ ), which on reaction with 1 mol of  $\text{NH}_3$  gives compound 'C' ( $\text{C}_4\text{H}_{11}\text{N}$ ). On reacting with  $\text{NaNO}_2$  and HCl followed by treatment with water, compound 'C' yields an optically active alcohol, 'D'. Ozonolysis of 'A' gives 2 mols of acetaldehyde. Identify compounds 'A' to 'D'. Explain the reactions involved.

### Thinking Process

*This problem includes conceptual mixing of ozonolysis, optical activity, ammonolysis and diazotisation. Follow the steps to solve the problem*

*Analyse the overall reaction once then sequentially predict a molecule for each A,B,C and D on the basis of information provided in the question.*

*Fit every molecule in a flow chart made by using information provided in the question and reach to the correct compounds.*

**Ans.** (i) Addition of HCl to compound 'A' shows that compound 'A' is alkene. Compound 'B' is  $C_4H_9Cl$ .

(ii) Compound 'B' reacts with  $NH_3$ , it forms amine 'C'.

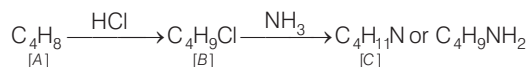

(iii) 'C' gives diazonium salt with  $NaNO_2 / HCl$ , which yields an optically active alcohol. So, 'C' is aliphatic amine.

(iv) 'A' on ozonolysis produces 2 moles of  $CH_3CHO$ . So, 'A' is  $CH_3 - CH = CH - CH_3$  (But-2-ene).

### Reactions

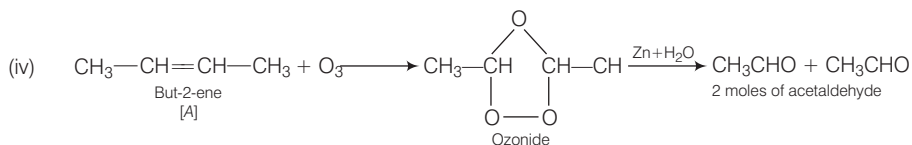
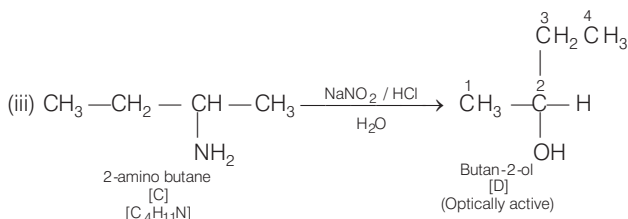
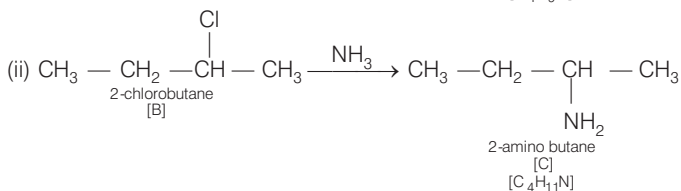
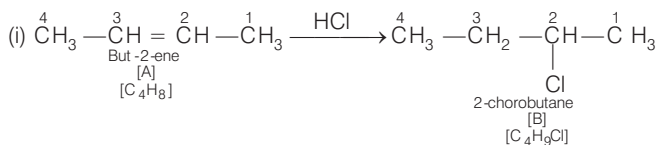

**Q. 76** A colourless substance 'A' ( $C_6H_7N$ ) is sparingly soluble in water and gives a water soluble compound 'B' on treating with mineral acid. On reacting with  $CHCl_3$  and alcoholic potash 'A' produces an obnoxious smell due to the formation of compound 'C'. Reaction of 'A' with benzenesulphonyl chloride gives compound 'D' which is soluble in alkali. With  $NaNO_2$  and HCl, 'A' forms compound 'E' which reacts with phenol in alkaline medium to give an orange dye 'F'. Identify compounds 'A' to 'F'.

### Thinking Process

This problem is based on chemical properties of aniline and property and solubility of their derivatives.

Ans.

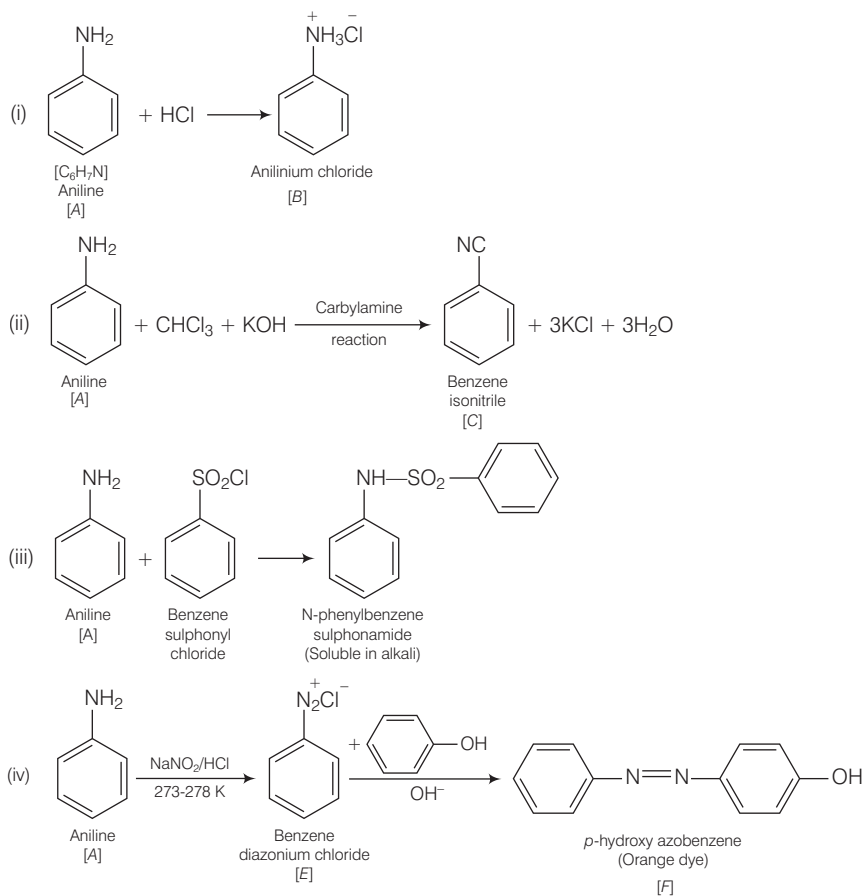

**Q. 77** Predict the reagent or the product in the following reaction sequence.

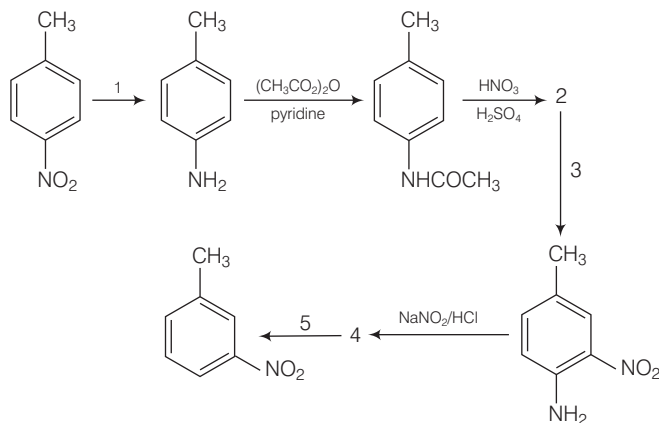

**Ans.** Correct sequence can be represented as follows including all reagents.

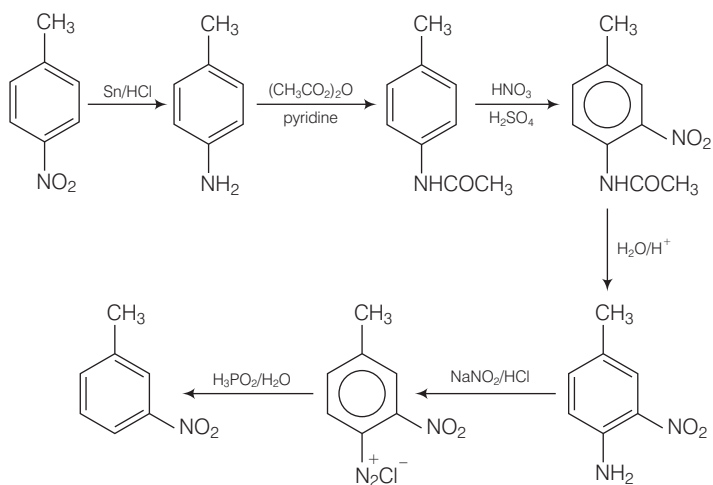

Hence,

(i) 1 =  $\text{Sn/HCl}$

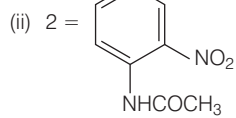

(iii) 3 =  $\text{H}_2\text{O/H}^+$

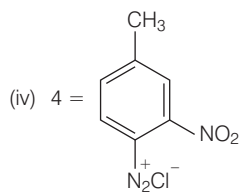

(v) 5 =  $\text{H}_3\text{PO}_2/\text{H}_2\text{O}$

# Biomolecules

## Multiple Choice Questions (MCQs)

**Q. 1** Glycogen is a branched chain polymer of  $\alpha$ -D glucose units in which chain is formed by C1—C4 glycosidic linkage where as branching occurs by the formation of C1—C6 glycosidic linkage. Structure of glycogen is similar to

.....

- (a) amylose (b) amylopectin (c) cellulose (d) glucose

**Ans. (b)** Glycogen is a branched chain polymer of  $\alpha$ -D glucose units in which chain is formed by C1—C4 glycosidic linkage whereas branching occurs by the formation of C1—C6 glycosidic linkage. Structure of glycogen can be shown below similar to the structure amylopectin.

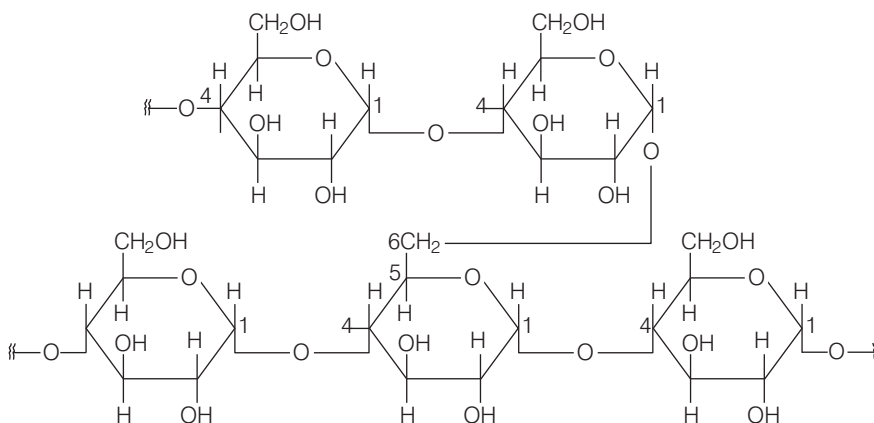

Structure of amylopectine

Glycogen is also known as animal starch present in liver, muscles and brain.

**Q. 2** Which of the following polymer is stored in the liver of animals?

- (a) Amylose (b) Cellulose (c) Amylopectin (d) Glycogen

**Ans. (d)** Glycogen is a polymer of  $\alpha$ -D glucose stored in the liver, brain and muscles of animals, also known as animal starch.

**Q. 3** Sucrose (cane sugar) is a disaccharide. One molecule of sucrose on hydrolysis gives .....

- (a) 2 molecules of glucose  
 (b) 2 molecules of glucose + 1 molecule of fructose  
 (c) 1 molecule of glucose + 1 molecule of fructose  
 (d) 2 molecules of fructose

**Ans. (c)** Sucrose (cane sugar) is a disaccharide. One molecule of sucrose on hydrolysis gives one molecule of glucose and one molecule of fructose.

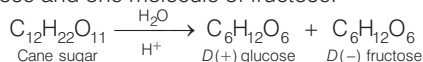

**Note** Sucrose is a dextro-rotatory sugar on hydrolysis produces a laevorotatory mixture so, known as invert sugar. Sucrose is a non-reducing sugar while maltose and lactose are reducing sugar.

**Q. 4** Which of the following pairs represents anomers?

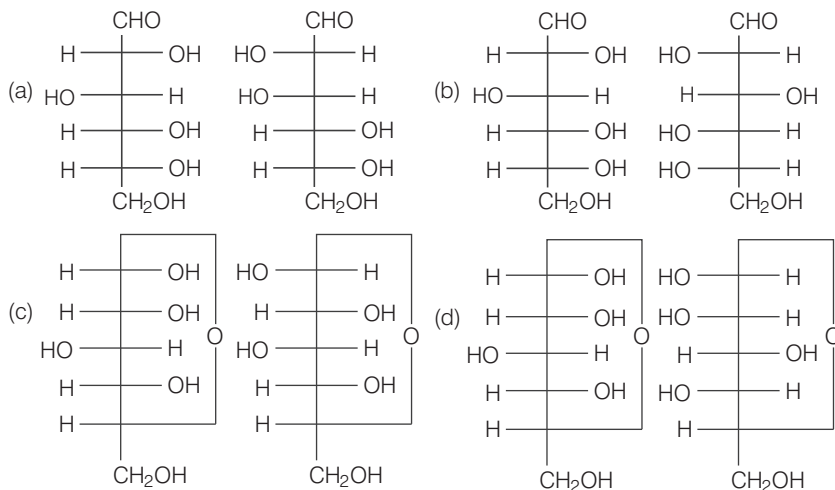

**Thinking Process**

This problem is based on the concept of anomer. Saccharides which differ in configuration at C-1 are known as anomers.

**Ans. (c)** Anomers have different configuration at C-1. If OH is present at right side anomeric carbon is known as  $\alpha$ - form and if OH is present at left side of anomeric carbon is known as  $\beta$ - form

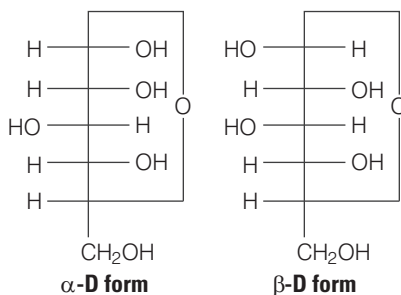

**Q. 5** Proteins are found to have two different types of secondary structures viz  $\alpha$ -helix and  $\beta$ -pleated sheet structure.  $\alpha$ -helix structure of protein is stabilised by

- (a) peptide bonds (b) van der Waals, forces  
(c) hydrogen bonds (d) dipole-dipole interactions

**Ans. (c)** Secondary structures of protein denotes the shape in which a long polypeptide chain exists. The secondary structure exist in two type of structure  $\alpha$ - helix and  $\beta$ - pleated structure.

In  $\alpha$ - helix structure, a polypeptide chain forms all possible hydrogen bonds by twisting into a right handed screw with —NH group of each amino acid rest hydrogen bonded to  $>C = O$  of adjacent amino acid, which form a helix.

**Q. 6** In disaccharides, if the reducing groups of monosaccharides, i.e., aldehydic or ketonic groups are bonded, these are non-reducing sugars. Which of the following disaccharide is a non-reducing sugar?

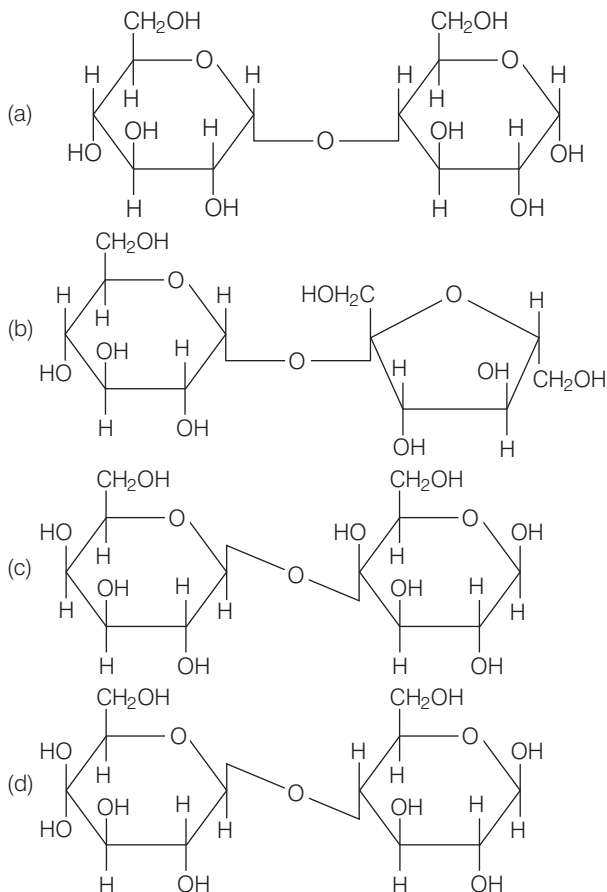



Ans. (b)

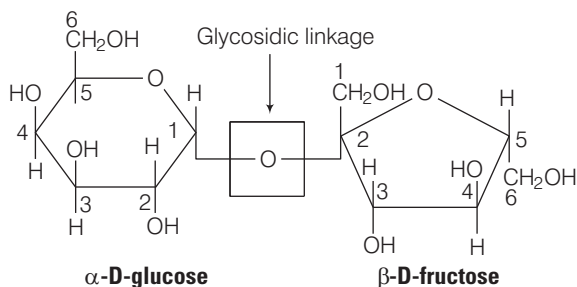

This structure represents sucrose in which  $\alpha$ -D glucose and  $\beta$ -D- fructose is attached to each other by  $C_1 - C_2$  glycosidic linkage.

Since, reducing groups of glucose and fructose are involved in glycosidic bond formation, this is considered as non-reducing sugar.

Q. 7 Which of the following acids is a vitamin?

- (a) Aspartic acid    (b) Ascorbic acid    (c) Adipic acid    (d) Saccharic acid

Ans. (b) Ascorbic acid is the chemical name of vitamin C. While others are not vitamins aspartic acid is an amino acid. Adipic acid is a dicarboxylic acid having 8 carbon chain. Saccharic acid is a dicarboxylic acid obtained by oxidation of glucose using  $HNO_3$ .

Q. 8 Dinucleotide is obtained by joining two nucleotides together by phosphodiester linkage. Between which carbon atoms of pentose sugars of nucleotides are these linkages present?

- (a) 5' and 3'    (b) 1' and 5'    (c) 5' and 5'    (d) 3' and 3'

Ans. (a) **Nucleoside** Species formed by the attachment of a base to 1' position of sugar is known as nucleoside. The sugar carbon are numbered as 1', 2', 3', ....to distinguish them from bases.

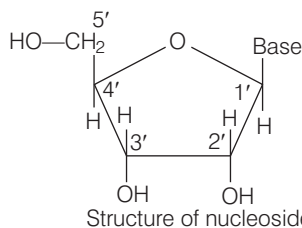

**Nucleotide** Species formed by attachment of phosphoric acid to nucleoside at 5' position of sugar nucleotide.

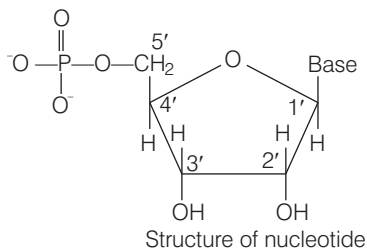

Dinucleotides are formed by phosphodiester linkage between 5' and 3' carbon atoms of the pentose sugar.

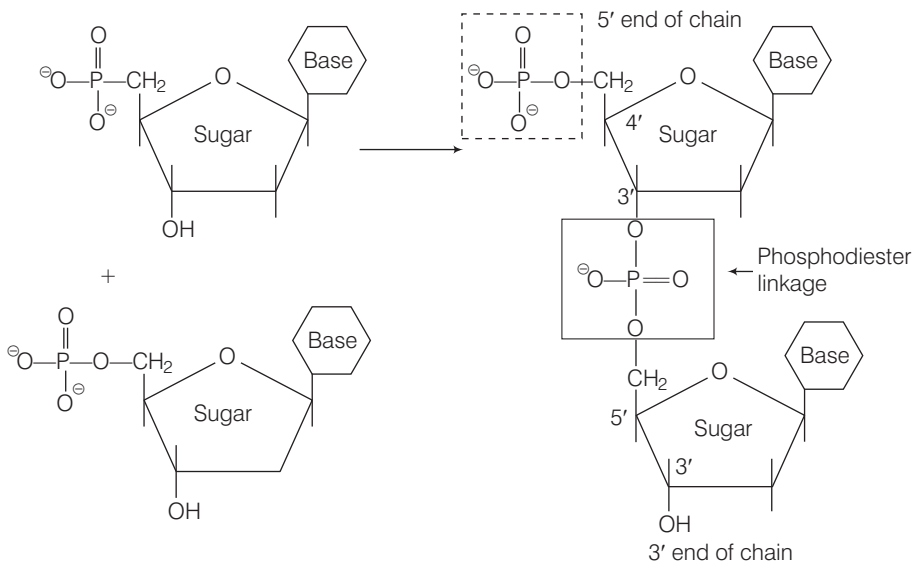

**Q. 9** Nucleic acids are the polymers of

- (a) nucleosides      (b) nucleotides      (c) bases      (d) sugars

**Ans. (b)** Nucleic acids are polymer of nucleotides in which nucleic acids are linked together by phosphodiester linkage.

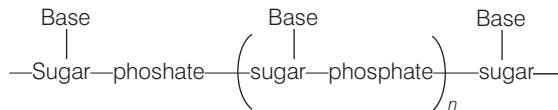

e.g., DNA, RNA etc.

**Q. 10** Which of the following statements is not true about glucose?

- (a) It is an aldohexose  
 (b) On heating with HI it forms *n*-hexane  
 (c) It is present in furanose form  
 (d) It does not give 2, 4- DNP test

**Ans. (c)** Glucose is a aldohexose having structural formula.

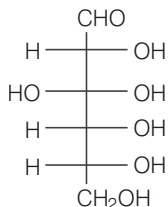

Glucose on heating with HI produces *n* hexane.



Glucose does not give 2, 4, DNP test due to its existence as cyclic structure shown below

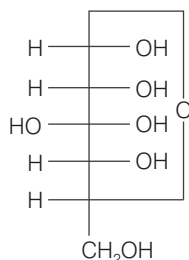

It is present in pyranose form, as shown below

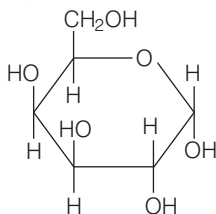

Pyranose means pyran (membered ring containing oxygen) like structure.

**Q. 11** Each polypeptide in a protein has amino acids linked with each other in a specific sequence. This sequence of amino acids is said to be .....

- (a) primary structure of proteins      (b) secondary structure of proteins  
(c) tertiary structure of proteins      (d) quaternary structure of proteins

**Ans. (a)** In primary structure of proteins when each polypeptide in a protein has amino acids linked with each other in a specific sequence. This type of structure is known as primary structure of proteins.

**Q. 12** DNA and RNA contain four bases each. Which of the following bases is not present in RNA?

- (a) Adenine      (b) Uracil      (c) Thymine      (d) Cytosine

**Ans. (c)** DNA contain four bases adenine, guanine, thymine and cytosine. While RNA contain four bases adenine, uracil, guanine and cytosine. Thus, RNA does not contain thymine.

Hence, statement (c) is the correct choice.

**Q. 13** Which of the following B group vitamins can be stored in our body?

- (a) Vitamin B<sub>1</sub>      (b) Vitamin B<sub>2</sub>      (c) Vitamin B<sub>6</sub>      (d) Vitamin B<sub>12</sub>

**Ans. (d)** Vitamin B<sub>12</sub> can be stored in our body belongs to B group vitamins, because it is not water soluble.

**Q. 14** Which of the following bases is not present in DNA?

- (a) Adenine      (b) Thymine      (c) Cytosine      (d) Uracil

**Ans. (d)** DNA contains following four bases

- (a) adenine (A)      (b) thymine (T)  
(c) guanine (G)      (d) cytosine (C)

It does not contain uracil.

**Q. 15** Three cyclic structures of monosaccharides are given below which of these are anomers.

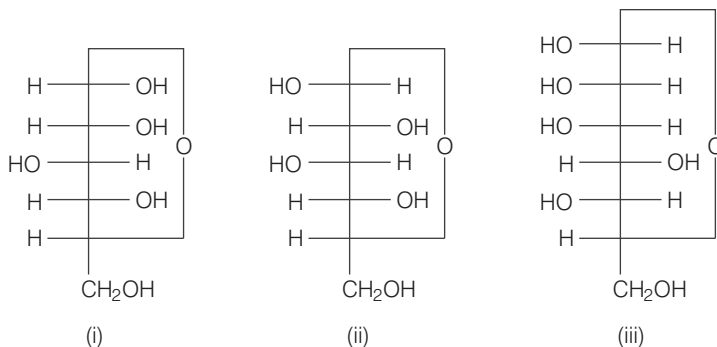

(a) I and II  
(c) I and III

(b) II and III  
(d) III is anomer of I and II

**Ans. (a) Anomers** Cyclic structures of monosaccharides which differ in structure at carbon-1 are known as anomers.

Here, I and II are anomer because they differ from each other at carbon- 1 only.

**Q. 16** Which of the following reactions of glucose can be explained only by its cyclic structure?

- (a) Glucose forms pentaacetate  
(b) Glucose reacts with hydroxylamine to form an oxime  
(c) Pentaacetate of glucose does not react with hydroxyl amine  
(d) Glucose is oxidised by nitric acid to gluconic acid

**Ans. (c)** "Pentaacetate of glucose does not react with hydroxylamine" showing absence of free CHO group. This can not be explained by open structure of glucose. While all other properties are easily explained by open structure of glucose.

Hence, option (c) is the correct choice.

**Q. 17** Optical rotations of some compounds alongwith their structures are given below which of them have D configuration.

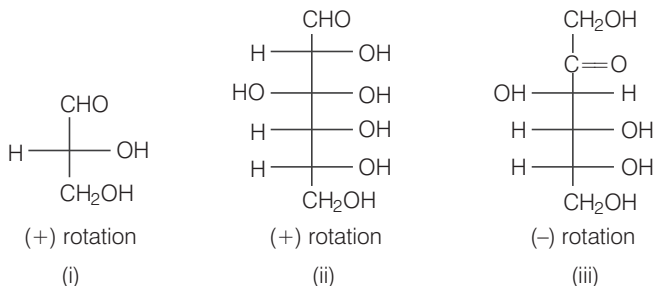

(a) I, II, III

(b) II, III

(c) I, II

(d) III

**Ans. (a)** *D* and *L* configuration are relative configuration decided by relating structure of given saccharide with *D* or *L* glyceraldehyde.

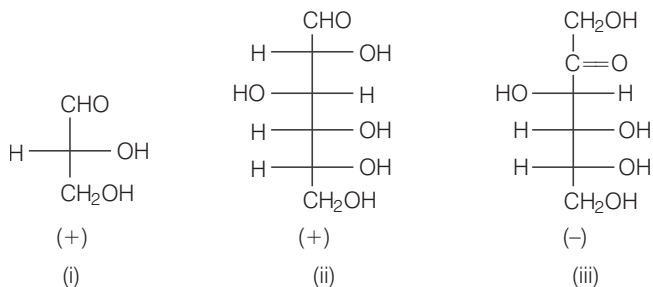

When OH on lowest asymmetric carbon is written at right hand side, it is represented as *D* configuration and when OH is written on left hand side, it is represented as *L* configuration.

**Q. 18** Structure of disaccharide formed by glucose and fructose is given below. Identify anomeric carbon atoms in monosaccharide units.

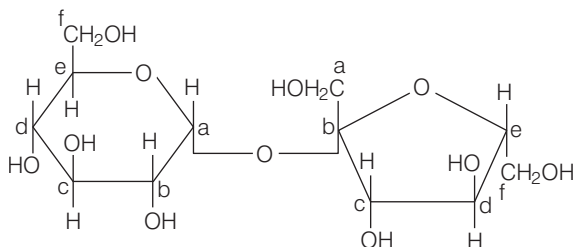

- (a) 'a' carbon of glucose and 'a' carbon of fructose  
 (b) 'a' carbon of glucose and 'e' carbon of fructose  
 (c) 'a' carbon of glucose and 'b' carbon of fructose  
 (d) 'f' carbon of glucose and 'f' carbon of fructose

**Ans. (c)** Carbon adjacent to oxygen atom in the cyclic structure of glucose or fructose is known as anomeric carbon. As shown in the structure above 'a' and 'b' are present at adjacent to oxygen atom. Both carbons differ in configurations of the hydroxyl group.

**Q. 19** Three structures are given below in which two glucose units are linked. Which of these linkages between glucose units are between  $C_1$  and  $C_4$  and which linkages are between  $C_1$  and  $C_6$ ?

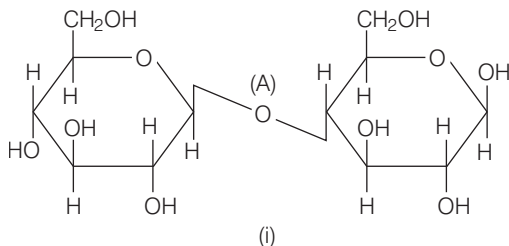

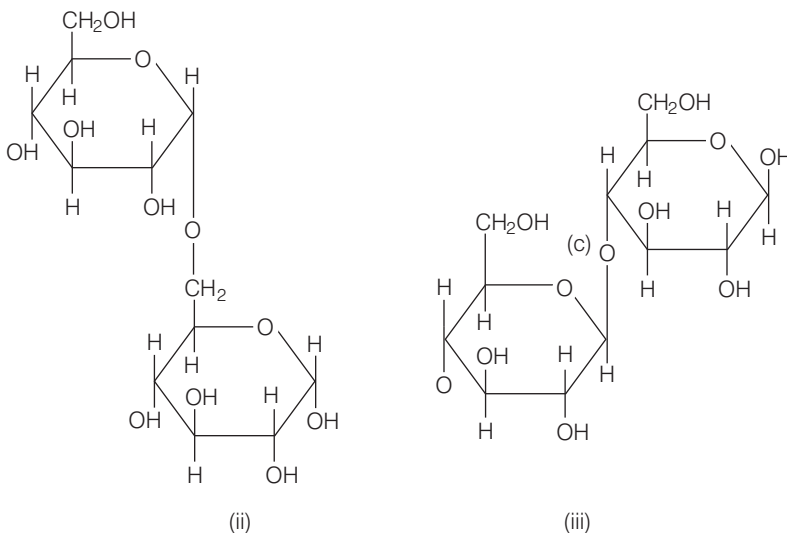

- (a) (A) is between C1 and C4 , (B) and (C) are between C1 and C6
- (b) (A) and (B) are between C1 and C4, (C) is between C1 and C6
- (c) (A) and (C) are between C1 and C4, (B) is between C1 and C6
- (d) (A) and (C) are between C1 and C6, (B) is between C<sub>1</sub> and C<sub>4</sub>

**Ans. (c)** Numbering of glucose starts from adjacent carbon of O-atom to the other carbon atom ending at last CH<sub>2</sub>OH group as shown below

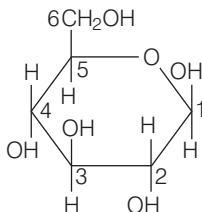

In this way, numbering for the disaccharides can be done as

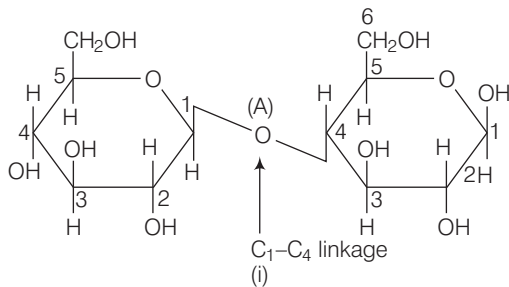

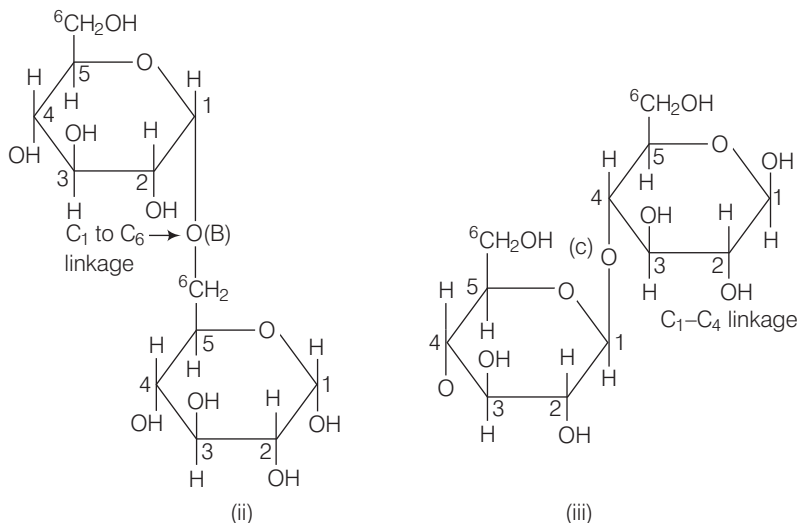

## Multiple Choice Questions (More Than One Options)

**Q. 20** Carbohydrates are classified on the basis of their behaviour on hydrolysis and also as reducing or non-reducing sugar. Sucrose is a .....

- (a) monosaccharide                      (b) disaccharide  
(c) reducing sugar                        (d) non-reducing sugar

**Ans. (b, d)**

Sucrose on hydrolysis produces equimolar mixture of  $\alpha$ -D(+) glucose and *B*-D(-)-fructose. Since in sucrose C — 1 of glucose and C — 2 of fructose are linked with each other So, they are non-reducing in nature.

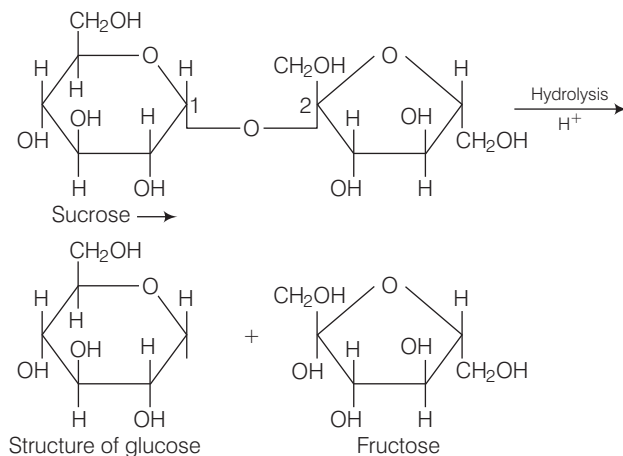

**Q. 21** Proteins can be classified into two types on the basis of their molecular shape, i.e., fibrous proteins and globular proteins. Examples of globular proteins are

- (a) insulin                      (b) keratin                      (c) albumin                      (d) myosin

**Ans. (a, c)**

The structure of protein which results when the chain of polypeptides coil around to give a spherical shape are known as globular protein. These proteins are soluble in water, e.g., insulin and albumin are globular protein.

Hence, (a) and (c) are correct choices.

**Q. 22** Which of the following carbohydrates are branched polymer of glucose?

- (a) Amylose                      (b) Amylopectin  
(c) Cellulose                      (d) Glycogen

**Ans. (b, d)**

Amylopectin and glycogen have almost similar structure in which glucose are linked linearly to each other by  $C_1 - C_4$  glycosidic linkage and branched at  $C_1 - C_6$  glycosidic linkage.

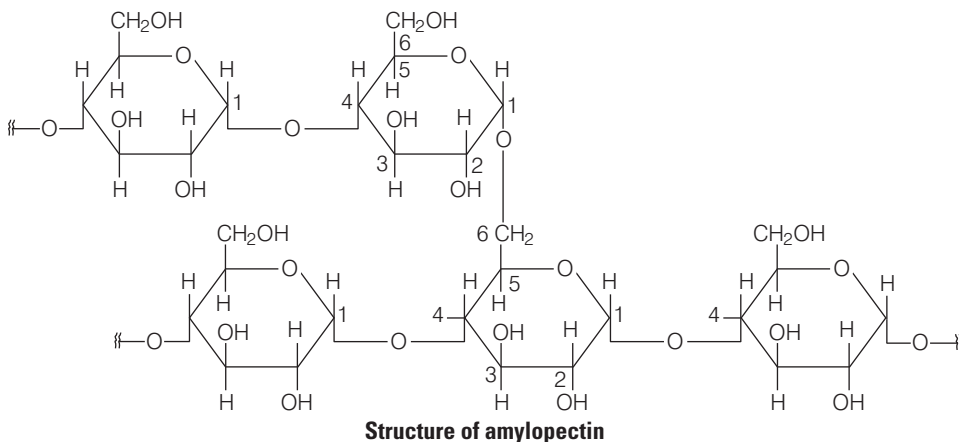

Glycogen are carbohydrates stored in animal body. The structure to similar to amylopectin and is rather more highly branched.

**Q. 23** Amino acids are classified as acidic, basic or neutral depending upon the relative number of amino and carboxyl groups in their molecule. Which of the following are acidic?

- (a)  $(CH_3)_2CH - \underset{\substack{| \\ NH_2}}{CH} - COOH$
- (b)  $HOOC - CH_2 - CH_2 - \underset{\substack{| \\ NH_2}}{CH} - COOH$
- (c)  $H_2N - CH_2 - CH_2 - CH_2 - COOH$
- (d)  $HOOC - CH_2 - \underset{\substack{| \\ NH_2}}{CH} - COOH$



### 💡 Thinking Process

This problem is based on concept of nature of amino acid, that either it is acidic, basic or neutral.

Depending upon the number of acidic COOH group, and basic  $\text{—NH}_2$  group amino acid, proteins can be classified as

(i) If number of COOH groups = number of  $\text{NH}_2$  groups, amino acid is neutral.

(ii) If number of COOH groups > number of  $\text{NH}_2$  groups, amino acid is acidic.

(iii) If number of COOH group < number of  $\text{NH}_2$  group, amino acid is basic.

### Ans. (b, d)

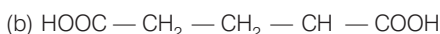

Number of COOH groups = 2

Number of  $\text{NH}_2$  group = 1

Since, number of COOH groups (2) > number of  $\text{NH}_2$  group (1). Therefore, this amino acid is acidic amino acid.

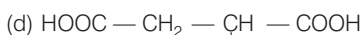

Number of COOH groups = 2

Number of  $\text{NH}_2$  groups = 1

Since, Number of COOH groups (2) > Number of  $\text{NH}_2$  groups (1). Therefore, amino acid is acidic. While other two are neutral amino acid as number of  $\text{NH}_2$  group is equal to number of COOH group in them.

**Q. 24** Lysine,  $\text{H}_2\text{N—(CH}_2\text{)}_4\text{—CH—COOH}$  is .....



(a)  $\alpha$ -amino acid

(b) basic amino acid

(c) amino acid synthesised in body

(d)  $\beta$ -amino acid

### Ans. (a, b, c)

Lysine whose structural formula is written below as

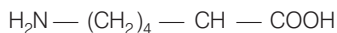

(a) It is an  $\alpha$  amino acid.

(b) It is a basic amino acid because number of  $\text{NH}_2$  groups (2) is greater than number of COOH group (1).

(c) It is a non-essential amino acid. Because it is synthesised in our body.

**Q. 25** Which of the following monosaccharides are present as five membered cyclic structure (furanose structure)?

(a) Ribose

(b) Glucose

(c) Fructose

(d) Galactose

### Ans. (a, c)

Ribose and fructose has five membered cyclic furanose structure because it include 5 carbon atom containing polyhydroxy carbonyl compound.

Hence (a) and (c) are correct choice.

**Q. 26** In fibrous proteins, polypeptide chains are held together by .....

- (a) van der Waals forces                      (b) disulphide linkage  
(c) electrostatic forces of attraction      (d) hydrogen bonds

**Ans. (b, d)**

In fibrous proteins, polypeptide chains are held together by hydrogen and disulphide bond, in parallel manner. Due to which fibre-like structure is obtained. Such proteins are generally known as fibrous proteins. These proteins are generally insoluble in water. e.g., Keratin, myosin.

**Q. 27** Which of the following are purine bases?

- (a) Guanine                      (b) Adenine                      (c) Thymine                      (d) Uracil

**Ans. (a, b)**

Purines consist of six membered and five membered nitrogen containing ring fused together.

Guanine and adenine are purine bases whose structures are

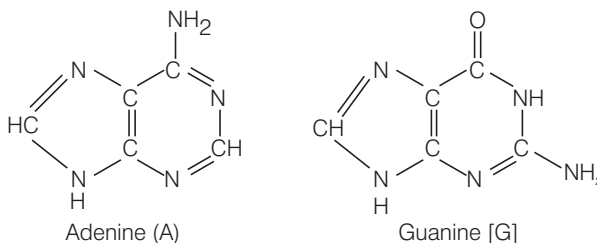

While thymine and uracil are pyrimidine bases.

Hence (a) and (b) are correct choices.

**Q. 28** Which of the following terms are correct about enzyme?

- (a) Proteins                      (b) Dinucleotides                      (c) Nucleic acids                      (d) Biocatalysts

**Ans. (a, d)**

Enzymes are proteins which acts as biocatalyst having specific role/action in specific biochemical reaction.

e.g., (i) Maltase decomposes maltose to glucose.



## Short Answer Type Questions

**Q. 29** Name the sugar present in milk. How many monosaccharide units are present in it? What are such oligosaccharides called?

**Ans.** Sugar present in milk is known as lactose sugar. Two units of monosaccharides  $\beta$ -D-galactose and  $\beta$ -D-glucose are linked together.

Hence, are known as disaccharides.

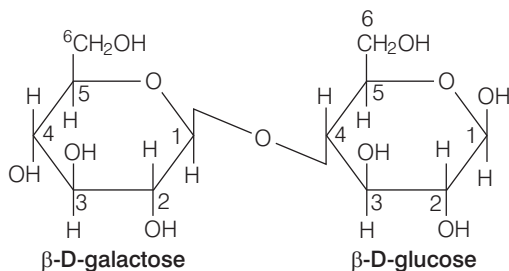

**Q. 30** How do you explain the presence of all the six carbon atoms in glucose in a straight chain?

**Ans.** Glucose on heating with HI produces *n*-hexane.

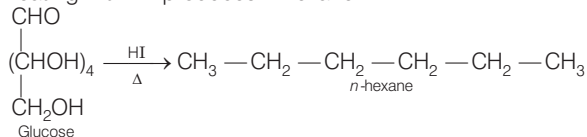

This suggests that all the six carbon atoms of glucose are linked in a straight chain.

**Q. 31** In nucleoside, a base is attached at 1' position of sugar moiety. Nucleotide is formed by linking of phosphoric acid unit to the sugar unit of nucleoside. At which position of sugar unit is the phosphoric acid linked in a nucleoside to give a nucleotide?

**Ans.** Phosphoric acid is linked at 5' position of sugar moiety of nucleoside to give a nucleotide.

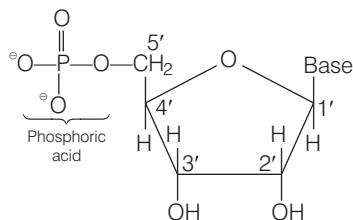

**Q. 32** Name the linkage connecting monosaccharide units in polysaccharides.

**Ans.** Glycosidic linkage connects monosaccharide units in polysaccharides.

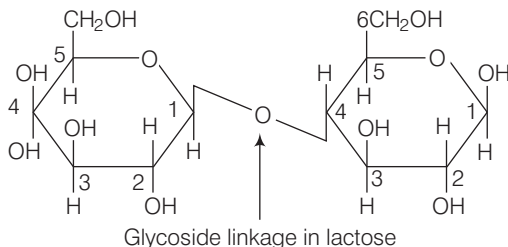

**Q. 33** Under what conditions glucose is converted to gluconic acid and saccharic acid?

**Ans.** Glucose on oxidation with  $\text{Br}_2 / \text{H}_2\text{O}$  produces gluconic acid (six carbon carboxylic acid).

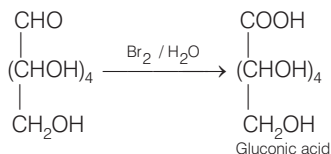

Glucose on oxidation with nitric acid produces saccharic acid. (dicarboxylic acid)

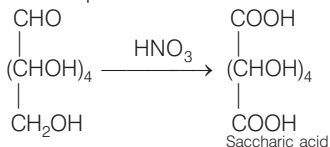

**Q. 34** Monosaccharides contain carbonyl group hence are classified, as aldose or ketose. The number of carbon atoms present in the monosaccharide molecule are also considered for classification. In which class of monosaccharide will you place fructose?

**Ans.** Monosaccharides contain carbonyl group.

Hence, are classified as aldose or ketose.

When aldehyde group is present, the monosaccharides are known as aldose.

When ketone group is present, the monosaccharides are known as ketose. Fructose has molecular formula  $\text{C}_6\text{H}_{12}\text{O}_6$  containing 6 carbon and keto group and is classified as ketohexose.

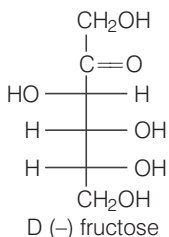

- Q. 35** The letters 'D' or 'L' before the name of a stereoisomer of a compound indicate the correlation of configuration of that particular stereoisomer. This refers to their relation with one of the isomers of glyceraldehyde. Predict whether the following compound has 'D' or 'L' configuration.

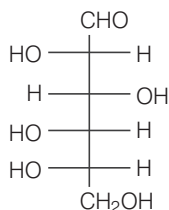

**Thinking Process**

This problem is based on relative configuration i.e., D and L configuration. This can be done by relating structure of monosaccharides with structure of glyceraldehyde.

If OH is present at right side of second last carbon of monosaccharide is considered as D configuration.

If OH is present at left side of second last carbon of monosaccharide is considered as L configuration.

- Ans.** Here, OH group present on second last carbon in at left side hence this has L configuration.

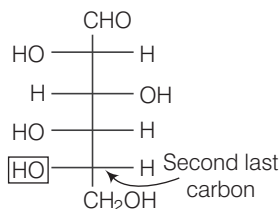

- Q. 36** Aldopentoses named as ribose and 2-deoxyribose are found in nucleic acids. What is their relative configuration?

**Ans.**

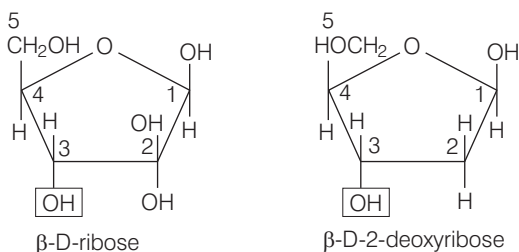

In case of cyclic structure of saccharide, if — OH group present at second last carbon is present at bottom side, then it is considered as D configuration (as shown above)

- Q. 37** Which sugar is called invert sugar? Why is it called so?

**Ans.** Sucrose is dextrorotatory but sucrose on hydrolysis gives dextrorotatory glucose and laevorotatory fructose. Hence, mixture becomes laevorotatory.

This sugar which on hydrolysis changes its sign of rotation from dextro to laevo is known as invert sugar.

**Q. 38** Amino acids can be classified as  $\alpha$ -,  $\beta$ -,  $\gamma$ -,  $\delta$ - and so on depending upon the relative position of amino group with respect to carboxyl group. Which type of amino acids form polypeptide chain in proteins?

**Ans.**  $\alpha$  amino acid forms polypeptide chain by elimination of water molecules.

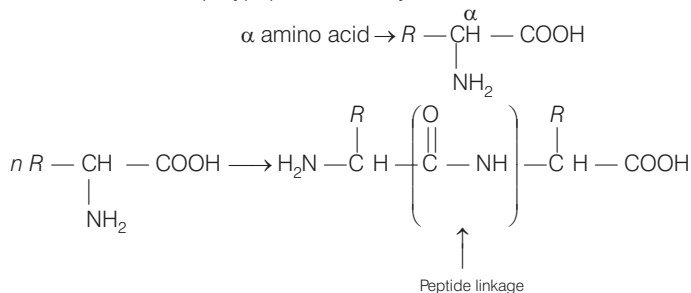

**Q. 39**  $\alpha$ -helix is a secondary structure of proteins formed by twisting of polypeptide chain into right handed screw like structure. Which type of interactions are responsible for making the  $\alpha$ -helix structure stable?

**Ans.**  $\alpha$ -helix is a secondary structure of proteins formed by twisting of polypeptide chain to right handed screw like structure. Hydrogen bonds formed between  $-\text{NH}-$  group of amino acids in one turn with the  $>\text{C}=\text{O}$  groups of amino acids belonging to adjacent turn is responsible for making the  $\alpha$ -helix structure stable.

**Q. 40** Some enzymes are named after the reaction, where they are used. What name is given to the class of enzymes which catalyse the oxidation of one substrate with simultaneous reduction of another substrate?

**Ans. Oxidoreductase enzymes** A class of enzymes which catalyses the oxidation of one substrate with simultaneous reduction of another substrate is known as oxidoreductase enzymes.

**Q. 41** During curdling of milk, what happens to sugar present in it?

**Ans.** Curdling of milk is caused due to formation of lactic acid by the bacteria present in milk. It is an example of denaturation of protein, i.e., when a protein is subjected to some physical or chemical changes. Hydrogen bonds get disturbed. Globules unfold and helix uncoil and protein loses its biological activity.

**Q. 42** How do you explain the presence of five  $-\text{OH}$  groups in glucose molecule?

**Ans.** Glucose on reaction with acetic anhydride produces glucose pentaacetate.

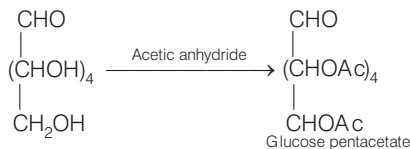

This reaction explains the presence of five  $-\text{OH}$  groups.

**Q. 43** Why does compound (A) given below not form an oxime?

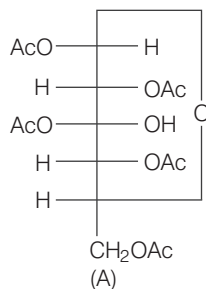

**Ans.** Compound (A) does not form an oxime on reaction with  $\text{NH}_2\text{OH}$  due to absence of CHO group or  $>\text{C}=\text{O}$  group.

**Q. 44** Why must vitamin C be supplied regularly in diet?

**Ans.** Vitamin C is water soluble hence, they are regularly excreted in urine and can not be stored in our body, so, they are supplied regularly in diet.

**Q. 45** Sucrose is dextrorotatory but the mixture obtained after hydrolysis is laevorotatory. Explain.

**Ans.** Sucrose is dextrorotatory. On hydrolysis, it produces a mixture of glucose and fructose having specific rotation  $+52.5^\circ$  and  $-92.4^\circ$ . Thus, the respectively net resultant mixture become laevorotatory.

Hence, the mixture is laevorotatory and product is known as invert sugar.

**Q. 46** Amino acids behave like salts rather than simple amines or carboxylic acids. Explain.

**Ans.** Amino acids have acidic COOH group as well as  $\text{NH}_2$  group hence, COOH loses its H to  $\text{NH}_2$ , hence they exist as Zwitter ion.

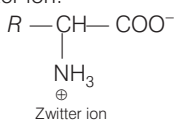

**Q. 47** Structures of glycine and alanine are given below. Show the peptide linkage in glycyalanine.

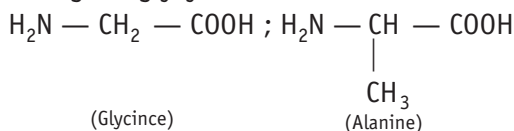

**Ans.** Glycine and alanine on reaction with each other produces glycyalanine as

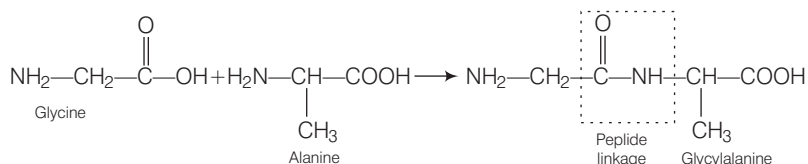

**Q. 48** Protein found in a biological system with a unique three-dimensional structure and biological activity is called a native protein. When a protein in its native form, is subjected to a physical change like change in temperature or a chemical change like, change in pH, denaturation of protein takes place. Explain the cause.

**Ans.** Due to physical and chemical change, hydrogen bonds in proteins are disturbed. Due to this globules unfold and helix gets uncoiled and therefore, protein loses its biological activity. This is known as denaturation of **proteins**.

**Q. 49** Activation energy for the acid catalysed hydrolysis of sucrose is  $6.22 \text{ kJ mol}^{-1}$ , while the activation energy is only  $2.15 \text{ kJ mol}^{-1}$  when hydrolysis is catalysed by the enzyme sucrase. Explain.

**Ans.** Enzymes, the biocatalysts reduce the magnitude of activation energy by providing alternative path. In the hydrolysis of sucrose, the enzyme sucrase reduces the activation energy from  $6.22 \text{ kJ mol}^{-1}$  to  $2.15 \text{ kJ mol}^{-1}$ .

**Q. 50** How do you explain the presence of an aldehydic group in a glucose molecule?

**Ans.** Glucose on reaction with bromine water produces gluconic acid. This indicates the presence of CHO group.

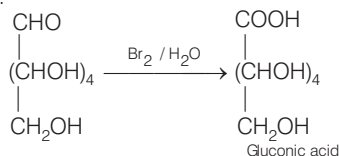

**Q. 51** Which moieties of nucleosides are involved in the formation of phosphodiester linkages present in dinucleotides? What does the word diester in the name of linkage indicate? Which acid is involved in the formation of this linkage?

**Ans.** (i) 5' and 3' carbon atoms of pentose sugar.

(ii) Most probably the resemblance of with 2 ester ( $-\text{COO}^-$ )<sup>2-</sup> groups joined together.

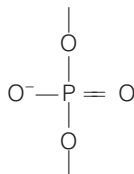



(iii) Phosphoric acid ( $\text{H}_3\text{PO}_4$ ).

Nucleosides are joined together by phosphodiester linkage between 5' and 3' carbon atoms of pentose sugar and a dinucleotide with phosphoric acid ( $\text{CH}_3\text{PO}_4$ ) is formed

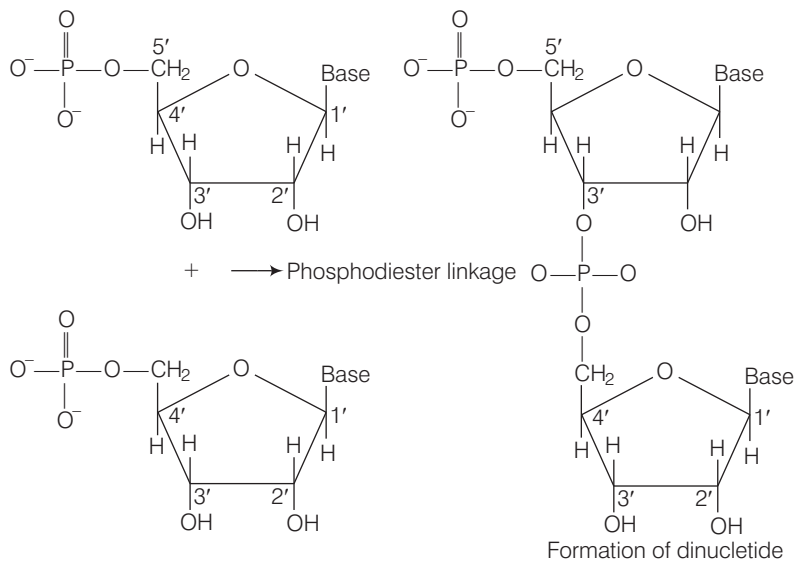

**Q. 52** What are glycosidic linkages? In which type of biomolecules are they present?

**Ans.** Linkage between two monosaccharides due to oxide linkage formed by the loss of a water molecule, is known as glycosidic linkage as shown below

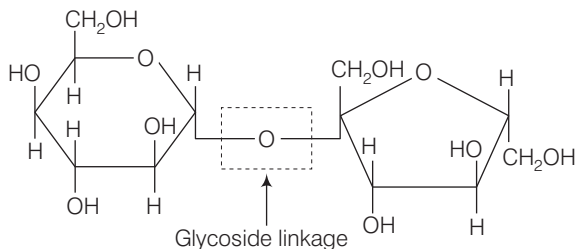

**Q. 53** Which monosaccharide units are present in starch, cellulose and glucose and which linkages link these units?

**Ans.** Monosaccharides units present in starch, cellulose and glucose can be determined by knowing the product of their hydrolysis.

- (i) Starch is a polysaccharide of  $\alpha$ -glucose in which two types of linkage are observed *i.e.*,  $\text{C}_1 - \text{C}_6$  and  $\text{C}_1 - \text{C}_4$  glycosidic linkage.
- (ii) Cellulose is a straight chain polysaccharide of  $\beta$ -D glucose in which glucose are linked together by  $\text{C}_1 - \text{C}_4$  glycosidic linkage.
- (iii) Glucose is a monosaccharide.

**Q. 54** How do enzymes help a substrate to be attacked by the reagent effectively?

**Ans.** At the surface of enzyme, active sites are present. These active sites of enzymes hold the substrate molecule in a suitable position, so that it can be attacked by the reagent effectively. This reduces the magnitude of activation energy.

Enzymes contains cavities of characteristics shape and possessing active groups known as active centre on the surface. The molecules of the reactant (substrate) having complementary shape, fit into these cavities. On account of these active groups, an activated complex is formed which then decomposes to yield the products.

**Q. 55** Describe the term D- and L-configuration used for amino acids with examples.

**Ans.** All naturally occurring  $\alpha$ -amino acids (except glycine) are optically active due to the presence of chiral carbon atom. These have either *D*- or *L*-configuration. *D*-form means that, the amino ( $-\text{NH}_2$ ) group is present towards the right hand side. *L*-form shows the presence of  $-\text{NH}_2$  group on the left hand side.

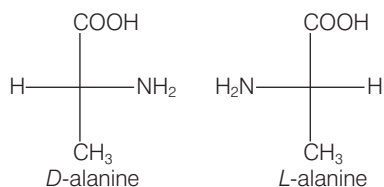

**Q. 56** How will you distinguish  $1^\circ$  and  $2^\circ$  hydroxyl groups present in glucose? Explain with reactions.

**Ans.**  $1^\circ$  and  $2^\circ$  hydroxyl groups present in glucose can be identified by the reaction of glucose with nitric acid. Primary OH group present in glucose are easily oxidised to  $-\text{COOH}$  group while secondary OH group does not.

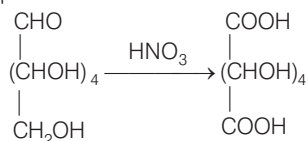

Hence, one OH is primary OH group.

**Q. 57** Coagulation of egg white on boiling is an example of denaturation of protein. Explain it in terms of structural changes.

**Ans. Denaturation of proteins** Protein present in egg white has an unique three dimensional structure. When it is subjected to physical change like change in temperature. *i.e.*, on boiling, coagulation of egg white occurs due to denaturation of protein.

During denaturation hydrogen bonds are disturbed due to this globules unfold and helix gets uncoiled and protein loses its biological activity.

## Matching The Columns

**Q. 58** Match the vitamins given in Column I with the deficiency disease they cause given in Column II.

Column I (Vitamins)	Column II (Diseases)
A. Vitamin A	1. Pernicious anaemia
B. Vitamin B <sub>1</sub>	2. Increased blood clotting time
C. Vitamin B <sub>12</sub>	3. Xerophthalmia
D. Vitamin C	4. Rickets
E. Vitamin D	5. Muscular weakness
F. Vitamin E	6. Night blindness
G. Vitamin K	7. Beri-beri
	8. Bleeding gums
	9. Osteomalacia

**Ans.** A. → (3, 6)    B. → (7)    C. → (1)    D. → (8)    E. → (4, 9)    F. → (5)    G. → (2)

Column I (Vitamins)	Column II (Diseases)
A. Vitamin A	Xerophthalmia Night blindness
B. Vitamin B <sub>1</sub>	Beri beri
C. Vitamin B <sub>12</sub>	Pernicious anaemia
D. Vitamin C	Bleeding gums
E. Vitamin D	Rickets Osteomalacia
F. Vitamin E	Muscular weakness
G. Vitamin K	Increased blood clotting time

**Q. 59** Match the following enzymes given in Column I with the reactions they catalyse given in Column II.

Column I (Enzymes)	Column II (Reactions)
A. Invertase	1. Decomposition of urea into NH <sub>3</sub> and CO <sub>2</sub> .
B. Maltase	2. Conversion of glucose into ethyl alcohol.
C. Pepsin	3. Hydrolysis of maltose into glucose.
D. Urease	4. Hydrolysis of cane sugar.
E. Zymase	5. Hydrolysis of proteins into peptides.

**Ans.** A. → (4)    B. → (3)    C. → (5)    D. → (1)    E. → (2)

Column I (Enzymes)	Column II (Reaction)
A. Invertase	Hydrolysis of cane sugar.
B. Maltase	Hydrolysis of maltose into glucose.
C. Pepsin	Hydrolysis of protein into peptides.
D. Urease	Decomposition of urea into NH <sub>3</sub> and CO <sub>2</sub>
E. Zymase	Conversion of glucose into ethyl alcohol.

## Assertion and Reason

In the following questions a statement of Assertion (A) followed by a statement of Reason (R) is given. Choose the correct answer out of the following choices.

- Assertion and reason both are correct statements and reason explains the assertion.
- Both assertion and reason are wrong statements.
- Assertion is correct statement and reason is wrong statement.
- Assertion is wrong statement and reason is correct statement.
- Assertion and reason both are correct statements but reason does not explain assertion.

**Q. 60 Assertion (A)** D (+) – Glucose is dextrorotatory in nature.

**Reason (R)** 'D' represents its dextrorotatory nature.

**Ans. (c)** Assertion is correct but reason is wrong statement D (+) glucose is dextrorotatory because it rotates the plane polarised light to right.

Here, D represents relative configuration of glucose with respect to glyceraldehyde.

**Q. 61 Assertion (A)** Vitmin D can be stored in our body.

**Reason (R)** Vitamin D is fat soluble vitamin.

**Ans. (a)** Assertion and reason both are correct statements and reason explains assertion. Vitamin D can be stored in our body because vitamin D is fat soluble vitamin.

**Q. 62 Assertion (A)**  $\beta$ -glycosidic linkage is present in maltose.

**Reason (R)** Maltose is composed of two glucose units in which C- 1 of one glucose unit is linked to C- 4 of another glucose unit.

**Ans. (d)** Assertion is wrong statement and reason is correct statement.  $\alpha$ -glycosidic linkage is present in maltose

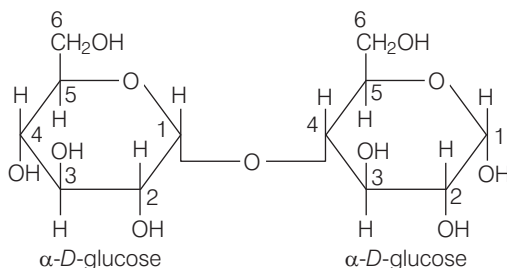

Because maltose is composed of two glucose unit in which C-1 of one glucose unit is linked to C-4 of another glucose unit.

**Q. 63 Assertion (A)** All naturally occurring  $\alpha$ -aminoacids except glycine are optically active.

**Reason (R)** Most naturally occurring amino acids have L-configuration.

**Ans. (e)** Assertion and reason both are correct and reason does not explain assertion. All naturally occurring  $\alpha$ -amino except glycine are optically active.

Glycine is optically inactive because glycine does not have all four different substituents as shown below.

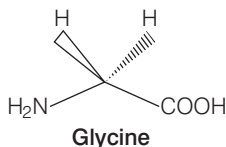

**Q. 64 Assertion (A)** Deoxyribose,  $C_5H_{10}O_4$  is not a carbohydrate.

**Reason (R)** Carbohydrates are hydrates of carbon so compounds which follow  $C_x(H_2O)_y$  formula are carbohydrates.

**Ans. (b)** Both assertion and reason are wrong statements. Deoxyribose  $C_5H_{10}O_4$  is a carbohydrate because it follows  $C_5(H_2O)_2$  formula and exists as a polyhydroxy carbonyl compound whose cyclic structure is as shown below

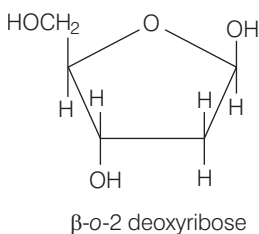

**Q. 65 Assertion (A)** Glycine must be taken through diet.

**Reason (R)** It is an essential amino acid.

**Ans. (b)** Both assertion and reason are wrong statements. Correct assertion and reason are Glycine must not be taken through diet because it can be synthesised in our body and is a non-essential amino acid.

**Q. 66 Assertion (A)** In presence of enzyme, substrate molecule can be attacked by the reagent effectively.

**Reason (R)** Active sites of enzymes hold the substrate molecule in a suitable position.

**Ans. (a)** Assertion and reason both are correct and reason explains assertion. In presence of enzyme, substrate molecule can be attacked by a reagent effectively because active sites of enzymes hold the substrate molecule in a suitable position. So, enzyme catalysed reactions are stereospecific reactions.

## Long Answer Type Questions

**Q. 67** Write the reactions of D-glucose which can't be explained by its open chain structure. How can cyclic structure of glucose explain these reactions?

- Ans.** Chemical reactions of D-glucose which can't be explained by its open chain structure are
- Glucose does not give Schiff's test and does not produce hydrogensulphite addition product with  $\text{NaHSO}_3$ , despite having aldehyde group
  - The pentaacetate of glucose does not react with hydroxylamine.

In actual, glucose exist in two different crystalline form  $\alpha$  form and  $\beta$  form. It was proposed that one of the OH groups may add to the  $\text{—CHO}$  group and form cyclic hemiacetal structure. Glucose forms a 6 membered pyranose structure.

Cyclic structure exist in equilibrium with open structure and can be represented as

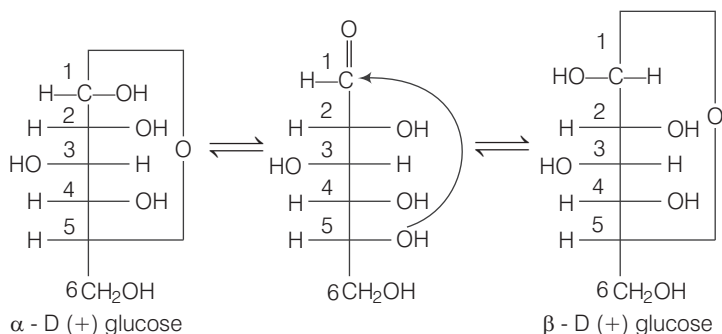

Due to formation of cyclic structure of glucose CHO group of glucose remain no longer free due to which they do not show above given reactions.

**Q. 68** On the basis of which evidences D-glucose was assigned the following structure?

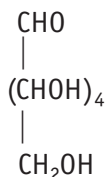

**Ans.** Evidences on the basis of which glucose was assigned the following structure are as follows

- Glucose on reaction with HI produces *n* hexane which indicates presence of six carbon atom linked in a having straight chain.

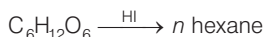

- Glucose on reaction with acetic anhydride produces glucose penta acetate which indicates presence of five OH groups.



- Glucose on oxidation with bromine water produces gluconic acid indicates presence of  $\text{—CHO}$  group.

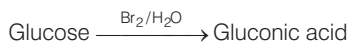

- Glucose on reaction with  $\text{HNO}_3$  produces saccharic acid which indicates presence of one primary OH group.

**Q. 69** Carbohydrates are essential for life in both plants and animals. Name the carbohydrates that are used as storage molecules in plants and animals, also name the carbohydrate which is present in wood or in the fibre of cotton cloth.

**Ans.** Carbohydrates that are used as storage molecules in plants and animals are as follows

- Plant contains mainly starch, cellulose, sucrose etc.
- Animal contain glycogen in their body. So, glycogen is also known as animal starch. Glycogen is present in liver, muscles and brain when body needs glucose, enzyme breaks glycogen down to glucose.
- Cellulose is present in wood, and fibre of clothes.

**Q. 70** Explain the terms primary and secondary structure of proteins. What is the difference between  $\alpha$ -helix and  $\beta$ -pleated sheet structure of proteins?

**Ans. Primary structure of proteins** Proteins consist of one or more polypeptide chains. Each polypeptide is a protein contains **amino acids** joined with each other in a **specific sequence**. **Secondary structure of proteins** It refers to the **shape** in which a **long polypeptide chain** can exist.

$\alpha$ -helix structure	$\beta$ -pleated sheet structure
A structure of twisting of all a polypeptide chain formed by possible H-bonds into a right handed screw (helix) with the —NH group of each amino acid, and residue hydrogen bonded to the —CO— of an adjacent turn of the helix. Hence, called $\alpha$ -helix.	All peptide chains are stretched out to nearly maximum extension and then laid side by side which are held together by intermolecular hydrogen bonds. This structure resembles the pleated folds of the drapery. Hence, called $\beta$ -pleated sheet structure.

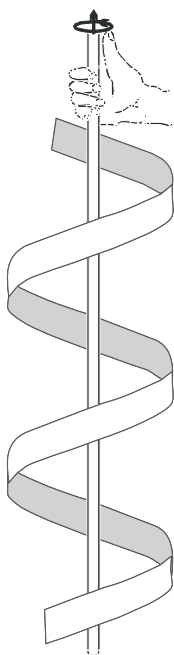

$\alpha$ -helix structure of proteins

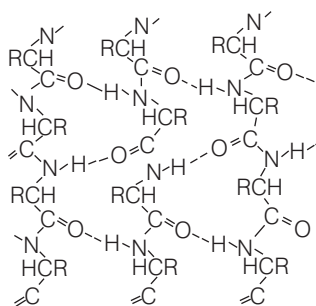
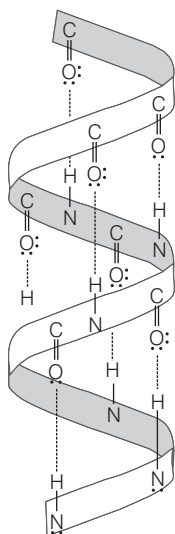

$\beta$ -pleated sheet structure of proteins

**Q. 71** Write the structures of fragments produced on complete hydrolysis of DNA. How are they linked in DNA molecule? Draw a diagram to show pairing of nucleotide bases in double helix of DNA.

**Ans.** On complete hydrolysis of DNA, following fragments are formed a pentose sugar ( $\beta$ -D-2-deoxyribose) phosphoric acid ( $H_3PO_4$ ) and bases (nitrogen containing heterocyclic compounds).

**Structures**

(i) **Sugar**

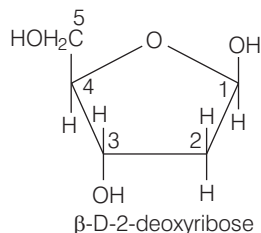

(ii) **Phosphoric acid**

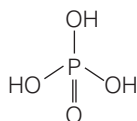

(iii) **Nitrogen bases** DNA contains four bases

Adenine (A), Guanine (G), Cytosine (C) and thymine (T).

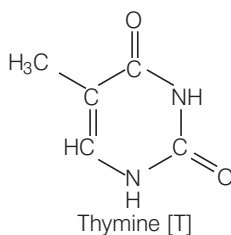
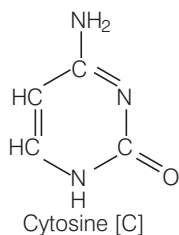
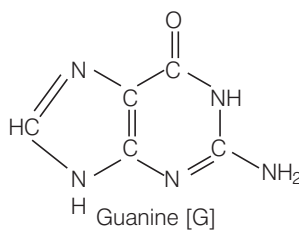
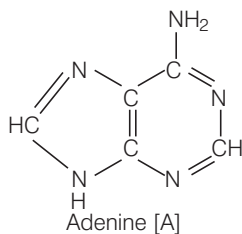

A unit formed by the attachment of a base to 1'-position of sugar is called **nucleoside**. When nucleoside links to phosphoric acid at 5'-position of sugar moiety, a **nucleotide** is formed. Nucleotides are joined together by phosphodiester linkage between 5' and 3' carbon atoms of the pentose sugar.

In DNA two nucleic acid chains are wound about each other and held together by hydrogen bonds between pairs of bases.



The two strands are complementary to each other because hydrogen bonds are formed between specific pair of base adenine form hydrogen bonds with thymine whereas cytosine form hydrogen bonds with guanine.

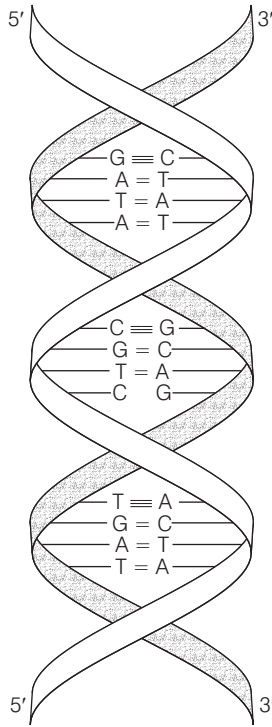

**Double stranded helix structure of DNA**

# 15

## Polymer

### Multiple Choice Questions (MCQs)

**Q. 1** Which of the following polymers of glucose is stored by animals?

- (a) Cellulose (b) Amylose  
(c) Amylopectin (d) Glycogen

**Ans. (d)** Glycogen is a polymer of glucose found in liver, brain and muscles of animals. Cellulose is a polymer found in plant while amylose and amylopectin are structural units of starch.

**Q. 2** Which of the following is not a semisynthetic polymer?

- (a) *cis*-polyisoprene  
(b) Cellulose nitrate  
(c) Cellulose acetate  
(d) Vulcanised rubber

**Ans. (a)** *cis*-polyisoprene is not a semisynthetic polymer while other three cellulose nitrate, cellulose acetate and vulcanised rubber are semisynthetic polymer made from cellulose, cellulose and natural rubber respectively.

**Q. 3** The commercial name of polyacrylonitrile is .....

- (a) dacron (b) orlon (acrilan) (c) PVC (d) bakelite

**Ans. (b)** The commercial name of polyacrylonitrile is orlon (acrilan).

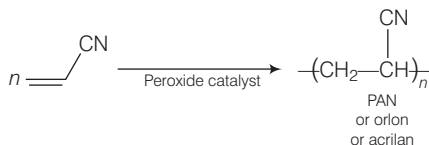

**Q. 4** Which of the following polymer is biodegradable?

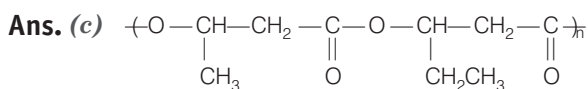
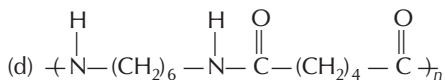
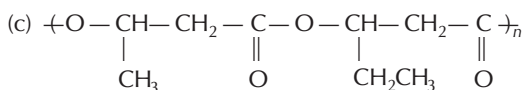
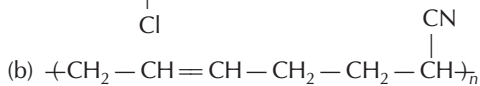
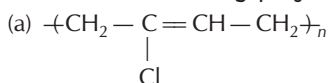

Poly  $\beta$ -hydroxybutyrate - co- $\beta$ -hydroxy valerate is an example of biodegradable polymer.

**Q. 5** In which of the following polymers ethylene glycol is one of the monomer units?

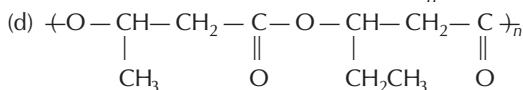
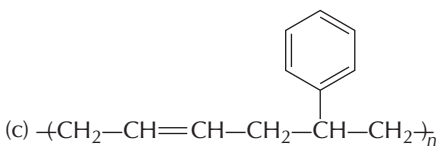
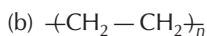
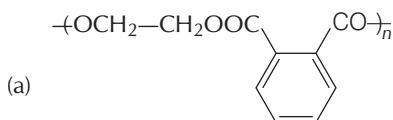

**Ans. (a)** Given polymer can be obtained condensation polymerisation of ethylene glycol and phthalic acid with the elimination of water molecule.

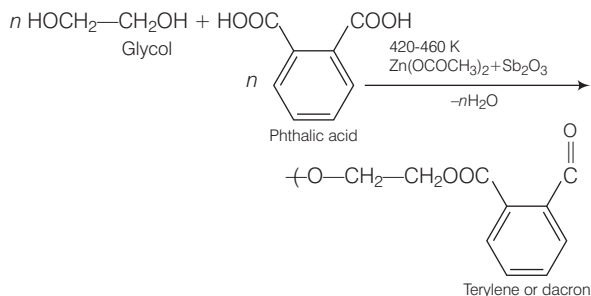

**Q. 6** Which of the following statements is not true about low density polyethene?

- (a) Tough (b) Hard  
(c) Poor conductor of electricity (d) Highly branched structure

**Ans. (d)** Low density polyethene has slightly branched but not highly branched structure.

**Q. 7**  $\left[ \text{CH}_2 - \underset{\text{CH}_3}{\overset{\text{CH}_3}{\text{C}}} - \text{CH}_2 - \underset{\text{CH}_3}{\overset{\text{CH}_3}{\text{C}}} \right]_n$  is a polymer having monomer units .....

- (a)  $\text{>C=C<}$  (b)  $\text{>C=C}$  (c)  $\text{>C=C(H)H}$  (d)  $\text{>C=C<}$

**Ans. (a)**  $\left[ \text{CH}_2 - \underset{\text{CH}_3}{\overset{\text{CH}_3}{\text{C}}} - \text{CH}_2 - \underset{\text{CH}_3}{\overset{\text{CH}_3}{\text{C}}} \right]_n$  can be obtained by addition polymerisation of  $\text{>C=C<}$  as shown below

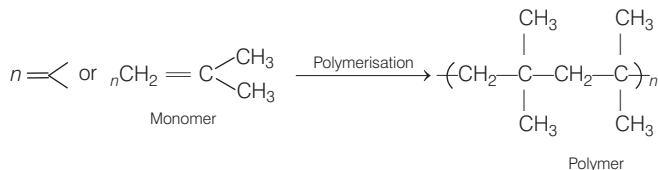

**Q. 8** Which of the following polymer can be formed by using the following monomer unit?

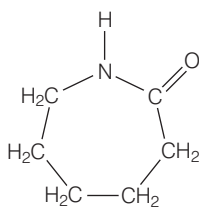

- (a) Nylon-6, 6 (b) Nylon-2-nylon-6  
(c) Melamine polymer (d) Nylon-6

**Ans. (d)** Given, monomer is the structure of caprolactum which on polymerisation produces Nylon-6.

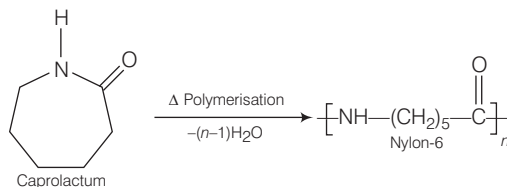

## Multiple Choice Questions (More Than One Options)

**Q. 9** Which of the following polymers, need atleast one diene monomer for their preparation?

- (a) Dacron (b) Buna-S  
(c) Neoprene (d) Novolac

**Ans. (b, c)**

Buna-S and neoprene are two such polymers which needs atleast one diene monomer for their preparation.

(b) Buna-S is prepared by copolymerisation of 1, 3-butadiene and styrene.

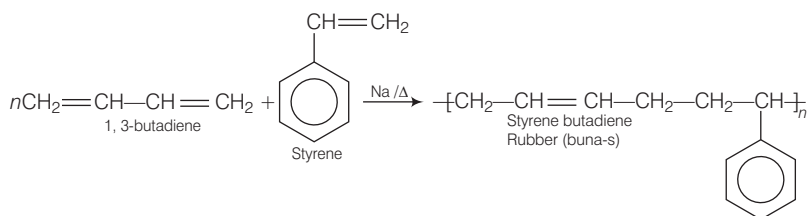

(c) Neoprene is prepared by polymerisation of chloroprene

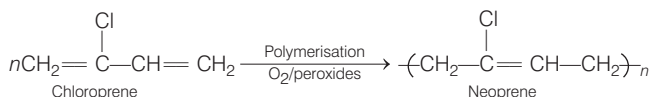

**Q. 10** Which of the following are characteristics of thermosetting polymers?

- (a) Heavily branched cross linked polymers  
(b) Linear slightly branched long chain molecules  
(c) Become infusible on moulding so cannot be reused  
(d) Soften on heating and harden on cooling, can be reused

**Ans. (a, c)**

**Thermosetting polymer**

- (i) These are cross linked or heavily branched molecule.  
(ii) These on heating undergo extensive cross linking in moulds and become infusible  
(iii) These cannot be reused.  
(iv) Examples are bakelite, urea-form aldehydesin.

**Q. 11** Which of the following polymers are thermoplastic?

- (a) Teflon (b) Natural rubber (c) Neoprene (d) Polystyrene

**Ans. (a, d)**

**Thermoplastic polymer**

- (i) These are linear or slightly branched long chain molecules.  
(ii) These polymers are hard at room temperature, become soft and viscous on heating and again rigid on cooling. This process of heat softening and hardening on cooling can be repeated as many times and as desired without any change in chemical composition.

**Q. 12** Which of the following polymers are used as fibre?

- (a) Polytetrafluoroethane (b) Polychloroprene  
(c) Nylon (d) Terylene

**Ans. (c, d)**

Nylon and terylene are used as fibre due to strong intermolecular forces like H-bonding which lead to close packing in chain and thus impart crystalline nature.

**Q. 13** Which of the following are addition polymers?

- (a) Nylon (b) Melamine formaldehyde resin  
(c) Orlon (d) Polystyrene

**Ans. (c, d)**

Addition polymers are formed by the repeated addition of a large number of same or different monomers possessing double and triple bonds.

e.g.,

- (i) Orlon is obtained by addition polymerisation of acrylonitrile in presence of a peroxide catalyst.

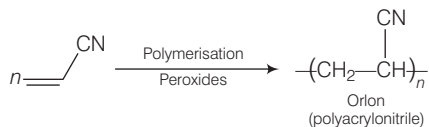

- (ii) Polystyrene is obtained by addition polymerisation of styrene.

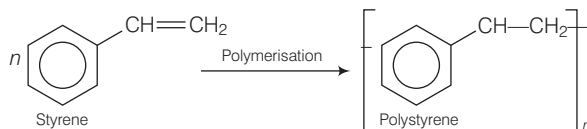

**Q. 14** Which of the following polymers are condensation polymers?

- (a) Bakelite  
(b) Teflon  
(c) Butyl rubber  
(d) Melamine formaldehyde resin

**Ans. (a, d)**

Condensation polymers are formed by repeated condensation reaction between two bifunctional or trifunctional monomer units usually with the elimination of small molecules like water, alcohol, ammonia,  $\text{CO}_2$ ,  $\text{HCl}$ .

e.g.,

- (i) Bakelite is obtained by polymerisation of phenol and formaldehyde.

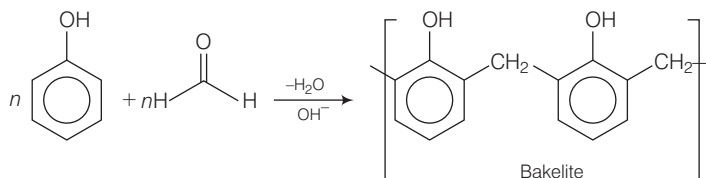

(ii) Melamine - Formaldehyde-resin

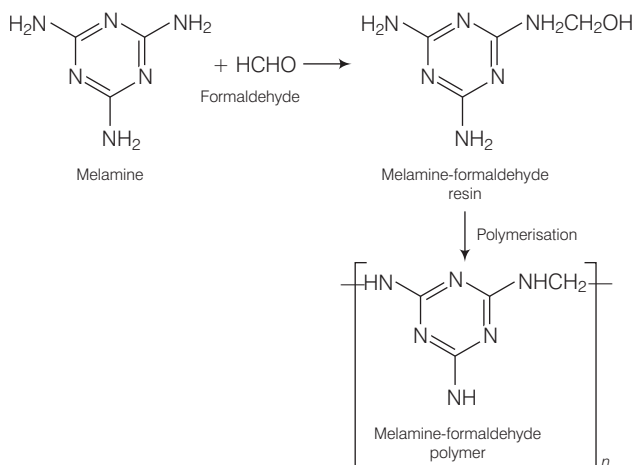
**Q. 15** Which of the following monomers form biodegradable polymers?

- (a) 3-hydroxybutanoic acid + 3-hydroxypentanoic acid  
 (b) Glycine + amino caproic acid  
 (c) Ethylene glycol + phthalic acid  
 (d) Caprolactam

**Ans. (a, b)**

**Biodegradable Polymer** The polymers which are easily decomposed and not harmful for the environment are known as biodegradable polymer.

e.g.,

- (i) PHBV is obtained by condensation polymerisation of 3 hydroxybutanoic acid and 3 hydroxypentanoic acid.

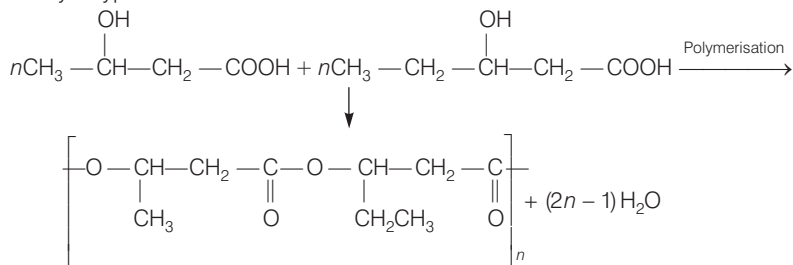

- (ii) Glycine and aminocaproic acid produces nylon-2 nylon-6 polymer.

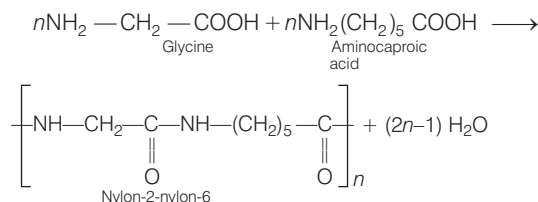

**Q. 16** Which of the following are example of synthetic rubber?

- (a) Polychloroprene (b) Polyacrylonitrile  
(c) Buna-N (d) *cis*-polyisoprene

**Ans. (a, c)**

**Synthetic Polymer** Polymer which are not found in nature and can be synthesised in laboratory and industry are known as synthetic polymer.

e.g.,

(i) Polychloroprene also known as neoprene is a polymer of chloroprene [monomer].

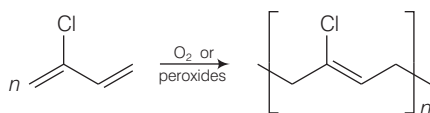

(ii) Buna-N can be obtained by copolymerisation of 1, 3-Butadiene and acrylonitrile as shown below

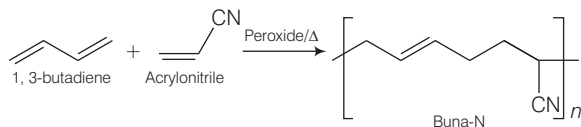

**Q. 17** Which of the following polymers can have strong intermolecular forces?

- (a) Nylon (b) Polystyrene (c) Rubber (d) Polyesters

**Ans. (a, d)**

Nylon and polyesters have strong intermolecular forces of attractions due to presence of ether H-bonding or dipole-dipole interactions.

**Q. 18** Which of the following polymers have vinylic monomer units?

- (a) Acrilan (b) Polystyrene (c) Nylon (d) Teflon

**Ans. (a, b, d)**

Acrilan, polystyrene and teflon has vinylic monomer units as shown below.

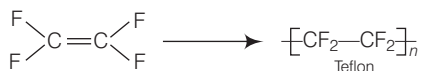
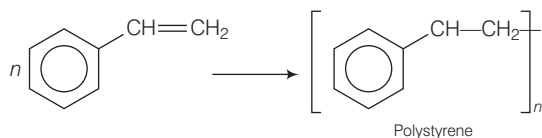
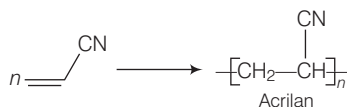



**Q. 19** Vulcanization makes rubber .....

- (a) more elastic (b) soluble in inorganic solvent  
(c) crystalline (d) more stiff

**Thinking Process**

This problem includes the concept of vulcanization of rubber and characteristic of vulcanized rubber. Vulcanization of rubber produces more elastic and more stiff rubber due to presence of sulphide linkage.

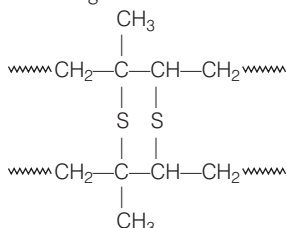

**Ans. (a, d)**

In vulcanized rubber, the polymer chains are held together by sulphur cross- linkages (—S—S—). These cross links make rubber more hard, elastic and stronger.

## Short Answer Type Questions

**Q. 20** A natural linear polymer of 2-methyl-1, 3-butadiene becomes hard on treatment with sulphur between 373 to 415 K and —S—S—bonds are formed between chains. Write the structure of the product of this treatment?

**Thinking Process**

This problem is based on vulcanized rubber and its structure.

**Ans.** The product is called vulcanised rubber. Its structure is

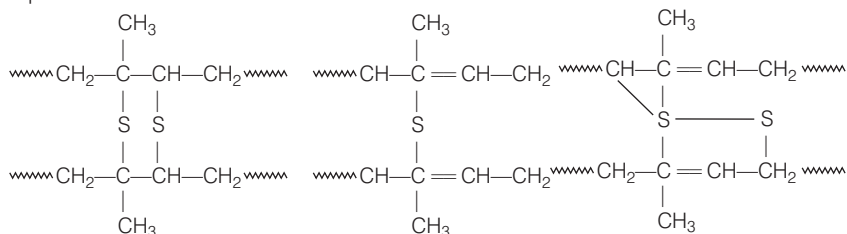

**Q. 21** Identify the type of polymer



**Ans.** Homopolymer as it contains only one type of monomer units. *i.e.*, only A monomer units.

**Q. 22** Identify the type of polymer



**Ans.** Copolymer, as it contains more than one type of monomer units. Here, A and B are two types of monomer units.

**Q. 23** Out of chain growth polymerisation and step growth polymerisation, in which type will you place the following.

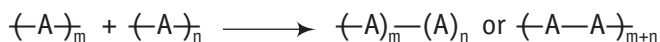

**Ans.** Chain growth polymerisation, as there is no loss of small molecules like water; methanol etc.



**Q. 24** Identify the type of polymer given in the following figure.

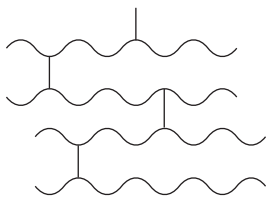

**Ans.** Cross-linked or network polymer.

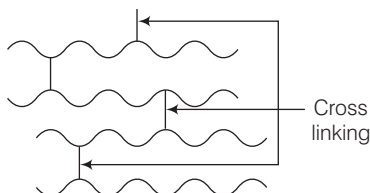

**Q. 25** Identify the polymer given below.

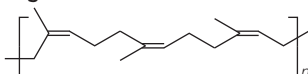

**Ans.** The given polymer is formed by 1, 4--addition of 2- methylbuta- 1,3- diene (isoprene) and stereochemistry is 'cis' throughout. Therefore, the given polymer is 'cis'- polyisoprene i.e., natural rubber.

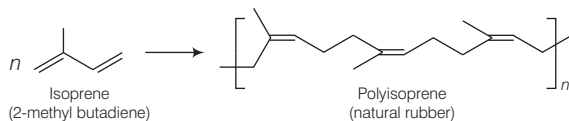

**Q. 26** Why are rubber called elastomers?

**Ans.** They change their shape on applying force and regain their original shape on removal of the applied force. Hence, rubbers are called elastomers.

**Q. 27** Can enzyme be called a polymer?

**Ans.** Yes, these are made up of proteins which are polymers of amino acids.

**Q. 28** Can nucleic acid, protein and starch be considered as step growth polymers?

**Ans.** Yes, nucleic acid, protein and starch can be considered as step growth polymers as during their polymerisation reaction, they lead to removal of water molecule or any neutral molecule also. Thus, these are the examples of condensation polymers or step growth polymerisation.

**Q. 29** How is the following resin intermediate prepared and which polymers is formed by this monomer unit?

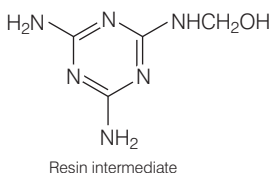

**Ans.** Reaction between melamine and formaldehyde can be shown as

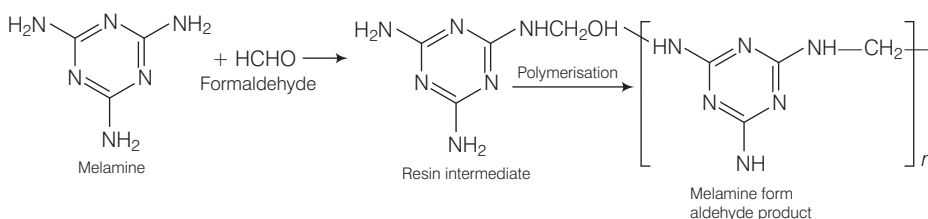

Melamine-formaldehyde polymer is formed by this monomer unit.

**Q. 30** To have practical applications why are cross links quetioined in rubber?

**Ans.** Cross links in rubber required for increasing the elasticity of rubber.

**Q. 31** Why does cis-polyisoprene posses elastic property?

**Ans.** *cis*-polyisoprene is also known as natural rubber. Its elastic property is due to the existence of weak van der Waals' interactions between their various polymer chains.

**Q. 32** What is the structural difference between HDP and LDP? How does the structure account for different behaviour and nature, hence use of a polymer?

**Ans.** HDP (high density polymer) consists of linear molecule and has a high density due to close packing. It is a translucent polymer. While LDP (low density polymer) has highly branched structure and hence, does not pack well resulting in low density. It is a transparent material.

**Q. 33** What is the role of benzoyl peroxide in addition polymerisation of alkenes? Explain its mode of action with the help of an example.

**Ans.** Role of benzoyl peroxide is to initiate the free radical polymerization reaction which can be easily understood by taking an example of polymerization of ethene to polyethene.

(i) Chain initiation

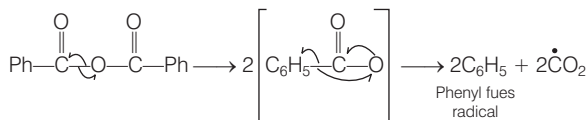

(ii) Chain propagation

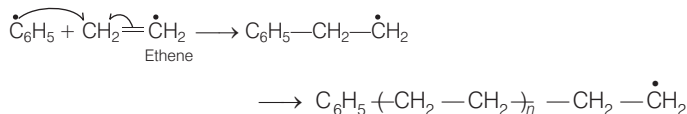

(iii) Chain terminator step

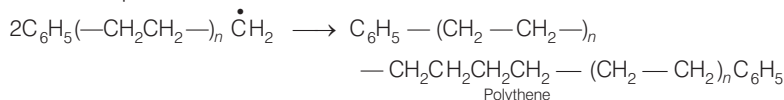

**Q. 34** Which factor imparts crystalline nature to a polymer like nylon?

**Ans.** Strong intermolecular forces like hydrogen bonding and linear structure that lead to close packing of chains and hence, imparts crystalline character. e.g., nylon

**Q. 35** Name the polymer used in laminating sheets and give the name of monomeric units involved in its formation.

**Ans.** Urea formaldehyde resin is used for laminated sheets. The monomer of this resin is urea ( $\text{NH}_2\text{CO}\text{NH}_2$ ) and formaldehyde ( $\text{HCHO}$ )

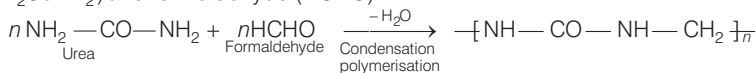

**Q. 36** Which type of biomolecules have some structural similarity with synthetic polyamides? What is similarity?

**Ans.** Polyamides have structural repetition of amide linkages which is similar to peptide bond as present in polypeptide chains of proteins.

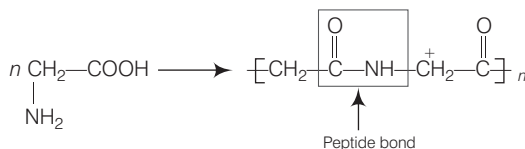

**Q. 37** Why should the monomer used in addition polymerisation through free radical pathway be very pure?

**Ans.** During free radical polymerisation, monomers should be very pure because even very trace amounts of impurities may act as inhibitors which leads to the formation of polymers with shorter length.

## Matching The Columns

**Q. 38** Match the polymer of Column I with correct monomer of Column II.

Column I	Column II
A. High density polyethene	1. Isoprene
B. Neoprene	2. Tetrafluoro ethene
C. Natural rubber	3. Chloroprene
D. Teflon	4. Acrylonitrile
E. Acrilan	5. Ethene

**Ans.** A. → (5)   B. → (3)   C. → (1)   D. → (2)   E. → (4)

Column I represents various kind of polymer and Column II represents their monomer units. Correct matching can be done as

Column I	Column II
A. High density polymer	Ethene
B. Neoprene	Chloroprene
C. Natural rubber	Isoprene
D. Teflon	Tetrafluoroethene
E. Acrilan	Acrylonitrile

**Q. 39** Match the polymers given in Column I with their chemical names given in Column II.

Column I	Column II
A. Nylon-6	1. Polyvinyl chloride
B. PVC	2. Polyacrylonitrile
C. Acrilan	3. Polycaprolactum
D. Natural rubber	4. Low density polythene
E. LDP	5. <i>cis</i> -polyisoprene

**Ans.** A. → (3)   B. → (1)   C. → (2)   D. → (5)   E. → (4)

Column I represents various polymers and Column II represents their chemical names.

Column I	Column II
A. Nylon-6	Polycaprolactum
B. PVC	Polyvinyl chloride
C. Acrilan	Polyacrylonitrile
D. Natural rubber	<i>cis</i> -polyisoprene
E. LDP	Low density polythene

**Q. 40** Match the polymers given in Column I with their commercial names given in Column II.

Column I	Column II
A. Polyester of glycol and phthalic acid	1. Novolac
B. Copolymer of 1, 3-butadiene and styrene	2. Glyptal
C. Phenol and formaldehyde resin	3. Buna-S
D. Polyester of glycol and terephthalic acid	4. Buna-N
E. Copolymer of 1,3- butadiene and acrylonitrile	5. Dacron

**Ans.** A. → (2) B. → (3) C. → (1) D. → (5) E. → (4)

Column I represents monomers of polymer and Column II represents their commercial name.

Column I	Column II
A. Polyester of glycol and phthalic acid	Glyptal
B. Copolymer of 1, 3-butadiene and styrene	Buna-S
C. Phenol and formaldehyde resin	Novolac
D. Polyester of glycol and terephthalic acid	Dacron
E. Copolymer of 1, 3-butadiene and acrylonitrile	Buna-N

**Q. 41** Match the polymers given in Column I with their main applications given in Column II.

Column I	Column II
A. Bakelite	1. Unbreakable crockery
B. Low density polyethene	2. Non-stick cookwares
C. Melamine-formaldehyde resin	3. Packaging material for shock absorbance
D. Nylon-6	4. Electrical switches
E. Polytetrafluoroethane	5. Squeeze bottles
F. Polystyrene	6. Tyre, cords

**Ans.** A. → (4) B. → (5) C. → (1) D. → (6) E. → (4) F. → (3)

Column I	Column II
A. Bakelite	Electrical switches
B. Low density polyethene	Squeeze bottles
C. Melamine-formaldehyde resin	Unbreakable crockery
D. Nylon-6	Tyre, cords
E. Polytetrafluoroethane	Non-stick cookwares
F. Polystyrene	Packaging material for shock absorbance

**Q. 42** Match the polymers given in Column I with the preferred mode of polymerisation followed by their monomers Column II.

Column I	Column II
A. Nylon-6,6	1. Free radical polymerisation
B. PVC	2. Ziegler-Natta polymerisation or coordination polymerisation
C. HDP	3. Anionic polymerisation
	4. Condensation polymerisation

**Ans.** A. → (4) B. → (1) C. → (2)

Column I represents name of various polymer and Column II represents mechanism of polymerisation. Correct matching can be done as

Column I (Polymer)	Column II (Mechanism of polymerisation)
A. Nylon-6,6	Condensation polymerisation
B. PVC	Free radical polymerisation
C. HDP	Ziegler-Natta polymerisation or coordination polymerisation

**Q. 43** Match the polymers given in Column I with the type of linkage present in them given in Column II.

Column I	Column II
A. Terylene	1. Glycosidic linkage
B. Nylon	2. Ester linkage
C. Cellulose	3. Phosphodiester linkage
D. Protein	4. Amide linkage
E. RNA	

**Ans.** A. → (2) B. → (4) C. → (1) D. → (4) E. → (3)

Column I represents name of polymer and Column II represents types of linkage. Hence, correct matching can be done as

Column I	Column II
A. Terylene	Ester linkage
B. Nylon	Amide linkage
C. Cellulose	Glycosidic linkage
D. Protein	Amide linkage
E. RNA	Phosphodiester linkage

**Q. 44** Match materials given in Column I with the polymers given in Column II.

Column I	Column II
A. Natural rubber latex	1. Nylon
B. Wood laminates	2. Neoprene
C. Ropes and fibres	3. Dacron
D. Polyester fabric	4. Melamine formaldehyde resins
E. Synthetic rubber	5. Urea-formaldehyde resins
F. Unbreakable crockery	6. <i>cis</i> -polyisoprene

**Ans.** A. → (6) B. → (5) C. → (1) D. → (3) E. → (2) F. → (4)

Column I represents various uses or precursors of polymers and Column II represents name of related polymer. The correct matching can be done as

Column I	Column II
A. Natural rubber latex	<i>cis</i> -polyisoprene
B. Wood laminates	Urea-formaldehyde resins
C. Ropes and fibres	Nylon
D. Polyester fabric	Dacron
E. Synthetic rubber	Neoprene
F. Unbreakable crockery	Melamine formaldehyde resins

**Q. 45** Match the polymers given in Column I with their repeating units given in Column II.

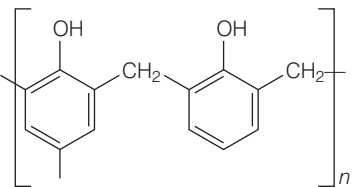
Column I	Column II
A. Acrilan	1. $\left[ \text{CH}_2 - \underset{\text{C}_6\text{H}_5}{\text{CH}} \right]_n$
B. Polystyrene	2. $\left[ \text{CH}_2 - \underset{\text{Cl}}{\text{C}} = \text{CH} - \text{CH}_2 \right]_n$
C. Neoprene	3. $\left[ \text{CH}_2 - \text{CH} = \text{CH} - \text{CH}_2 - \underset{\text{Cl}}{\text{CH}_2} - \text{CH} \right]_n$
D. Novolac	4. $\left[ \text{CH}_2 - \underset{\text{CN}}{\text{CH}} \right]_n$
E. Buna-N	5. 
	6. $\left[ \text{CH}_2 - \underset{\text{Cl}}{\text{CH}} \right]_n$



**Ans. A.** → (4)    **B.** → (1)    **C.** → (2)    **D.** → (4)    **E.** → (3)

Column I represents name of polymer and Column II represents their molecular formula. The correct matching can be done as

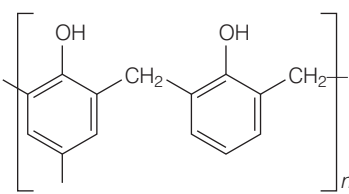
Column I	Column II
A. Acrilan	$\left[ \text{CH}_2 - \underset{\text{CN}}{\text{CH}} \right]_n$
B. Polystyrene	$\left[ \text{CH}_2 - \underset{\text{C}_6\text{H}_5}{\text{CH}} \right]_n$
C. Neoprene	$\left[ \text{CH}_2 - \underset{\text{Cl}}{\text{C}} = \text{CH} - \text{CH}_2 \right]_n$
D. Novolac	
E. Buna-N	$\left[ \text{CH}_2 - \text{CH} = \text{CH} - \text{CH}_2 - \underset{\text{Cl}}{\text{CH}_2} - \text{CH} \right]_n$

## Assertion and Reason

*In the following questions a statement of assertion (A) followed by a statement of reason (R) is given. Choose the correct answer out of the following choices.*

- Assertion and Reason both are correct statement But reason does not explain Assertion.
- Assertion and Reason both are correct statements and Reason explains the Assertion.
- Both assertion and reason are wrong statements.
- Assertion is correct statement and Reason is wrong statement.
- Assertion is wrong statement and reason is correct statement.

**Q. 46 Assertion (A)** Rayon is a semisynthetic polymer and is taken as a better choice than cotton fabric.

**Reason (R)** Mechanical and aesthetic properties of cellulose can be improved by Acetylation.

**Ans. (b)** Assertion and reason both are correct and reason explains the assertion.

Rayon is a semisynthetic polymer and is taken as a better choice than cotton fabric because mechanical and aesthetic properties of cellulose can be improved by acetylation.

**Q. 47 Assertion (A)** Most of the synthetic polymers are not biodegradable.

**Reason (R)** Polymerisation process induces toxic character in organic molecules.

**Ans. (d)** Assertion is correct statement but reason is not correct statement. Most of synthetic polymers are not biodegradable because they are not easily broken by soil organisms and hazardous to the environment.

**Q. 48 Assertion (A)** Olefinic monomers undergo addition polymerisation.

**Reason (R)** Polymerisation of vinyl chloride is initiated by peroxides/persulphates.

**Ans. (a)** Assertion and reason both are correct but reason does not explain assertion.

Olefin monomers undergo addition polymerisation because it add on to other monomers of olefin through free radical mechanism due to the presence of peroxide initiator and double bond and produces high molecular mass polymers.

**Q. 49 Assertion (A)** Polyamides are best used as fibres because of high tensile strength.

**Reason (R)** Strong intermolecular forces (like hydrogen bonding within polyamides) lead to close packing of chains and increase the crystalline character, hence, provide high tensile strength to polymers.

**Ans. (b)** Assertion and reason both are correct and reason explains assertion. Polyamides are best used as fibres because of high tensile strength. This is due to strong intermolecular forces (like hydrogen bonding within polyamides) lead to close packing of chains and increase the crystalline character, hence, provide high tensile strength to polymers.

**Q. 50 Assertion (A)** For making rubber synthetically, isoprene molecules are polymerised.

**Reason (R)** Neoprene (a polymer of chloroprene) is a synthetic rubber.

**Ans. (e)** Assertion is wrong and reason is correct statement. Correct assertion is, neoprene is a naturally occurring polymer of chloroprene prepared by polymerisation of 2-chloro butadiene.

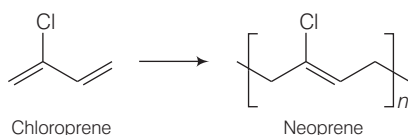

**Q. 51 Assertion (A)** Network polymers are thermosetting.

**Reason (R)** Network polymers have high molecular mass.

**Ans. (a)** Assertion and reason both are correct and reason does not explain assertion.

Network polymers are thermosetting because they can't be reused after heating once. Because after heating it undergo extensive cross linking in moulds and again become infusible.

**Q. 52 Assertion (A)** Polytetrafluoroethene is used in making non-stick cookwares.

**Reason (R)** Fluorine has highest electronegativity.

**Ans. (a)** Assertion and reason both are correct but reason does not explain assertion.

Polytetrafluoroethene (teflon) is used in making non-stick cookwares because it is chemically inert, thermally stable and resistant to attack by corrosive reagents.

## Long Answer Type Questions

**Q. 53** Synthetic polymers do not degrade in the environment for a long time. How can biodegradable synthetic polymers be made. Differentiate between biopolymers and biodegradable polymers and give examples of each type.

**Ans.** Synthetic polymers are quite resistant to environmental degradation process and are responsible for accumulation of polymer solid waste material. New biodegradable synthetic polymers have been designed and developed. These polymers contain similar functional groups as present in biopolymers.

e.g., aliphatic polyesters

Biopolymer, are polymers of amino acid or carbohydrates which are linked to each other by peptide or glycosidic linkages as shown below

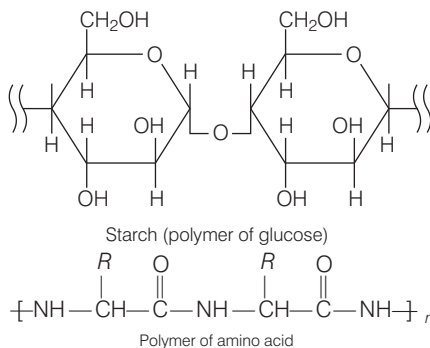

Biopolymer can or can't be biodegradable.

e.g., protein, starch etc, are biodegradable but keratin are non-biodegradable.

Biodegradable polymer are polymers which can be degraded always.

e.g., DHBV nylon-2, Nylon-6

**Q. 54** Differentiate between rubbers and plastics on the basis of intermolecular forces.

**Ans.** Rubber is a natural polymer which possess elastic properties. Natural polymer is a linear polymer of isoprene (2-methyl-1, 3-butadiene).

In natural rubber *cis*-polyisoprene molecules consists of various chains held together by weak van der Waals' interaction and has coiling structure. So, it can be stretched like a spring.

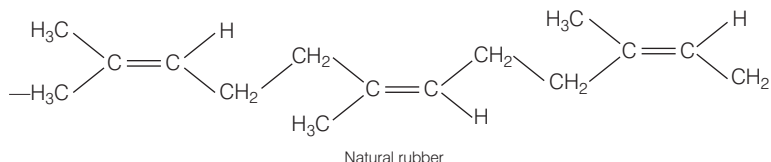

Plastics are generally polymer of ethene known as polythene. Polythene is thermoplastic polymer which may be linear (HDP) or branched (LDP) these type of polymers. Possesses intermediate intermolecular forces of attraction. It has linear, structure that can be moulded but can't be regained on its original shape after stretching.

**Q. 55** Phenol and formaldehyde undergo condensation to give a polymer (A) which on heating with formaldehyde gives a thermosetting polymer (B). Name the polymers. Write the reactions involved in the formation of (A). What is the structural difference between two polymers?

**Ans.** Phenol and formaldehyde undergo condensation to give a polymer novolac (A) which on heating with formaldehyde gives bakelite (B) as a thermosetting polymer. Sequence of the reaction can be written as

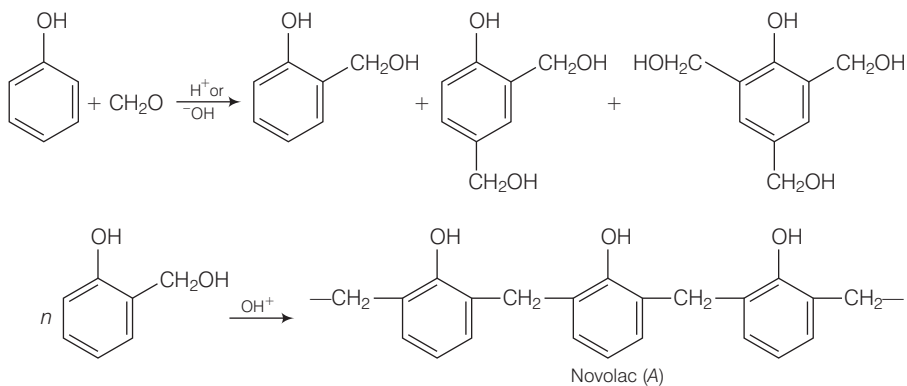

Structural difference in between these two is that novolac is a linear polymer while bakelite is a cross linked polymer.

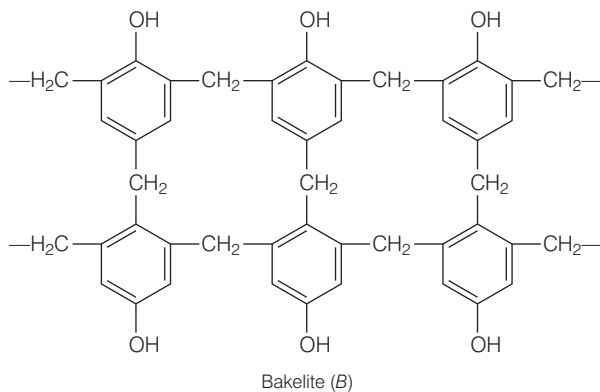

**Q. 56** Low density polythene and high density polythene, both are polymers of ethene but there is marked difference in their properties. Explain.

**Ans.** Low density and high density polythenes are obtained under different conditions. These differ in their structural features. Low density polythenes are highly branched structures while high density polythene consists of closely packed linear molecules. Close packing increases the density.

**Q. 57** Which of the following polymers soften on heating and harden on cooling? What are the polymers with this property collectively called? What are the structural similarities between such polymers? Bakelite, urea-formaldehyde resin, polythene, polyvinyls, polystyrene.

**Ans.** Polythene, polyvinyls and polystyrene soften on heating and harden on cooling. Such polymers are called thermoplastic polymers. These polymers are linear array of slightly branched long chain molecules.

These possess intermolecular forces whose strength lies between strength of intermolecular forces of elastomers and fibres while bakelite, urea formaldehyde resin are thermosetting polymers which on heating undergo extensive cross linking in moulds and again become infusible.

# 16

## Chemistry Everyday Life

### Multiple Choice Questions (MCQs)

**Q. 1** Which of the following statements is not correct?

- (a) Some antiseptics can be added to soaps
- (b) Dilute solutions of some disinfectants can be used as antiseptic
- (c) Disinfectants are antimicrobial drugs
- (d) Antiseptic medicines can be ingested

**Ans.(d)** An antiseptic is an antimicrobial drug. It tends to destroy/prevent development or inhibit the pathogenic action of microbes. Antiseptics are applied to the living tissues such as wounds, cuts, ulcers and diseased skin surfaces *e.g.*, soframincine.

Bithionol the compound is also called bithional is added to soaps to impart antiseptic properties.

Dilute solutions of some disinfectants can be used as antiseptic *e.g.*, 0.2 per cent solution of phenol is an antiseptic while its one per cent solution is disinfectant. But, antiseptic medicines can not be ingested like antibiotics.

**Q. 2** Which is the correct statement about birth control pills?

- (a) Contain estrogen only
- (b) Contain progesterone only
- (c) Contain a mixture of estrogen and progesterone derivatives
- (d) Progesterone enhances ovulation

**Ans.(c)** Chemical substances which are used to check pregnancy in women are called birth control pills. Birth control pills essentially contain a mixture of synthetic estrogen and progesterone derivatives, both of these are sex hormones. It is known that progesterone suppresses ovulation and estrogen control the menstrual cycle.

Some of the commonly used pills contain a mixture of norethindrone (a progesterone derivative) and novestrol (an estrogen).



**Q. 5** Which of the following statements is correct?

- (a) Some tranquilizers function by inhibiting the enzymes which catalyse the degradation of noradrenaline
- (b) Tranquilizers are narcotic drugs
- (c) Tranquilizers are chemical compounds that do not affect the message transfer from nerve to receptor
- (d) Tranquilizers are chemical compounds that can relieve pain and fever

**Ans. (a)** Tranquilizers are used for the treatment of stress, fatigue, mild and severe mental diseases. They relieve anxiety, stress, irritability or excitement by inducing a sense of well-being. Noradrenaline is one of the several neurotransmitters which play an important role in mood changes.

If the level of noradrenaline in the body is low for some reasons, then the message transfer process becomes slow and the person suffer from depression. In such cases, antidepressant drugs are used. These drugs inhibits the enzymes which catalyse the degradation of noradrenaline.

If the enzyme is inhibited, then the neurotransmitter noradrenaline is slowly metabolised and can thus activate the receptor for longer periods there by counteracting the effect of depression. Tranquilizers form an essential component of sleeping pills.

**Q. 6** Salvarsan is arsenic containing drug which was first used for the treatment of .....

- (a) syphilis
- (b) typhoid
- (c) meningitis
- (d) dysentery

**Ans. (a)** Syphilis is an acute and chronic infections disease caused by the bacterium *Treponema pallidum*. It is a sexually transmitted infection. The primary route of transmission is through sexual contact but it may also be transmitted from mother to foetus during pregnancy or at birth.

Paul Ehrlich investigated arsenic based structures in order to produce less toxic substances for the treatment of syphilis as he got Nobel prize for medicine in 1908 for this discovery. Salvarsan was the first effective medicine discovered for syphilis. Although salvarsan is toxic to human beings, its effect on bacteria is much greater than on human being. Structure of salvarsan is –

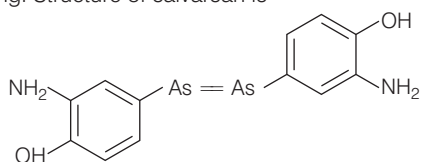

**Q. 7** A narrow spectrum antibiotic is active against .....

- (a) gram positive or gram negative bacteria
- (b) gram negative bacteria only
- (c) single organism or one disease
- (d) both gram positive and gram negative bacteria

**Ans. (a)** Antibiotics are now defined as chemical substances which in low concentration, either kill or inhibit the growth of microorganisms by intervening in their metabolic processes. The full range of microorganisms attacked by an antibiotic is called its spectrum.

Broad spectrum antibiotics are effective against several different types of harmful bacteria *i.e.*, a wide range of gram-positive and gram-negative bacteria. These effective mainly against gram-positive or gram-negative bacteria are narrow spectrum antibiotics. Chloramphenicol is a broad spectrum antibiotic penicillin-G has a narrow spectrum. If an antibiotic is effective against a single organism or disease then it is limited spectrum antibiotic.



**Q. 8** The compound that causes general antirepressant action on the central nervous system belongs to the class of.....

- (a) analgesics (b) tranquilizers  
(c) narcotic analgesics (d) antihistamines

**Ans. (b)** Analgesics reduces or abolish pain without causing impairment of consciousness, mental confusion, incoordination or paralysis or some other disturbances of nervous system. Analgesics are non-narcotic or narcotic. Narcotic analgesics when administered in small doses relieve pain and produce sleep.

Tranquilisers are a class of chemical compounds used for the treatment of stress, and mild or even severe mental diseases.

Histamine is a substance which on release produce hypersensitivity to dust, some drugs etc (*i.e.*, allergy). Antihistamines are the drugs which interfere with the natural action of histamine by competing with histamine for binding sites of receptor where histamine exerts its effect. They are anti-allergy drugs.

**Q. 9** Compound which is added to soap to impart antiseptic properties is .....

- (a) sodium laurylsulphate (b) sodium dodecylbenzenesulphonate  
(c) rosin (d) bithional

**Ans. (d)** Basically, all soaps are made by boiling fats or oils with suitable hydroxide. Variations are made by adding different raw materials. Sodium laurylsulphate and sodium dodecylbenzenesulphonate are anionic detergents.

A gum rosin added to soap to make it lather well. Bithional is added to soaps to impart antiseptic properties to soap.

**Q. 10** Equanil is .....

- (a) artificial sweetener (b) tranquilizer  
(c) antihistamine (d) antifertility drug

**Ans. (b)** Equanil is a tranquilizer.

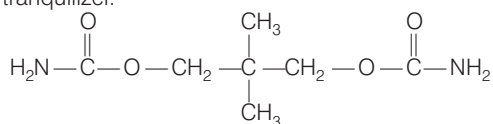

Structure of equanil

(Also, refer to Q. 5)

**Q. 11** Which of the following enhances leathering property of soap?

- (a) Sodium carbonate (b) Sodium rosinate  
(c) Sodium stearate (d) Trisodium phosphate

**Ans. (b)** Shaving soaps contain glycerol to prevent rapid drying. While preparing this soaps, a gum called rosin is added to them. It forms sodium rosinate which lathers well. Laundry soaps contain fillers like sodium rosinate, sodium silicate, borax and sodium carbonate.

Trisodium polyphosphate is an important filler added to detergent powders and liquid detergents.

**Q. 12** Glycerol is added to soap. It functions .....

- (a) as a filler (b) to increase leathering  
(c) to prevent rapid drying (d) to make soap granules

**Ans. (c)** Glycerol is added to shaving soap to prevent rapid drying while to enhance the leathering property of soap, a gum called rosin is added to them. It forms sodium rosinate which lathers well. Soap granules are dried miniature soap bubbles. Builders/fillers make the soap act more rapidly. Builder or filler (e.g. sodium tripolyphosphate) is added to detergent powder. Its main function is to act as water softener by removing  $Mg^{2+}$  and  $Ca^{2+}$  ions from hard water by forming stable soluble complexes.

**Q. 13** Which of the following is an example of liquid dishwashing detergent?

- (a)  $CH_3(CH_2)_{10} - CH_2OSO_3^- Na^+$   
 (b)  $C_9H_{19} - \text{C}_6\text{H}_4 - O - (CH_2 - CH_2 - O)_5 - CH_2CH_2OH$   
 (c)  $CH_3 - \text{C}_6\text{H}_4 - SO_3^- Na^+$   
 (d)  $\left[ CH_3(CH_2)_{15} - \overset{\overset{CH_3}{|}}{N} - CH_3 \right]^+ Br^-$

**Ans. (b)** Liquid dishwashing detergents are non-ionic type. Non-ionic detergents do not contain any ion in their constitution. Mechanism of cleansing action of this type of soaps. These remove grease and oil by micelle formation.

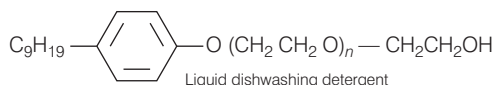

Other two classes of detergents are anionic detergents and cationic detergents. Anionic detergents are sodium salts of sulphonated long chain alcohols or hydrocarbons.

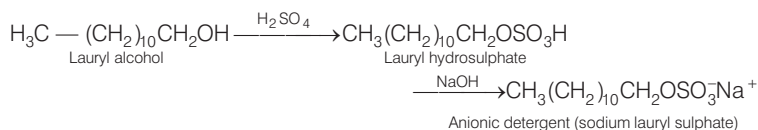

They are mostly used for household work.

Cationic detergents are quaternary ammonium salts of amines with acetates, chlorides or bromides as anions. Cetyltrimethylammonium bromide is a popular cationic detergent and is used in hair conditioners.

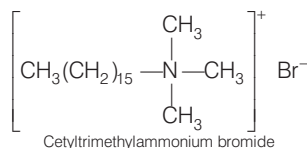

**Q. 14** Polyethyleneglycols are used in the preparation of which type of detergents?

- (a) Cationic detergents (b) Anionic detergents  
(c) Non-ionic detergents (d) Soaps

**Ans. (c)** Polyethyleneglycols are used in the preparation of non-ionic detergents. Non-ionic detergents do not contain any ion in their constitution.

Reaction is as follow

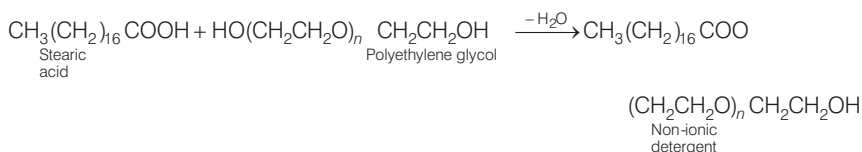

**Q. 15** Which of the following is not a target molecule for drug function in body?

- (a) Carbohydrates (b) Lipids (c) Vitamins (d) Proteins

**Ans. (c)** Drugs usually interact with biomolecules such as carbohydrates, lipids, proteins and nucleic acids. These are called drug targets. Vitamins are not a target molecule for drug function in body.

**Q. 16** Which of the following statements is not true about enzyme inhibitors?

- (a) Inhibit the catalytic activity of the enzyme  
(b) Prevent the binding of substrate  
(c) Generally a strong covalent bond is formed between an inhibitor and an enzyme  
(d) Inhibitors can be competitive or non-competitive

**Ans. (c)** Drugs can block the binding site of the enzyme and prevent the binding of substrate, or can inhibit the catalytic activity of the enzyme. Such drugs are called enzyme inhibitors. Drugs inhibit the attachment of substrate on active site of enzyme in two different ways.

- (i) Drugs which compete with natural substrate for their attachment on the active sites of enzymes are called competitive inhibitors.

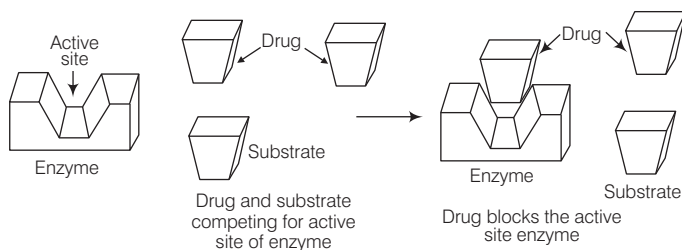

**Competitive inhibitors (Drug and substrate competing for active site)**

- (ii) However, some drugs do not bind to the active site but bind to a different site of enzyme *i.e.*, allosteric site which changes the shape of the active site of the enzyme in such a way that the natural substrate cannot recognize it. Such enzymes are called non-competitive inhibitors.

Generally, a weak bond such as hydrogen bonding, van der Waals' interactions etc., is formed between the enzyme and inhibitor.

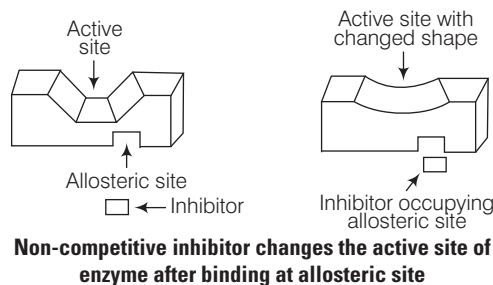

**Q. 17** Which of the following chemicals can be added for sweetening of food items at cooking temperature and does not provide calories?

- (a) Sucrose (b) Glucose  
(c) Aspartame (d) Sucralose

**Ans. (d)** Sucrose and glucose are natural sweetening agent while aspartame and sucralose are artificial sweetening agent.

Aspartame is roughly 100 times as sweet as cane sugar. It is methyl ester of dipeptide formed from aspartic acid and phenylalanine. Use of aspartame is limited to cold foods and soft drinks because it is unstable at cooking temperature.

Sucralose is trichloro derivative of sucrose. Its appearance and taste are like sugar. It is stable at cooking temperature. It does not provide calories.

**Q. 18** Which of the following will not enhance nutritional value of food?

- (a) Minerals (b) Artificial sweeteners  
(c) Vitamins (d) Amino acids

**Ans. (b)** Vitamins and minerals are essential nutrients because they perform hundred of roles in the body. They help shore up bones, heal wounds, and bolster immune system. They also convert food into energy, and repair cellular damage.

Artificial sweeteners are non-caloric substitutes for sugar. They are often intensely more sweet than sugar but do not enhance nutritional value of food.

Amino acids are the monomers of proteins. Proteins require for the growth and maintenance of the body. Therefore, amino acids will also enhance the nutritional value of food.

## Multiple Choice Questions (More Than One Options)

**Q. 19** Which of the following statements are incorrect about receptor proteins?

- (a) Majority of receptor proteins are embedded in the cell membranes
- (b) The active site of receptor proteins opens on the inside region of the cell
- (c) Chemical messengers are received at the binding sites of receptor proteins
- (d) Shape of receptor doesn't change during attachment of messenger

**Ans. (b, d)**

Receptors are proteins that are crucial to body's communication process. Majority of these are embedded in cell membranes. They are embedded in the cell membrane in such a way that their small part possessing active site projects out of the surface of the membrane and opens on the outside region of the cell membrane.

In the body, message between two neurons and that between neuron to muscles is communicated through certain chemicals. These chemicals, known as chemical messengers are received at the binding site of receptors proteins.

To accommodate a messenger, shape of the receptor site changes. This brings about the transfer of message into the cell. Thus, chemical messenger gives message to the cell without entering the cell.

**Q. 20** Which of the following are not used as food preservatives?

- (a) Table salt
- (b) Sodium hydrogencarbonate
- (c) Cane sugar
- (d) Benzoic acid

**Ans. (b, c)**

Food preservatives prevent spoilage of food due to microbial growth. The most commonly used preservatives include table salt, sugar, vegetable oils and sodium benzoate. Sodium hydrogen carbonate and cane sugar are not used as food preservatives.

**Q. 21** Compounds with antiseptic properties are .....

- (a)  $\text{CHCl}_3$
- (b)  $\text{CHI}_3$
- (c) boric acid
- (d) 0.3 ppm aqueous solution of  $\text{Cl}_2$

**Ans. (b, c)**

Antiseptics are the chemical substances which either kill or prevent the growth of microorganisms.

- (a)  $\text{CHCl}_3$  (chloroform) was used as an anaesthesia in surgery but now it is used in the production of the freon refrigerant R-22.
- (b) Iodoform ( $\text{CHI}_3$ ) produces iodine on coming in contact with skin, so it is used as an antiseptic for wounds.
- (c) Boric acid ( $\text{H}_3\text{BO}_3$ ) in dilute aqueous solution is a weak antiseptic for eyes. Thus, chemical messenger gives message to the all without entering the cell.
- (d) Chlorine in the concentration of 0.2 to 0.4 ppm in aqueous solution and sulphur dioxide in very low concentrations, are disinfectants.

**Q. 22** Which of the following statements are correct about barbiturates?

- (a) Hypnotics or sleep producing agents
- (b) These are tranquilizers
- (c) Non-narcotic analgesics
- (d) Pain reducing without disturbing the nervous system

**Ans. (a, b)**

Barbituric acid and its derivatives such as veronal, luminal, seconal, amytal and nembital constitute an important class of tranquilizers called barbiturates. They are used as hypnotics *i.e.*, sleep producing agents.

**Q. 23** Which of the following are sulpha drugs?

- (a) Sulphapyridine (b) Prontosil  
(c) Salvarsan (d) Nardil

**Ans. (a, b)**

Sulpha drugs kills bacteria and fungi by interfering with their metabolism.

- (a) Sulphapyridine is a sulphonamide antibacterial drug. It is no longer prescribed for the treatment of infections in humans. It is a good antibacterial drug, but its water solubility is very pH dependent. Thus, there is a risk of crystallisation within the bladder or urethra, which could lead to pain or blockage.
- (b) Prontosil is also called sulphamidochrysoidine. It is used in the treatment of general bacterial infection in humans.
- (c) Salvarsan is arsenic based antibacterial drug. It is used in the treatment of syphilis.
- (d) Nardil is an antidepressant drug.

**Q. 24** Which of the following are antidepressants?

- (a) Iproniazid (b) Phenelzine  
(c) Equanil (d) Salvarsan

**Ans. (a, b, c)**

Antidepressants are the substances which correct chemical imbalances of neurotransmitters in the brain and probably cause changes in mood and behaviour.

Iproniazid is a hydrazine drug used as an antidepressant. Phenelzine is also known as Nardil. It is used in the treatment of major depressive disorder. Equanil is used in controlling depression and hypertension.

Salvarsan is an antibacterial drug. It is used in the treatment of Syphilis.

**Q. 25** Which of the following statements are incorrect about penicillin?

- (a) An antibacterial fungus  
(b) Ampicillin is its synthetic modification  
(c) It has bacteriostatic effect  
(d) It is a broad spectrum antibiotic

**Ans. (c, d)**

Penicillin is a group of antibiotics derived from *Penicillium* fungi. Ampicillin and Amoxycillin are synthetic modifications of penicillin. Penicillin destroys bacteria by destroying the cell wall of the microorganism or kill the bacteria so, it has bacteriocidal effect.

Penicillin as a class of antibiotics are generally narrow spectrum but when used in the combination with other antibiotics, it can make up a part of broad spectrum antibiotics.

**Q. 26** Which of the following compounds are administered as antacids?

- (a) Sodium carbonate (b) Sodium hydrogencarbonate  
(c) Aluminium carbonate (d) Magnesium hydroxide

**Ans. (b, d)**

Antacid is a substance which neutralizes excess of acid in stomach. The chemical formula of sodium hydrogen carbonate is  $\text{NaHCO}_3$ . It is often used as an antacid because it neutralises excess of HCl secreted from the walls of stomach

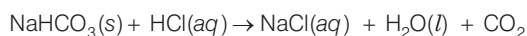

However, excessive hydrogen carbonate can make the stomach alkaline and trigger the production of even more acid.

Milk of magnesia, which is an aqueous solution of magnesium hydroxide is also used as an antacid.

**Q. 27** Amongst the following antihistamines, which are antacids?

- |                 |                     |
|-----------------|---------------------|
| (a) Ranitidine  | (b) Brompheniramine |
| (c) Terfenadine | (d) Cimetidine      |

**💡 Thinking Process**

*This question is based on the inter-relation between the antihistamines and antacids. Antihistaminic drugs are used in the treatment of hyperacidity came through the discovery according to which a chemical, histamine, stimulates the secretion of pepsin and hydrochloric acid in the stomach.*

**Ans. (a, d)**

Histamine is a substance that stimulates the secretion of pepsin and hydrochloric acid. There are some antacids like cimetidine were designed to prevent the interaction of histamine with the receptors present in the stomach wall. As a result less HCl is released and the cause of hyperacidity is controlled/cured.

Ranitidine is also fall in the category of antihistamine. It is used to cure hyperacidity.

Brompheniramine is an antihistamine. It is used to treat runny nose, sneezing, itching and watery eyes caused by allergy.

Terfenadine, an antihistamine, was used for allergy.

**Q. 28** Veronal and luminal are derivatives of barbituric acid which are .....

- |                         |                                 |
|-------------------------|---------------------------------|
| (a) tranquilizers       | (b) non-narcotic analgesic      |
| (c) anti-allergic drugs | (d) neurologically active drugs |

**Ans. (a, d)**

Derivatives of barbituric acid viz., veronal and luminal are called barbiturates. These barbiturates constitute an important class of tranquilizers.

Tranquilizers are a class of chemical compounds used for the treatment of stress and mild or severe mental diseases. Tranquilizers are neurologically active drugs. These drugs affect the message transfer mechanism from nerve to receptor.

**Q. 29** Which of the following are anionic detergents?

- |   |
|---|
| (a) Sodium salts of sulphonated long chain alcohol      |
| (b) Ester of stearic acid and polyethylene glycol       |
| (c) Quarternary ammonium salt of amine with acetate ion |
| (d) Sodium salts of sulphonated long chain hydrocarbons |

**Ans. (a, d)**

Detergents are cleansing agents which have all the properties of soap, but which actually do not contain any soap. They are of three types which given below

1. **Anionic detergents** These are sodium salts of sulphonated long chain alcohols or hydrocarbons.

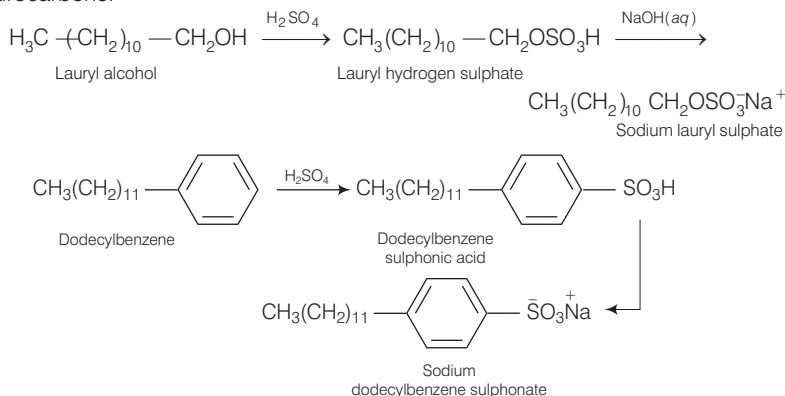

2. **Cationic detergents** These are quarternary ammonium salts of amines with acetates chlorides or bromides as anions e.g.,

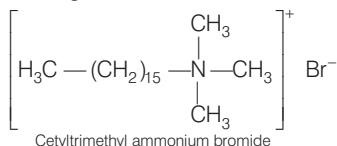

3. **Non-ionic detergents** It is formed by the reaction of stearic acid with polyethylene glycol.

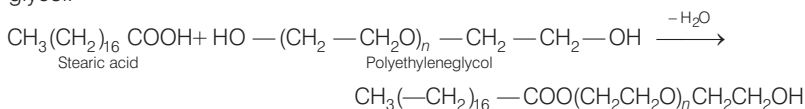

**Q. 30** Which of the following statements are correct?

- Cationic detergents have germicidal properties
- Bacteria can degrade the detergents containing highly branched chains
- Some synthetic detergents can give foam even in ice cold water
- Synthetic detergents are not soaps

**Ans. (a, c, d)**

- Cationic detergents are quarternary ammonium salts of amines with acetates, chlorides or bromides as anions. These detergents have germicidal properties. Hence, option (a) is correct.
- Bacteria can not degrade the detergents containing highly branched chains, therefore, in most of the detergents used these days, the branching is kept to a minimum so that the detergents become easily biodegradable. Hence, option (b) is incorrect.
- Some synthetic detergents can give foam even in ice cold water. Hence, option (c) is correct.
- Synthetic detergents are cleansing agents which have all the properties of soaps, but which actually do not contain any soap. Hence, option (d) is correct.



## Short Answer Type Questions

**Q. 31** What is the average molecular mass of drugs?

**Ans.** Drugs are the chemicals of low molecular masses *i.e.*, ( $\sim 100 - 500$  u). They interact with macromolecular targets and produce a biological response. When the biological response is therapeutic and useful, these chemicals are called medicines.

**Q. 32** Write the uses of medicines.

**Ans.** Chemical substances which are used in diagnosis, prevention and treatment of diseases which are called medicines.

Medicines are used in diagnosis, prevention and treatment of diseases.

**Note** *If drugs taken in doses higher than those recommended, most of the drugs used as medicines are potential poisons. Use of chemicals for therapeutic effect is called chemotherapy.*

**Q. 33** What are antiseptics?

**Ans.** Antiseptics are the antimicrobes. Antiseptics are the chemical which either kill or prevent the growth of microorganism and are safe to be applied to the living tissues *e.g.*, soframincine. They can not be taken orally like antibiotics.

**Q. 34** Which type of drugs come under antimicrobial drugs?

**Ans.** Disease in human beings and animals may be caused by a variety of microorganisms such as bacteria, virus, fungi and other pathogens.

An antimicrobial tends to destroy/prevent development or inhibit the pathogenic action of microbes such as bacteria (antibacterial drugs), fungi (antifungal agents), virus (antiviral agents), or other parasites (antiparasitic drugs) selectively. Antiseptic, disinfectants, antibiotics and sulpha drugs are antimicrobial drugs.

**Q. 35** Where are receptors located?

**Ans.** Receptors are proteins that are crucial to body's communication process. Receptors are embedded on the outer surface of the cell membrane in such a way that their small part possessing active site projects out of the surface of the membrane and opens on the outside region of the cell membrane.

**Q. 36** What is the harmful effect of hyperacidity?

**Ans.** Hyperacidity produces sudden stomach pain. It may lead to vomiting, loss of appetite, flatulence and heart burn. It is also responsible for chronic indigestion and in severe cases cause gastric ulcers.

**Q. 37** Which site of an enzyme is called allosteric site?

**Ans.** Sites different from active site of enzyme where a molecule can bind and change the shape of the active site is called allosteric site.

*(Also, refer to Q.16)*



**Q. 43** What is a soft soap?

**Ans.** Chemical substances which concentrates at the surface of the solution or interfaces, from surface films, reduces surface tension of the solution and help in removing dirt and dust by emulsifying grease are called surfactants *i.e.*, soap and detergents.

Soaps are sodium or potassium salts of long chain fatty acids such as palmitic acid ( $C_{15}H_{31}COOH$ ), stearic acid ( $C_{17}H_{35}COOH$ ) and linolic acid ( $C_{17}H_{31}COOH$ )

Potassium salts of fatty acids such as palmitic acid, stearic acid and oleic acid are called soft soap.

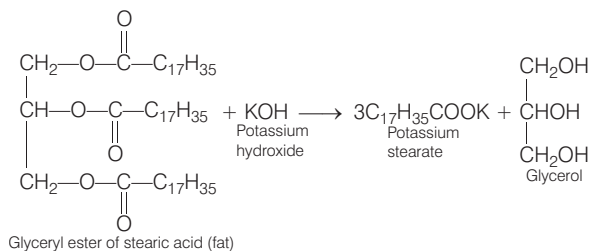

Generally, potassium soap are soft to the skin so, they are named as soft soap.

**Q. 44** If soap has high alkali content it irritates skin. How can the amount of excess alkali be determined? What can be the source of excess alkali?

**Ans.** A solution of soap is titrated with standard hydrochloric acid. It is an acid-base titration. In this titration, phenolphthalein is used as an indicator. During the preparation of soap, fat (*i.e.*, glyceryl ester of fatty acid) is heated with aqueous sodium hydroxide

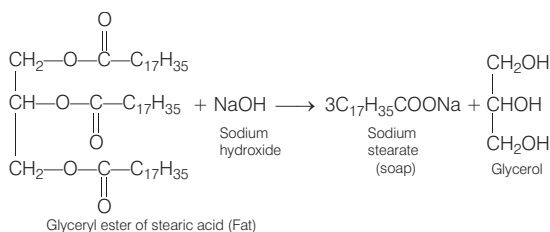

Thus, the source of this excess alkali (which irritates skin) is the alkali left unused when the soap is prepared by hydrolysis of fat.

**Q. 45** Explain why some times foaming is seen in river water near the place where sewage water is poured after treatment?

**Ans.** Detergents have long hydrocarbon chains. If their hydrocarbon chain is highly branched, then bacteria cannot degrade this easily. Such detergents are non-biodegradable. Slow degradation of detergents leads to their accumulation.

These non-biodegradable detergents persist in water even after sewage treatment and cause foaming in rivers, ponds and their water get polluted. In order to overcome this issue branching of the hydrocarbon chain is controlled and kept to minimum.

**Q. 46** Which category of the synthetic detergents is used in toothpaste?

**Ans.** Anionic detergents such as sodium lauryl sulphate, sodium dodecylbenzenesulphonate etc are used in toothpaste. They are responsible to clean the teeth and to provide a foam that helps to carry away the debris.

Further, sodium lauryl sulphates have significant antibacterial properties, and can penetrate as well as dissolve the plaque.

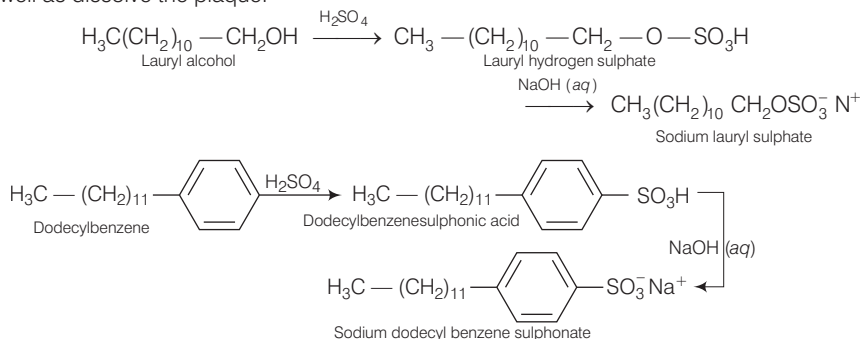

**Q. 47** Hair shampoos belong to which class of synthetic detergent?

**Ans.** Hair shampoos are made up of cationic detergents. These are quarternary ammonium salts of amines with acetates, chlorides or bromides as anions, e.g., cetyltrimethyl ammonium bromide.

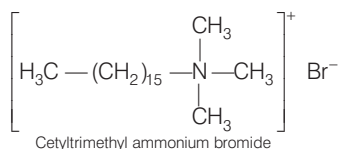

**Q. 48** Dishwashing soaps are synthetic detergents. What is their chemical nature?

**Ans.** Dishwashing soaps are non-ionic detergents. It can be prepared by the reaction of stearic acid with polyethylene glycol.

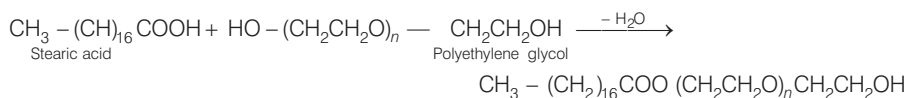

Since, non-ionic detergents do not contain any ion in their constitution, it is neutral in nature.

**Q. 49** Draw the diagram showing micelle formation by the following detergent.  
 $\text{CH}_3(\text{CH}_2)_{10}\text{CH}_2\text{OSO}_3^- \text{Na}^+$

**Ans.** Sodium lauryl sulphate,  $\text{CH}_3(\text{CH}_2)_{10}\text{CH}_2\text{OSO}_3^- \text{Na}^+$  is an example of anionic detergent. When added to water, it dissociates as follows

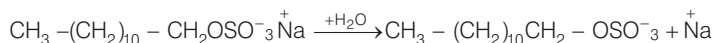

These anions are present on the surface with their  $-\text{OSO}_3^-$  groups in water and hydrocarbon part staying away from it and remain at the surface.

At higher concentration, these anions are pulled into the bulk of the solution and form an aggregate of spherical shape with their hydrocarbon part pointing towards the centre and  $\text{OSO}_3^-$  part outwards on the surface of the sphere.

An aggregate thus formed is known as micelle.

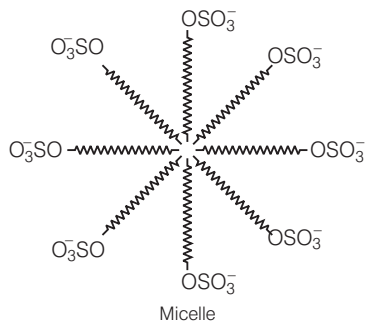

**Q. 50** How does the branching of hydrocarbon chain of synthetic detergents affect their biodegradability?

**Ans.** Detergents having highly branched hydrocarbon chains cause pollution in rivers. The reason being that side chains stop bacteria from attacking and breaking the chains.

Thus, lesser the branching more is the biodegradability *i.e.*, detergents with long straight hydrocarbon chains are more easily degraded than those having branched hydrocarbon chains.

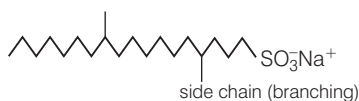

Since, unbranched (*i.e.*, straight) chains are more prone to attack by bacteria, therefore, in most of the detergents used these days, the branching is kept to be minimum, so that the detergents become easily biodegradable.

**Q. 51** Why is it safer to use soap from the environmental point of view?

**Ans.** Soaps are biodegradable while detergents containing branched hydrocarbon chains are quite stable, *i.e.*, they are not degraded by the action of microorganism and therefore it cause water pollution in rivers and other water ways.

**Q. 52** What are analgesics?

**Ans.** Analgesics reduce or abolish pain without causing impairment of consciousness, mental confusion, incoordination or paralysis or some other disturbances of nervous system.

*These are classified in two groups*

- (i) **Non-narcotic analgesics** These are non-addictive analgesics *e.g.*, aspirin.
- (ii) **Narcotic analgesics** Morphine is an example of narcotic analgesics.

**Q. 53** What is the scientific explanation for the feeling of depression ?

**Ans.** Noradrenaline is a neuro-transmitter which plays an crucial role in mood changes. If any person has low level of noradrenaline, then the message transfer process becomes slow and the person feeling of depression.

**Q. 54** What is the basic difference between antiseptics and disinfectants ?

**Ans.** Antiseptics and disinfectants both are antimicrobials. Antiseptics prevent or destroy development or inhibit the pathogenic action of microbes. They are safe to be applied on living tissues.

On the other hand, disinfectants also kill microorganisms but are not safe to be applied on living tissues. They are generally applied on non-living objects such as drains, toilets, floors and living rooms infected with bacteria and disease carrying germs.

**Q. 55** Between sodiumhydrogencarbonate and magnesium hydroxide which is a better antacid and why ?

**Ans.** Magnesium hydroxide  $[\text{Mg}(\text{OH})_2]$  is a better antacid because being insoluble it does not allow the pH to increase above neutrality. On the other hand, sodium hydrogen carbonate being soluble and its excess amount can make the stomach alkaline and trigger the production of even more acid.

**Q. 56** Which analgesics are called opiates ?

**Ans.** Analgesics reduce or abolish pain without causing impairment of consciousness, mental confusion, incoordination or paralysis or some other disturbances of nervous system. *These are classified in two categories*

- (i) **Non-narcotic** (non-addictive) **analgesics** - Aspirin and paracetamol belong to the class of non-narcotic analgesics.
- (ii) **Narcotic analgesics**—Morphine and many of its homologues, when administered in medicinal doses, relieve pain and produce sleep. In poisonous doses, these produce stupor, coma, convulsions and ultimately death. Morphine narcotics are sometimes referred to as opiates, since they are obtained from the opium poppy.

**Q. 57** What is the medicinal use of narcotic drugs ?

**Ans.** Narcotic analgesics (morphine and many of its homologous) when administered in medicinal doses, relieve pain and produce sleep. Since, these drugs relieve pain and produce sleep, therefore are chiefly used for the relief of postoperative pain, cardiac pain and pains of terminal cancer, and in child birth.

**Q. 58** What are antagonistic drugs ?

**Ans.** Drugs that bind to the receptor site and inhibit its natural function are called antagonist, drugs e.g., cimetidine is an antagonist drug because it binds to the receptor site in stomach otherwise histamine will bind to the receptor site and induce the secretion of HCl in stomach.

Thus, this antacid blocks the receptor site and hence, the secretion of HCl is reduced thereby reducing/removing hyperacidity.

**Q. 59** What is the mode of action of antimicrobial drugs?

**Ans.** Antimicrobes tend to destroy/prevent development or inhibit the pathogenic action of microbes such as bacteria, fungi, virus or other parasites selectively. Thus, antimicrobial are drugs which cure diseases caused by microorganisms.

**Q. 60** What is the side product of soap industry ? Give reactions showing soap formation.

**Ans.** Soaps are sodium or potassium salts of long chain fatty acids such as stearic acid, oleic acid and palmitic acid. Soaps containing sodium salts are formed by heating fat (*i.e.*, glyceryl ester of fatty acid) with aqueous sodium hydroxide.

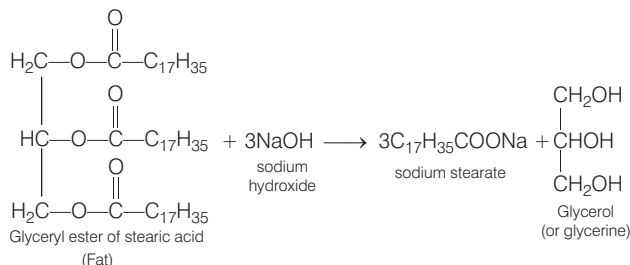

This reaction is known as saponification. In this reaction, esters of fatty acids are hydrolysed and the soap obtained remains in colloidal form. It is precipitated from the solution by adding NaCl. The solution left after removing the soap contains glycerol as side product.

**Q. 61** What is the difference between bathing soap and washing soaps?

**Ans.** Bathing soaps are potassium salts of long chain fatty acids. They are usually soft and are also free from unused alkali. On the other hand, washing soaps are sodium salts of long chain fatty acids. They are usually hard and also contain some residual alkali.

**Q. 62** How are transparent soaps manufactured?

**Ans.** Soap that float in water are made by beating tiny air bubbles before their hardening. Transparent soaps are made by dissolving the soap in ethanol and then evaporating the excess solvent.

**Q.63** What is the advantage of using antihistamines over antacids in the treatment of acidity?

**Ans.** Usual antacid like sodium hydrogen carbonate control only the symptom and not the cause. They neutralize the excess of acid produce in the stomach. but do not control the cause of production of excess of HCl in stomach.

Histamine, a chemical, is responsible for the secretion of pepsin and HCl in the stomach. Antihistamine are the drugs which suppress the action of histamine, which in turn suppress the secretion of pepsin and HCl in the stomach. Antihistamine prevent the binding of histamine with the receptors present in the stomach wall.

As a result, less HCl is produced and hyperacidity is cured. Thus, a better treatment for curing acidity is to use antihistamines over antacids.

**Q.64** What are the functions performed by histamine in the body?

**Ans.** Histamine is a potent vasodilator. It performs various functions in the body

- (i) It contracts muscles in gut and bronchi.
- (ii) It relaxes some other muscles, *e.g.*, in the walls of blood vessels.
- (iii) It is responsible for congestion in the nose associated with common cold and allergies.
- (iv) It stimulates the release of pepsin and HCl in stomach.

**Q. 65** With the help of an example explain how do tranquilizers control the feeling of depression?

**Ans.** Noradrenaline is a neurotransmitter which plays a crucial role in mood changes. If somehow any person has low level of noradrenaline in the body, then the signal sending activity becomes slow and the person suffers from depression.

For removing depression and to boost the mood, tranquilizers are used. These drugs inhibit the enzyme which catalyse the degradation of noradrenaline.

From this result, neurotransmitter noradrenaline is slowly metabolised and can thus activate the receptor for longer periods.

**Q. 66** Why are certain drugs called enzyme inhibitors?

**Ans.** Some drugs can block the binding site of the enzyme and prevent the binding of the substrate, or can inhibit the catalytic activity of the enzyme. Such drugs are called enzyme inhibitors.

(Also, refer to Q. 16.)

**Q. 67** What are fillers and what role these fillers play in soap?

**Ans.** Substances which are added to soaps to change their properties in order to make them more useful for a particular application, are called fillers. *Some important examples are given below*

- (i) Sodium rosinate, sodium silicate, borax and sodium carbonate are added to laundry soaps to increase their lather forming ability.
- (ii) Glycerol is added to shaving soaps to prevent them from rapid drying.
- (iii) In medicated soaps, substances of medicinal values are added.

**Q. 68** Sugar is the main source of energy as it produces energy on metabolic decomposition. But these days low calorie drinks are more popular, why?

**Ans.** Natural sweeteners *e.g.*, sucrose add to calorie intake. Due to occurrence of more cases of diabetes and obesity among young and old people, these days people usually take low calorie drinks. *These are artificial sweetening agents as given below*

**Saccharin** It is 550 times as sweet as cane sugar. It is excreted from the body through urine.

**Aspartame** It is 100 times as sweet as cane sugar. Its use is limited to cold foods and soft drinks because it is unstable at cooking temperature.

**Alitame** It is more stable than aspartame but the control of sweeteners of food is difficult while using it.

**Sucralose** It is stable at cooking temperature. It does not provide calories.

These artificial sweetening agents do not metabolize and hence do not produce any energy.

**Q. 69** Pickles have a long shelf life and do not get spoiled for months, why?

**Ans.** Plenty of salt and cover of oil act as preservatives. These food preservatives prevent spoilage of food due to microbial growth. Salt and oil do not allow moisture and air to enter the material and hence bacteria cannot thrive on them. Therefore, pickles do not get spoiled for months together.



**Q. 70** What is the difference between saccharin and saccharic acid?

**Ans.** Saccharin is an artificial sweetening agent. It is about 550 times as sweet as cane sugar. It is excreted from the body in urine unchanged. It appears to be entirely inert and harmless when taken. Its use is of great value to diabetic people who need to control intake of calories.

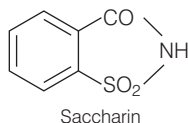

On the other hand, saccharic acid, is a dibasic acid obtained by the bacterial oxidation of glucose in the mouth or by conc.  $\text{HNO}_3$  in the laboratory.

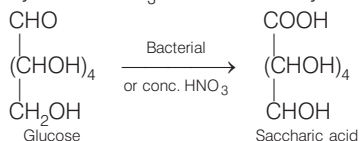

**Q. 71** Name an artificial sweetener which is derivative of sucrose.

**Ans.** **Sucralose** is trichloro derivative of the sucrose. Its appearance and taste are like sugar. It is stable at cooking temperature. Sucralose contributes zero calories to the diet, compared with sucrose, which contributes 16 calories per teaspoon. Structure of sucralose is

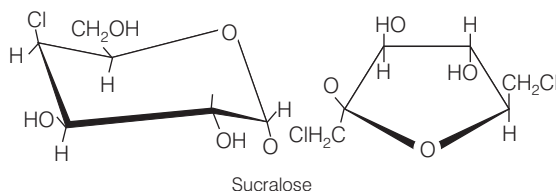

**Q. 72** Name two  $\alpha$ -amino acids which form a dipeptide which is 100 times more sweet than cane sugar ?

**Ans.** Aspartame is the most successful and widely used artificial sweetener. It is methyl ester of dipeptide formed from aspartic acid and phenylalanine. Its use is limited to cold foods and soft drinks because it is unstable at cooking temperature.

Structure of aspartame is

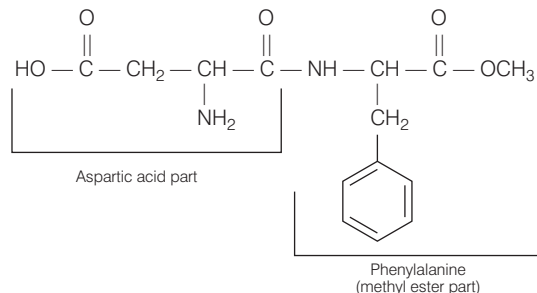

**Q. 73** Aspartame is unstable at cooking temperature, where would you suggest aspartame to be used for sweetening?

**Ans.** Aspartame is used in cold foods and soft drinks. It is an artificial sweetening agent.  
(Also, refer to Q. 72)

**Q. 74** Sodium salts of some acids are very useful as food preservatives. Suggest a few such acids.

**Ans.** A preservative is naturally occurring or synthetically produced substance that is added to foods to prevent decomposition by microbial growth or by undesirable chemical changes. Sodium salts of some acids are very useful as food preservatives. *Some examples of such acids are as follows*

- (i) Benzoic acid in the form of its sodium salt, constitutes one of the most common food preservative. Sodium benzoate is a common preservative in acid or acidified foods such as fruit, juices, pickles etc. Yeasts are inhibited by benzoate to a greater extent than are moulds and bacteria.
- (ii) Sorbic acid and its salts (sodium, potassium and calcium) also have preservative activities but the applications of sodium sorbate  $C_6H_7NaO_2$  are limited compared to that for potassium salt.
- (iii) Sodium erythorbate  $C_6H_7NaO_6$  is a food additive used predominate in meats, poultry and soft drinks.
- (iv) Sodium propanoate  $Na(C_2H_5COO)$  is used in bakery products as mold inhibitor.

**Q. 75** Explain the role of allosteric site in enzyme inhibition?

**Ans.** Some drugs do not bind to the active site of enzymes to inhibit their activities. These bind to a different site of enzyme. This binding of inhibitor (drug) changes the shape of the active site in such a way that substrate cannot recognise it.

The site different from active site of an enzyme where a drug molecule can bind is called the allosteric site.

Non-competitive inhibitor changes the active site of enzyme after binding at allosteric site.

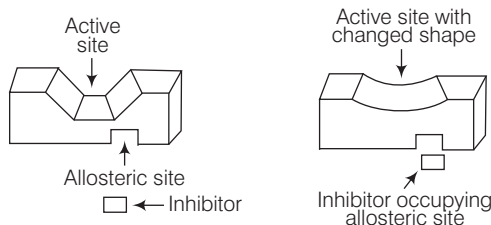

**Non-competitive inhibitor changes the active site of enzyme after binding at allosteric site**

**Q. 76** How are receptor proteins located in the cell membrane?

**Ans.** Receptor proteins are embedded in the cell membrane in such a way that their small part possessing active site projects out of the surface of the it membrane and opens on the outside region of the cell membrane.

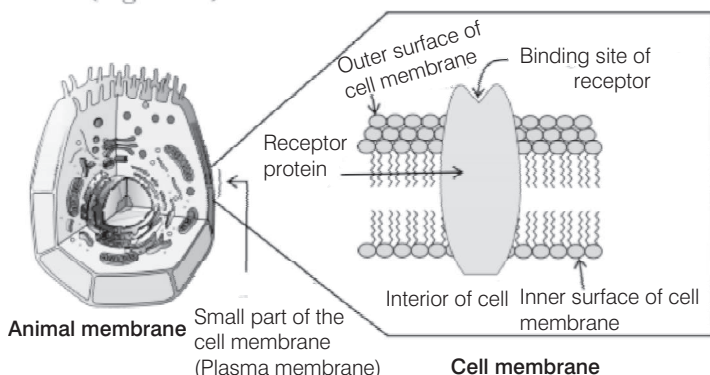

**Receptor protein embedded in the cell membrane, the active site of the receptor opens on the outside region of the cell**

**Q.77** What happens when the bond formed between an enzyme and an inhibitor is a strong covalent bond?

**Ans.** Generally, a weak bond such as H-bonding, van der Waals' interactions, etc., is formed between the enzyme and inhibitor. If a strong covalent bond is formed between the enzyme and the inhibitor which cannot be broken easily, then the enzyme is blocked permanently. The body then degrades the enzyme-inhibitor complex and synthesises the new enzyme.

## Matching The Columns

**Q. 78** Match the medicines given in Column I with their uses given in Column II.

Column I	Column II
A. Ranitidine	1. Tranquilizer
B. Furacine	2. Antibiotic
C. Phenelzine	3. Antihistamine
D. Chloramphenicol	4. Antiseptic
	5. Antifertility drug

**Ans. A.** → (3)    **B.** → (4)    **C.** → (1)    **D.** → (2)

- A. **Ranitidine** It prevents the interaction of histamine with the receptors present in the stomach wall. Thus, it controls the secretion of HCl and pepsin in stomach.
- B. **Furacine** Furacine is an antiseptic. It can be applied to the living tissues to kill or to prevent the growth of microorganisms.
- C. **Phenelzine** It is also known as Nardil. Its structure is

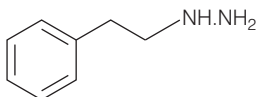

It is used to treat depression.

- D. **Chloramphenicol** It is a broad spectrum antibiotic. It can be given orally in case of typhoid, acute fever, dysentery, certain urinary infections, meningitis and pneumonia.

**Q. 79** Match the soaps given in Column I with items given in column II.

Column I	Column II
A. Soap chips	1. dried miniature soap bubbles
B. Soap granules	2. small broken pieces of soap formed from melted soaps
C. Soap powder	3. soap powder + abrasives + builders (Na <sub>2</sub> CO <sub>3</sub> , Na <sub>3</sub> PO <sub>4</sub> )
D. Scouring soap	4. soap powder + builders like Na <sub>2</sub> CO <sub>3</sub> and Na <sub>3</sub> PO <sub>4</sub>

**Ans. A.** → (2)    **B.** → (1)    **C.** → (4)    **D.** → (3)

- A. Soap chips are made by running a thin sheet of melted soap into a cool cylinder and scraping off the soaps in small broken pieces.
- B. Soap granules are dried miniature soap bubbles.
- C. Soap powders contain soap powder and builders like sodium carbonate and trisodium phosphate. Builders make the soap act more rapidly.
- D. Scouring soaps contain soap powder, a scouring agent (abrasive) such as powdered pumice or finely divided sand and builders.

**Q. 80** Match structures given in Column I with the type of detergents given in Column II.

Column I	Column II
A. CH <sub>3</sub> (CH <sub>2</sub> ) <sub>16</sub> COO(CH <sub>2</sub> CH <sub>2</sub> O) <sub>n</sub> , CH <sub>2</sub> CH <sub>2</sub> OH	1. Cationic detergent
B. C <sub>17</sub> H <sub>35</sub> COO <sup>-</sup> Na <sup>+</sup>	2. Anionic detergent
C. CH <sub>3</sub> —(CH <sub>2</sub> ) <sub>10</sub> CH <sub>2</sub> SO <sub>3</sub> <sup>-</sup> Na <sup>+</sup>	3. Nonionic detergent
D. $\left[ \text{CH}_3(\text{CH}_2)_{15} - \underset{\text{CH}_3}{\overset{\text{CH}_3}{\text{N}}} - \text{CH}_3 \right]^+ \text{Br}^-$	4. Soap



**Q. 82** Match the class of compounds given in Column I with their functions given in Column II.

Column I	Column II
A. Antagonists	1. Communicate message between two neurons and that between neurons to muscles.
B. Agonists	2. Bind to the receptor site and inhibit its natural function.
C. Chemical messenger	3. Crucial to body's communication process.
D. Inhibitors	4. Mimic the natural messenger.
E. Receptors	5. Inhibit activities of enzymes.

**Ans.** A. → (2)    B. → (4)    C. → (1)    D. → (5)    E. → (3)

- A. **Antagonist** drugs are used when blocking of message is required. e.g., dopamine antagonist is a drug which blocks the dopamine receptors by receptor antagonism.
- B. **Agonist** drugs are useful when there is lack of chemical messenger. e.g., heroin.
- C. These **chemical messengers** are received at the binding sites of receptor. These communicate message between two neurons and that between neurons to muscles.
- D. **Inhibitors** block the binding site of the enzyme and prevent the binding of the substrate, or inhibit the catalytic activity of the enzyme.
- E. **Receptors** are proteins that are crucial to body's communication. They are embedded in the cell membrane in such a way that their small part possessing active site projects out of the surface of the membrane and opens on the outside region of the cell membrane.

**Q. 83** Match the classes of drugs given in Column I with their action given in Column II.

Column I	Column II
A. Analgesics	1. Inhibit the growth of microorganisms can be given orally
B. Antiseptics	2. Treatment of stress
C. Antihistamines	3. Applied to inanimate objects
D. Antacids	4. Prevents the interaction of histamine with its receptor
E. Tranquilizers	5. Pain killing effect
F. Antibiotics	6. Applied to diseased skin surfaces
G. Disinfectants	7. Treatment of acidity

**Ans.** A. → (5)    B. → (6)    C. → (4)    D. → (7)    E. → (2)    F. → (1)    G. → (3)

- A. **Analgesics** reduce or abolish pain without causing impairment of consciousness, mental confusion, in coordination or paralysis or some other disturbances of nervous system, e.g., aspirin.
- B. **Antiseptics** are the chemicals which either kill or prevent the growth of microorganisms. They are applied to living tissues such as wounds, cuts etc., e.g., tincture of iodine.
- C. **Antihistamines** are anti-allergic drugs. These drugs interfere with the natural action of histamine by competing with histamine for binding sites of receptor where histamine exerts its effect. e.g., seldane.

- D. **Antacids** are used to neutralise excess of acid released in stomach e.g., mixture of  $\text{Mg}(\text{OH})_2$  and  $\text{Al}(\text{OH})_3$ .
- E. **Tranquilizers** are used for the treatment of stress, and mild or even severe mental diseases e.g., equanil.
- F. **Antibiotics** are antimicrobial drugs. Antibiotics are used as drugs to treat infections because of their low toxicity for humans and animals e.g., chloramphenicol.
- G. **Disinfectants** are the chemicals which either kill or prevent the growth of microorganisms but they can be applied on non-living objects e.g., 1 per cent solution of phenol.

## Assertion and Reason

*In the following questions a statement of assertion (A) followed by a statement of reason (R) is given. Choose the correct answer out of the following choices.*

- (a) Assertion and reason both are correct statements but reason does not explain assertion.
- (b) Assertion and reason both are correct and reason explains the assertion.
- (c) Both assertion and reason are wrong statements.
- (d) Assertion is correct statement reason is wrong statement.
- (e) Assertion is wrong statement reason is correct statement.

**Q. 84 Assertion (A)** Penicillin (G) is an antihistamine.

**Reason (R)** Penicillin (G) is effective against gram positive as well as gram negative bacteria.

**Ans. (c)** Both assertion and reason are wrong statements. **Correct assertion** Penicillin (G) is an antibiotic.

**Correct reason** Penicillin is effective against some gram positive bacteria.

**Q. 85 Assertion (A)** Sulpha drug contain sulphonamide group.

**Reason (R)** Salvarsan is a sulpha drug.

**Ans. (d)** Asssertion is correct statement reason is wrong statement. **Correct reason** Salvarsan is a antibacterial but does not contain sulphonamide group.

**Q. 86 Assertion (A)** Receptors are crucial to body's communication process.

**Reason (R)** Receptors are proteins.

**Ans. (a)** Assertion and reason both are correct statements but reason does not explain assertion. **Correct Explanation** Neurotransmitters are small molecules which bind to the receptor for a very short time to transfer message to it and depart quickly unchanged after transferring the message. The receptor then forwards the message inside the cell.

**Q. 87 Assertion** (A) Enzymes have active sites that hold substrate molecule for a chemical reaction.

**Reason** (R) Drugs compete with natural substrate by attaching covalently to the active site of enzyme.

**Ans. (d)** Assertion is correct statement reason is wrong statement **Correct reason** Drug compete with natural substrate by attaching by weak bonds such as hydrogen bond, van der Waals', interaction and ionic bonding etc., to the active site of the enzyme.

**Q. 88 Assertion** (A) Chemical messengers are chemicals that enable communication of message between two neurons or between neurons and muscles.

**Reason** (R) Chemicals enter the cell through receptor.

**Ans. (d)** Assertion is correct statement reason is wrong statement. **Correct reason** Chemicals bind to the receptor sites present on the surface of the membrane or the cell. They give message to the cell without entering the cell.

**Q. 89 Assertion** (A) Transparent soaps are made by dissolving soaps in ethanol.

**Reason** (R) Ethanol makes things invisible.

**Ans. (d)** Assertion is correct statement reason is wrong statement. **Correct reason** Ethanol removes air and moisture which scatter light.

**Q. 90 Assertion** (A) Sodium chloride is added to precipitate soap after saponification.

**Reason** (R) Hydrolysis of esters of long chain fatty acids by alkali produces soap in colloidal form.

**Ans. (b)** Assertion and reason both are correct and reason explains the assertion. Sodium chloride is added to precipitate soap after saponification because hydrolysis of esters of long chain fatty acids by alkali produces soap in colloidal form.

**Q. 91 Assertion** (A) Competitive inhibitors compete with natural substrate for their attachment on the active sites of enzymes.

**Reason** (R) In competitive inhibition, inhibitor binds to the allosteric site of the enzyme.

**Ans. (d)** Assertion is correct statement reason is wrong statement. **Correct reason** In competitive inhibition, inhibitor binds to the active site of the enzyme.

**Q. 92 Assertion** (A) Non-competitive inhibitor inhibits the catalytic activity of enzyme by binding with its active site.

**Reason** (R) Non-competitive inhibitor changes the shape of the active site in such a way that substrate can't recognise it.

**Ans. (e)** Assertion is wrong statement reason is correct statement. **Correct assertion** Non-competitive inhibitor inhibits the catalytic activity by binding the enzyme at allosteric site.



**Q. 93 Assertion** (A) Chemical messenger gives message to the cell without entering the cell.

**Reason** (R) Chemical messenger is received at the binding site of receptor proteins.

**Ans. (b)** Assertion and reason both are correct and reason explains the assertion. Chemical messenger gives message to the cell without entering the cell because it is received at the binding site of receptor proteins.

**Q. 94 Assertion** (A) Receptor proteins show selectivity for one chemical messenger over the other.

**Reason** (R) Chemical messenger binds to the receptor site and inhibits its natural function.

**Ans. (d)** Assertion is correct statement reason is wrong statement. **Correct reason** Chemical messenger binds the receptor site and gives the message to the cell without entering the cell.

**Q. 95 Assertion** (A) All chemicals added to food items are called food preservatives.

**Reason** (R) All these chemicals increase the nutritive value of the food.

**Ans. (c)** Both assertion and reason are wrong statements. **Correct assertion** Chemicals which are used to protect food against bacteria, yeasts and moulds are called food preservatives.

**Correct reason** Preservatives do not increase the nutritive values of food.

**Q. 96 Assertion** (A) Preservative are added to food items.

**Reason** (R) Preservatives inhibit the growth of microorganisms.

**Ans. (b)** Assertion and reason both are correct and reason explains the assertion. Preservatives are added to food items because it inhibit the growth of microorganisms.

**Q. 97 Assertion** (A) Artificial sweeteners are added to the food to control the intake of calories.

**Reason** (R) Most of the artificial sweeteners are inert and do not metabolise in the body.

**Ans. (b)** Assertion and reason both are correct and reason explains the assertion. Artificial sweeteners are added to the food to control the intake of calories because most of the artificial sweeteners are inert and do not metabolise in the body.

## Long Answer Type Questions

**Q. 98** In what respect do prontosil and salvarsan resemble. Is there any resemblance between azo dye and prontosil? Explain.

**Ans.** Prontosil, also called sulfamido chrysoidine, trade name of the first synthetic drug used in the treatment of general bacterial infections in humans.

Prontosil resulted from research, directed by German chemist and pathologist Gerhard Domagk, on the antibacterial action of azo dyes. A red azo dye of low toxicity, prontosil was shown by Domagk to prevent mortality in mice infected with *Streptococcus* bacteria.

The dye was also effective in controlling staphylococcus infections in rabbits. Within a relatively short period, it was demonstrated that prontosil was effective not only in combating experimental infections in animals but also against Streptococcal disease in humans, including meningitis and puerperal sepsis. Structural formula of prontosil is

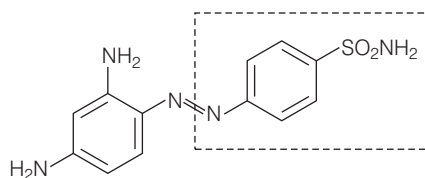

Prontosil

From the structure of prontosil, it is very clear that it has  $\text{—N}=\text{N—}$  linkage. It was discovered that the part of the structure of prontosil molecule shown in box, i.e., p-aminobenzenesulphonamide has antibacterial activity.

Salvarsan is also known as arsphenamine. It was introduced at the beginning of 1910s as the first effective treatment for syphilis. It is an organoarsenic molecule and has  $\text{—As}=\text{As—}$  double bond.

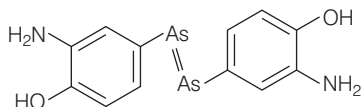

Salvarsan

Salvarsan and prontosil show similarity in their structure. Both of these drugs are antimicrobials. Salvarsan contains  $\text{—As}=\text{As—}$  linkage whereas prontosil has  $\text{—N}=\text{N—}$  linkage.

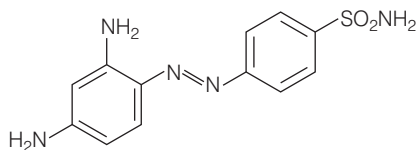

Prontosil

Prontosil (a red azo dye) and azo dye both have  $\text{—N}=\text{N—}$  linkage.

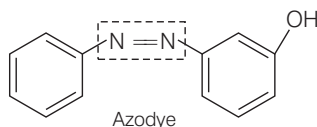

Azodye

**Q. 99** How do enzymes catalyse a chemical reaction in the living system? Explain drug target interaction taking the example of enzyme as target.

**Ans.** In the catalytic activity, enzymes perform the following two major functions

- (i) The first function of an enzyme is to hold the substrate molecule for a chemical reaction. The active sites of the enzymes hold the substrate molecule in a suitable position, so that it can be attacked by the reagent effectively.

The substrate molecules bind to the amino acid residues of the protein present in the active site of the enzyme through a variety of interactions such as hydrogen bonding, dipole-dipole interactions, van der Waals' interactions and ionic bonding.

These binding forces should be strong enough to hold the substrate long enough so that the enzyme can catalyse the reaction, but weak enough to allow the products to depart after their formation.



- (ii) The second function of the enzyme is to provide functional groups which will attack the substrate to carry out the chemical reaction. This function is carried out by some other amino acid residues of protein present on the active site of the enzyme.

These provide free amino groups to attack the substrate and bring about the chemical reaction. If the amino acid serine is present nearby the substrate held on the active site, then its  $-OH$  group is free to act as a nucleophile in the enzyme catalysed reaction.

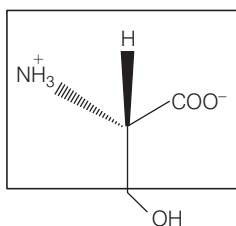

L-serine

The part of the amino acid which lies outside the box acts as a nucleophile in enzyme catalysed reactions, but the part of the amino acid which is enclosed in the box is involved in the formation of peptide bond in protein molecule.

**Q. 100** Synthetic detergents have advantage over usual soaps as far as cleansing power is concerned. But use of synthetic detergents over a long time creates environmental pollution. How can the pollution caused by synthetic detergents be minimised? Classify the detergents according to their chemical nature.

**Ans.** Synthetic detergents are cleansing agents which have all the properties of soaps, but which actually do not contain any soap. These can be used in soft as well as in hard water.

They are mainly classified into three categories

### (1) Anionic Detergents

Anionic detergents are sodium salts of sulphonated long chain alcohols or hydrocarbons. Alkyl hydrogen sulphates formed by treating long chain alcohols with conc.  $\text{H}_2\text{SO}_4$  are neutralised with alkali to form anionic detergents. Similarly alkyl benzene sulphonates are obtained by neutralising alkyl benzene sulphononic acids with alkali.

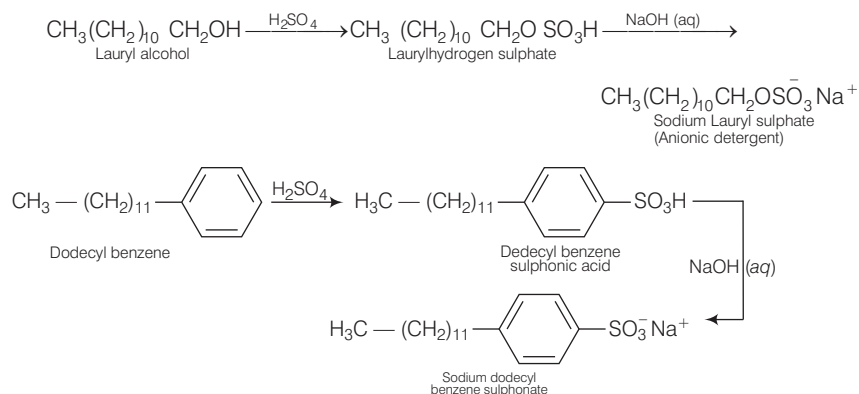

In these detergents, the anionic part of the molecule is involved in the cleansing action. They are mostly used for house hold work. They are also used in toothpaste.

### (2) Cationic Detergents

They are quarternary ammonium salts of amines with acetates, chlorides or bromides as anions. Cationic part possess a long hydrocarbon chain and a positive charge on nitrogen atom. Cetyltrimethylammonium bromide is a popular cationic detergent and is used in hair conditioners.

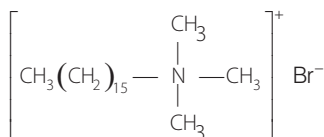

Cationic detergents have germicidal properties and are expensive, therefore, these are of limited use.

### (3) Non-ionic Detergents

Non-ionic detergents do not contain any ion in their constitution. One such detergent is formed when stearic acid reacts with polyethylene glycol.

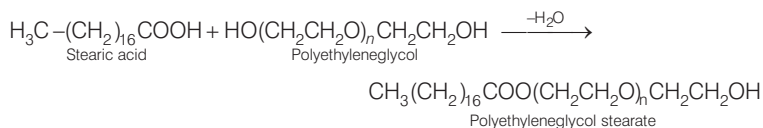

Liquid dishwashing detergents are non-ionic type

Advantages of Synthetic Detergents over Soaps

- Synthetic detergents can be used in hard water without any wastage while some of the soaps gets wasted.
- Synthetic detergents can be used in acidic medium while soaps get precipitated.
- Synthetic detergents are more soluble in water and hence produce lather more easily than soaps. Some synthetic detergents produce lather even in ice cold water.
- Synthetic detergents decrease the surface tension of water to greater extent and hence have a stronger cleansing action than soap.

Synthetic detergents have advantages over usual soaps but use of synthetic detergents over a long time creates environmental pollution because some detergents have highly branched hydrocarbon chains.

These branches or side chains stop bacteria from attacking and breaking the chains. This results in slow degradation of detergent molecule leading to their accumulation. Effluents containing these detergents reach the rivers, ponds etc. These persist in water even after sewage treatment and thus water gets polluted.

Since, unbranched (*i.e.*, straight) chains are more prone to attack by bacteria, therefore, in most of the detergents used these days, the branching is kept to a minimum, so that the detergents become easily biodegradable and hence pollution is prevented.

**Q. 101** What are enzyme inhibitors? Classify them on the basis of their mode of attachments on the active site of enzymes. With the help of diagrams explain how do inhibitors inhibit the enzymatic activity.

**Ans.** Enzymes are responsible to hold the substrate molecule for a chemical reaction and they provide functional groups which will attack the substrate to carry out the chemical reaction. Drugs which inhibit any of the two activities of enzymes are called enzyme inhibitors.

Enzyme inhibitors can block the binding site thereby preventing the binding of the substrate to the active site and hence inhibiting the catalytic activity of the enzyme.

*Drugs inhibit the attachment of natural substrate on the active site of enzymes in two different ways as explained below*

(i) Drugs which compete with natural substrate for their attachment on the active sites of enzymes are called competitive inhibitors.

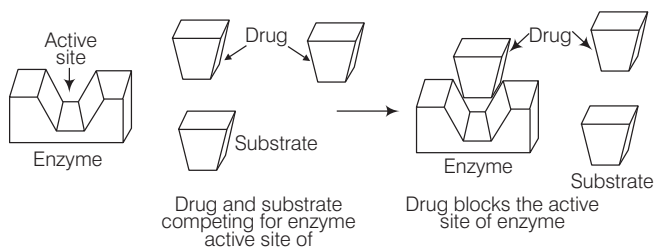

(ii) Some drugs, however, do not bind to the active site but bind to a different site of the enzyme which is called allosteric site. This binding of the drug at allosteric site changes the shape of the active site of the enzyme in such a way that the natural substrate cannot recognise it. Such enzymes are called non-competitive inhibitors.

